

VOL. 9, NO. 1

URAL MATHEMATICAL JOURNAL

N.N. Krasovskii Institute of Mathematics and Mechanics of
the Ural Branch of Russian Academy of Sciences and
Ural Federal University named after the first President of Russia B.N.Yeltsin

ISSN: 2414-3952

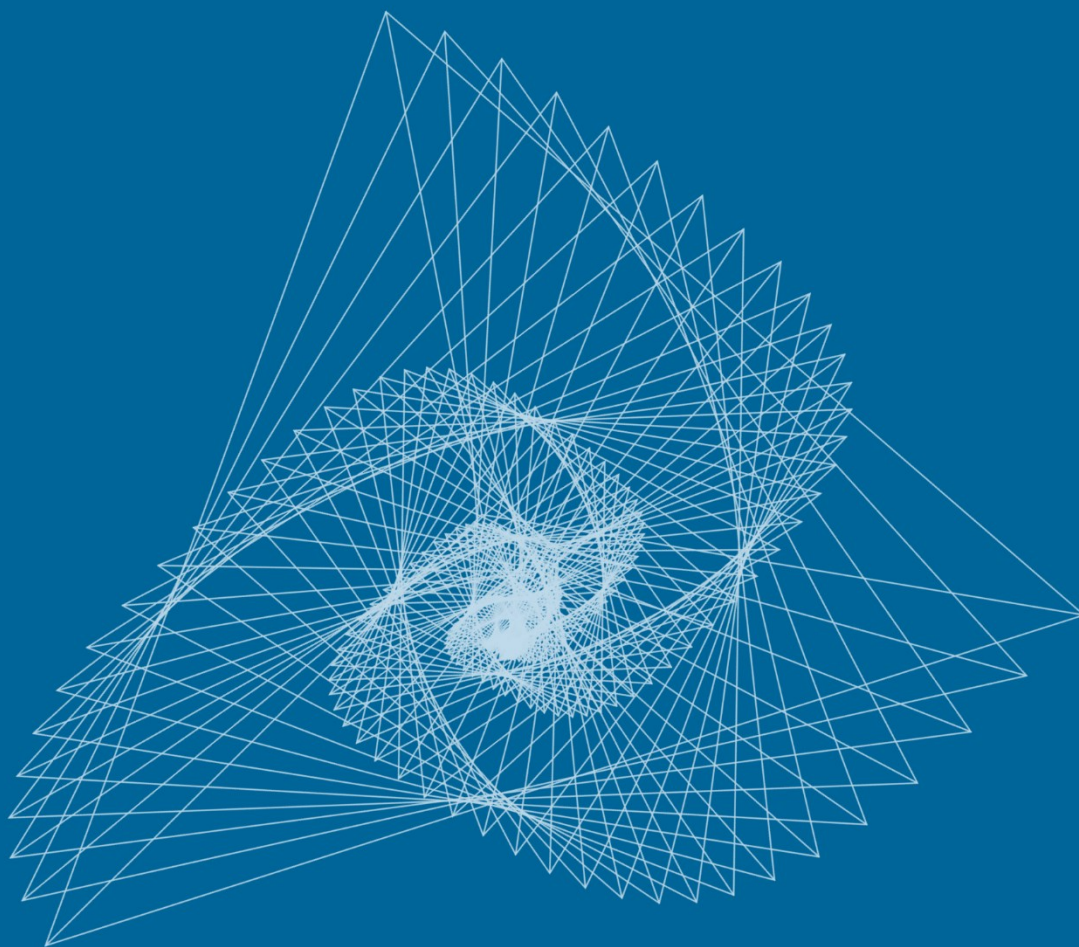



Electronic Periodical Scientific Journal
Founded in 2015

*The Journal is registered by the Federal Service for Supervision in the Sphere of
Communication, Information Technologies and Mass Communications
Certificate of Registration of the Mass Media Эп № ФЦ77-61719 of 07.05.2015*

Founders

N.N. Krasovskii Institute of Mathematics and Mechanics of the Ural
Branch of Russian Academy of Sciences
Ural Federal University named after the first President of Russia
B.N. Yeltsin

Contact Information

16 S. Kovalevskaya str., Ekaterinburg, Russia, 620990
Phone: +7 (343) 375-34-73 Fax: +7 (343) 374-25-81
Email: secretary@umjuran.ru
Web-site: <https://umjuran.ru>

EDITORIAL TEAM

EDITOR-IN-CHIEF

Vitalii I. Berdyshev, Academician of RAS, Krasovskii Institute of Mathematics and Mechanics, Ural Branch of the Russian Academy of Sciences, Ekaterinburg, Russia

DEPUTY CHIEF EDITORS

Vitalii V. Arestov, Ural Federal University, Ekaterinburg, Russia
Nikolai Yu. Antonov, Krasovskii Institute of Mathematics and Mechanics, Ural Branch of the Russian Academy of Sciences, Ekaterinburg, Russia
Vladislav V. Kabanov, Krasovskii Institute of Mathematics and Mechanics, Ural Branch of the Russian Academy of Sciences, Ekaterinburg, Russia

SCIENTIFIC EDITORS

Tatiana F. Filippova, Krasovskii Institute of Mathematics and Mechanics, Ural Branch of the Russian Academy of Sciences, Ekaterinburg, Russia
Vladimir G. Pimenov, Ural Federal University, Ekaterinburg, Russia

EDITORIAL COUNCIL

Alexander G. Chentsov, Krasovskii Institute of Mathematics and Mechanics, Ural Branch of the Russian Academy of Sciences, Ekaterinburg, Russia
Sergei V. Matveev, Chelyabinsk State University, Chelyabinsk, Russia
Alexander A. Makhnev, Krasovskii Institute of Mathematics and Mechanics, Ural Branch of the Russian Academy of Sciences, Ekaterinburg, Russia
Irina V. Melnikova, Ural Federal University, Ekaterinburg, Russia
Fernando Manuel Ferreira Lobo Pereira, Faculdade de Engenharia da Universidade do Porto, Porto, Portugal
Stefan W. Pickl, University of the Federal Armed Forces, Munich, Germany
Szilárd G. Révész, Alfréd Rényi Institute of Mathematics of the Hungarian Academy of Sciences, Budapest, Hungary
Lev B. Ryashko, Ural Federal University, Ekaterinburg, Russia
Arseny M. Shur, Ural Federal University, Ekaterinburg, Russia
Vladimir N. Ushakov, Krasovskii Institute of Mathematics and Mechanics, Ural Branch of the Russian Academy of Sciences, Ekaterinburg, Russia
Vladimir V. Vasin, Krasovskii Institute of Mathematics and Mechanics, Ural Branch of the Russian Academy of Sciences, Ekaterinburg, Russia
Mikhail V. Volkov, Ural Federal University, Ekaterinburg, Russia

EDITORIAL BOARD

Elena N. Akimova, Krasovskii Institute of Mathematics and Mechanics, Ural Branch of the Russian Academy of Sciences, Ekaterinburg, Russia
Alexander G. Babenko, Krasovskii Institute of Mathematics and Mechanics, Ural Branch of the Russian Academy of Sciences, Ekaterinburg, Russia
Vitalii A. Baranskii, Ural Federal University, Ekaterinburg, Russia
Elena E. Berdysheva, Department of Mathematics, Justus Liebig University, Giessen, Germany
Alexey R. Danilin, Krasovskii Institute of Mathematics and Mechanics, Ural Branch of the Russian Academy of Sciences, Ekaterinburg, Russia
Yuri F. Dolgii, Ural Federal University, Ekaterinburg, Russia
Vakif Dzhafarov (Cafer), Department of Mathematics, Anadolu University, Eskişehir, Turkey
Polina Yu. Glazyrina, Ural Federal University, Ekaterinburg, Russia
Mikhail I. Gusev, Krasovskii Institute of Mathematics and Mechanics, Ural Branch of the Russian Academy of Sciences, Ekaterinburg, Russia
Éva Gyurkovics, Department of Differential Equations, Institute of Mathematics, Budapest University of Technology and Economics, Budapest, Hungary
Marc Jungers, National Center for Scientific Research (CNRS), CRAN, Nancy and Université de Lorraine, CRAN, Nancy, France
Mikhail Yu. Khachay, Krasovskii Institute of Mathematics and Mechanics, Ural Branch of the Russian Academy of Sciences, Ekaterinburg, Russia
Anatolii F. Kleimenov, Krasovskii Institute of Mathematics and Mechanics, Ural Branch of the Russian Academy of Sciences, Ekaterinburg, Russia
Anatoly S. Kondratiev, Krasovskii Institute of Mathematics and Mechanics, Ural Branch of the Russian Academy of Sciences, Ekaterinburg, Russia
Vyacheslav I. Maksimov, Krasovskii Institute of Mathematics and Mechanics, Ural Branch of the Russian Academy of Sciences, Ekaterinburg, Russia
Tapio Palokangas, University of Helsinki, Helsinki, Finland
Emanuele Rodaro, Politecnico di Milano, Department of Mathematics, Italy
Dmitrii A. Serkov, Krasovskii Institute of Mathematics and Mechanics, Ural Branch of the Russian Academy of Sciences, Ekaterinburg, Russia
Alexander N. Seseikin, Ural Federal University, Ekaterinburg, Russia
Alexander M. Tarasyev, Krasovskii Institute of Mathematics and Mechanics, Ural Branch of the Russian Academy of Sciences, Ekaterinburg, Russia

MANAGING EDITOR

Oxana G. Matviychuk, Krasovskii Institute of Mathematics and Mechanics, Ural Branch of the Russian Academy of Sciences, Ekaterinburg, Russia

TECHNICAL ADVISOR

Alexey N. Borbunov, Ural Federal University, Krasovskii Institute of Mathematics and Mechanics, Russian Academy of Sciences, Ekaterinburg, Russia

TABLE OF CONTENTS

<i>Liju Alex, Indulal Gopalapillai</i> ZAGREB INDICES OF A NEW SUM OF GRAPHS	4–17
<i>Md. Yasin Ali</i> SOME TRIGONOMETRIC SIMILARITY MEASURES OF COMPLEX FUZZY SETS WITH APPLICATION	18–28
<i>Vitaly A. Baransky, Tatiana A. Senchonok</i> AROUND THE ERDÖS–GALLAI CRITERION	29–48
<i>Subhajit Bera, Binod Chandra Tripathy</i> STATISTICAL CONVERGENCE IN A BICOMPLEX VALUED METRIC SPACE....	49–63
<i>Indrani Dutta, Sukhendu Kar</i> TERNARY *-BANDS ARE GLOBALLY DETERMINED	64–77
<i>Hamza El Bazi, Abdellatif Sadrati</i> WEIGHTED S^p -PSEUDO S -ASYMPTOTICALLY PERIODIC SOLUTIONS FOR SOME SYSTEMS OF NONLINEAR DELAY INTEGRAL EQUATIONS WITH SUPERLINEAR PERTURBATION	78–92
<i>Anar Huseyin, Nesir Huseyin</i> ON THE PROPERTIES OF THE SET OF TRAJECTORIES OF THE NONLINEAR CONTROL SYSTEM WITH QUADRATIC INTEGRAL CONSTRAINT ON THE CONTROL FUNCTIONS	93–103
<i>Mohd Yousf Mir, Shah Lubna Wali, Wali Mohammad Shah</i> INEQUALITIES FOR A CLASS OF MEROMORPHIC FUNCTIONS WHOSE ZEROS ARE WITHIN OR OUTSIDE A GIVEN DISK	104–112
<i>Zahid Bashir Monga, Wali Mohammad Shah</i> ON CAUCHY-TYPE BOUNDS FOR THE EIGENVALUES OF A SPECIAL CLASS OF MATRIX POLYNOMIALS	113–120
<i>Athira P. Ranjith, Joseph Varghese Kureethara</i> SUM SIGNED GRAPHS – II	121–126
<i>Vladimir B. Repnitskiĭ</i> LATTICE UNIVERSALITY OF LOCALLY FINITE p -GROUPS	127–134
<i>Ksenia Rizhenko, Katherine Neznakhina, Michael Khachay</i> FIXED RATIO POLYNOMIAL TIME APPROXIMATION ALGORITHM FOR THE PRIZE-COLLECTING ASYMMETRIC TRAVELING SALESMAN PROBLEM.....	135–146
<i>Alexander N. Seseĭin, Anna D. Kandrĭna</i> HYERS–ULAM–RASSIAS STABILITY OF NONLINEAR DIFFERENTIAL EQUATIONS WITH A GENERALIZED ACTIONS ON THE RIGHT-HAND SIDE...	147–152

<i>Ruslan Yu. Simanchev, Inna V. Urazova, Vladimir V. Voroshilov</i> THE MINIMAL DOMINATING SETS IN A DIRECTED GRAPH AND THE KEY INDICATORS SET OF SOCIO-ECONOMIC SYSTEM	153–161
<i>B. Somasudaram, S. Karpagam, R. Lokesh, A. Kavin Sagana Mary</i> AN $M^{[X]}/G/1$ QUEUE WITH OPTIONAL SERVICE AND WORKING BREAKDOWN	162–175
<i>Srinivasarao Thota, Tekle Gemechu, Abayomi Ayotunde Ayode</i> ON NEW HYBRID ROOT-FINDING ALGORITHMS FOR SOLVING TRANSCENDENTAL EQUATIONS USING EXPONENTIAL AND HALLEY'S METHODS	176–186
<i>Natalia P. Volchkova, Vitaliy V. Volchkov</i> ON ONE ZALCMAN PROBLEM FOR THE MEAN VALUE OPERATOR.....	187–200

ZAGREB INDICES OF A NEW SUM OF GRAPHS

Liju Alex

Department of Mathematics, Bishop Chulaprambil Memorial College(B.C.M),
Kottayam - 686001, India

Marthoma College,
Thiruvalla, Pathanamthitta - 689103, India

lijualex0@gmail.com

Indulal Gopalapillai

Department of Mathematics, St.Aloysius College,
Edathua, Alappuzha - 689573, India

indulalgopal@gmail.com

Abstract: The first and second Zagreb indices, since its inception have been subjected to extensive research in the physio-chemical analysis of compounds. In [5], Hanyuan Deng *et al.* computed the first and second Zagreb indices of four new operations on a graph defined by M. Eliasi, B. Taeri [6]. Motivated by [6], in this paper we define a new operation on graphs and compute the first and second Zagreb indices of the resultant graph. We illustrate the results with some examples.

Keywords: First Zagreb index $M_1(G)$, Second Zagreb index $M_2(G)$, F^* sum.

1. Introduction

A graph without loops and also without parallel edges is called a simple graph and if all the pairs of vertices of the graph are connected by a path then it is said to be connected. Throughout our discussion, we consider only connected simple graphs. The degree-based structural descriptors have been a subject of detailed study since their induction from the first degree-based topological index in 1972 by I. Gutman, N. Trinajstić [11]. Later, in 1975 I. Gutman, B. Rusćić, N. Trinajstić, C.F. Wilcox [12] defined another degree based index in connection with studying physical properties of chemical compounds. At first, both these indices were named as Zagreb group indices [3], but later I. Gutman named them as first and second Zagreb indices. The first Zagreb index $M_1(G)$ is defined as the sum of squares of degrees of all the vertices and the second Zagreb index $M_2(G)$ is defined as the sum of product of degrees of end vertices of all the edges. That is,

$$M_1(G) = \sum_{u \in V(G)} d_G(u)^2, \quad M_2(G) = \sum_{uv \in E(G)} d_G(u)d_G(v).$$

Various physical applications of these indices can be found in [8–10, 13, 19, 20]. A more unified and general approach on degree based indices of graphs were considered by X. Li, H. Zhao in [17, 18] which lead in defining generalized Zagreb index as

$$M_\alpha(G) = \sum_{u \in V(G)} d_G(u)^\alpha.$$

Various particular cases for this generalized Zagreb index were considered separately, one among them is the Forgotten index $F(G)$ (when $\alpha = 3$) defined in 1972 [11] but resurged in 2015 through the works of B. Furtula, I. Gutman [7]. For more works on topological indices, see [2, 15, 17, 18, 21]. The degree based topological indices of graph operations have been a subject of detailed study recently [1, 5]. In [16], M.H. Khalifeh, H. Yousefi–Azari, A.R. Ashrafi computed the first and second Zagreb indices of graph operations such as cartesian product, composition, join, disjunction and symmetric difference of graphs. In [6], M. Eliasi, B. Taeri defined four new operations of graphs related to subdivisions and computed the Wiener index. Motivated by [6], in this paper we define a new sum related to the four subdivision graphs and compute the first and second Zagreb indices of the new sum. We also find the Zagreb indices of some chemical structures and some classes of bridge graphs using the expressions obtained. We refer to this new sum as F^* sums of graphs.

2. F^* sums of graphs

Let G_1, G_2 be two graphs with vertex set V_1, V_2 and edge set E_1, E_2 respectively. The four subdivision graphs $S(G_1), R(G_1), Q(G_1), T(G_1)$ are defined as follows in [4]:

1. $S(G_1)$ is the graph obtained from G_1 by replacing each edge e_i of G_1 with a vertex and making the new vertex adjacent to the corresponding end vertices of e_i for each $e_i \in E_1$. That is, $S(G_1)$ is a graph with vertex set $V(S(G_1)) = V_1 \cup V_1^*$ where V_1^* is the collection of new vertices and the edge set

$$E(S(G_1)) = \{(v, h), (u, h) : e = vu \in E_1, h \in V_1^*\}.$$

2. $R(G_1)$ is the graph obtained from G_1 by replacing each edge e_i of G_1 with a vertex and making new vertex adjacent to the corresponding end vertices of e_i for each $e_i \in E_1$ also keeping every edge in G_1 as well. That is, $R(G_1)$ is a graph with vertex set $V(R(G_1)) = V_1 \cup V_1^*$ where V_1^* is the collection of new vertices and edge set

$$E(R(G_1)) = \{(v, h), (u, h) : e = vu \in E_1, h \in V_1^*\} \cup E_1.$$

3. $Q(G_1)$ is the graph obtained from G_1 by replacing each edge e_i of G_1 with a vertex and making new vertex adjacent to the corresponding end vertices of e_i for each $e_i \in E_1$ along with edges joining vertex in the i th copy of V_1^* to the vertex in the j th copy of V_1^* whenever e_i adjacent to e_j in G_1 . That is, $Q(G_1)$ is a graph with vertex set $V(Q(G_1)) = V_1 \cup V_1^*$ where V_1^* is the collection of new vertices and edge set

$$E(Q(G_1)) = \{(v, h), (u, h) : e = vu \in E_1, h \in V_1^*\} \cup E_1^*,$$

$$E_1^* = \{(u_i, u_j) : e_i \text{ adjacent to } e_j \text{ in } E_1, u_i, u_j \in V_1^*\},$$

where u_i, u_j are the vertices corresponding to the edges $e_i, e_j \in E_1$.

4. $T(G_1)$ is the graph obtained from G_1 by replacing each edge e_i of G_1 with a vertex and making new vertex adjacent to the corresponding end vertices of e_i for each $e_i \in E_1$ along with edges joining vertex in the i th copy of V_1^* to the vertex in the j th copy of V_1^* whenever e_i adjacent to e_j in G_1 and keeping every edge of G_1 as well. That is, $T(G_1)$ is a graph with vertex set $V(T(G_1)) = V_1 \cup V_1^*$ where V_1^* is the collection of new vertices and edge set

$$E(T(G_1)) = \{(v, h), (u, h) : e = vu \in E_1, h \in V_1^*\} \cup E_1^*,$$

$$E_1^* = \{(u_i, u_j) : e_i \text{ adjacent to } e_j \text{ in } E_1, u_i, u_j \in V_1^*\} \cup E_1,$$

where u_i, u_j are the vertices corresponding to the edges $e_i, e_j \in E_1$.

In each of these new subdivision graphs the vertices V_1 can be termed as black vertices and the vertices V_1^* can be termed as white vertices. In [6], M. Eliasi, B. Taeri defined four new sums called F sums with the operation cartesian product on black vertices on copies of subdivision graphs. Motivated by this we define a sum on copies of white vertices related to the cartesian product. Let F be any one of the symbols S, R, Q, T , then the F^* sum of two graphs G_1 and G_2 is denoted by $G_1 *_{F^*} G_2$, is a graph with the vertex set $V(G_1 *_{F^*} G_2) = V(F(G_1)) \times V_2$ and the edge set

$$E(G_1 *_{F^*} G_2) = \{(a, b)(c, d) : a = c \in V_1^* \text{ and } bd \in E_2 \text{ or } ac \in E(F(G_1)) \text{ and } b = d \in V_2\}.$$

Fig. 1 is an example with $G_1 = P_4$, $G_2 = P_6$.

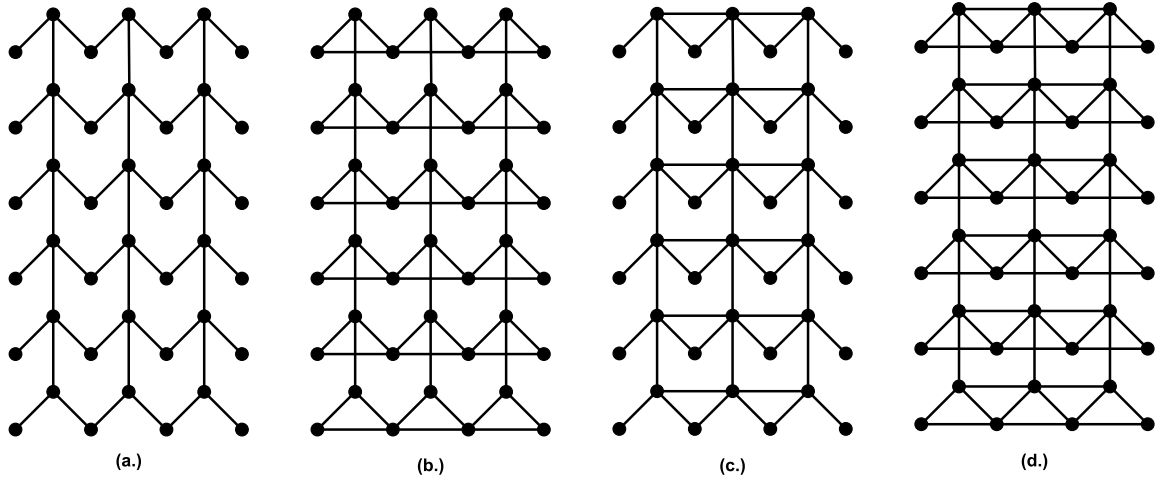

Figure 1. (a) $P_4 *_{S^*} P_6$, (b) $P_4 *_{R^*} P_6$, (c) $P_4 *_{Q^*} P_6$, (d) $P_4 *_{T^*} P_6$.

3. Zagreb index of F^* sum

In this section we compute the first and second Zagreb indices of F^* sums of graphs.

Theorem 1. *Let G_1 and G_2 be two connected graphs, then*

- (a) $M_1(G_1 *_{S^*} G_2) = |V_2|M_1(G_1) + |E_1|M_1(G_2) + 4|E_1|(2|E_2| + |V_2|),$
- (b) $M_2(G_1 *_{S^*} G_2) = 2|E_1|M_1(G_2) + |E_1|M_2(G_2) + 4|E_1|(2|E_2| + |V_2|).$

P r o o f. From the definition of first Zagreb index, we have

$$\begin{aligned} M_1(G_1 *_{S^*} G_2) &= \sum_{(a,b) \in V(G_1 *_{S^*} G_2)} (d_{(G_1 *_{S^*} G_2)}(a, b))^2 \\ &= \sum_{(u,v)(x,y) \in E(G_1 *_{S^*} G_2)} (d_{(G_1 *_{S^*} G_2)}(u, v) + d_{(G_1 *_{S^*} G_2)}(x, y)) \\ &= \sum_{u \in V_1^*} \sum_{vy \in E_2} (d_{(G_1 *_{S^*} G_2)}(u, v) + d_{(G_1 *_{S^*} G_2)}(u, y)) \\ &+ \sum_{v \in V_2} \sum_{ux \in E(S(G_1))} (d_{(G_1 *_{S^*} G_2)}(u, v) + d_{(G_1 *_{S^*} G_2)}(x, v)). \end{aligned}$$

Now we separately find the values of the each parts in the sum. Firstly we consider the sum in which $u \in V_1^*$ and $vy \in E_2$

$$\begin{aligned}
& \sum_{u \in V_1^*} \sum_{vy \in E_2} (d_{(G_1 * S G_2)}(u, v) + d_{(G_1 * S G_2)}(u, y)) \\
&= \sum_{u \in V_1^*} \sum_{vy \in E_2} [d_{S(G_1)}(u) + d_{G_2}(v) + (d_{S(G_1)}(u) + d_{G_2}(y))] \\
&= \sum_{u \in V_1^*} \sum_{vy \in E_2} [2d_{S(G_1)}(u) + d_{G_2}(v) + d_{G_2}(y)] \\
&= \sum_{u \in V_1^*} [4|E_2| + M_1(G_2)] = 4|E_1||E_2| + |E_1|M_1(G_2).
\end{aligned}$$

Now for each edge $ux \in E(S(G_1))$, $v \in V_2$

$$\begin{aligned}
& \sum_{v \in V_2} \sum_{ux \in E(S(G_1))} (d_{(G_1 * S G_2)}(u, v) + d_{(G_1 * S G_2)}(x, v)) \\
&= \sum_{v \in V_2} \sum_{\substack{ux \in E(S(G_1)) \\ u \in V_1, x \in V_1^*}} [d_{S(G_1)}(u) + (d_{G_2}(v) + d_{S(G_1)}(x))] \\
&= \sum_{v \in V_2} (2|E_1|d_{G_2}(v) + M_1(G_1) + 4|E_1|) = 4|E_1||E_2| + |V_2|M_1(G_1) + 4|E_1||V_2|.
\end{aligned}$$

From the expressions we obtain

$$M_1(G_1 * S G_2) = |V_2|M_1(G_1) + |E_1|M_1(G_2) + 4|E_1|(2|E_2| + |V_2|).$$

Next consider

$$\begin{aligned}
M_2(G_1 * S G_2) &= \sum_{(u,v)(x,y) \in E(G_1 * S G_2)} (d_{G_1 * S G_2}(u, v)d_{G_1 * S G_2}(x, y)) \\
&= \sum_{u \in V_1^*} \sum_{vy \in E_2} (d_{G_1 * S G_2}(u, v)d_{G_1 * S G_2}(u, y)) + \sum_{v \in V_2} \sum_{ux \in E(S(G_1))} (d_{G_1 * S G_2}(u, v)d_{G_1 * S G_2}(x, v)) \\
&= \sum_{u \in V_1^*} \sum_{vy \in E_2} [d_{S(G_1)}(u) + d_{G_2}(v)] [d_{S(G_1)}(u) + d_{G_2}(y)] \\
&\quad + \sum_{\substack{v \in V_2 \\ ux \in E(S(G_1)), \\ u \in V_1, x \in V_1^*}} [d_{S(G_1)}(u) (d_{G_2}(v) + d_{S(G_1)}(x))] \\
&= \sum_{u \in V_1^*} \sum_{vy \in E_2} [4 + 2(d_{G_2}(v) + d_{G_2}(y)) + d_{G_2}(v)d_{G_2}(y)] + \sum_{v \in V_2} (2(|E_1|)d_{G_2}(v) + 4|E_1|) \\
&= 4|E_1||E_2| + 2|E_1|M_1(G_2) + |E_1|M_2(G_2) + 4|E_1|(|E_2| + |V_2|).
\end{aligned}$$

Thus,

$$M_2(G_1 * S G_2) = 2|E_1|M_1(G_2) + |E_1|M_2(G_2) + 4|E_1|(2|E_2| + |V_2|).$$

□

Theorem 2. *Let G_1 and G_2 be two connected graphs, then*

- (a) $M_1(G_1 *_R G_2) = 4|V_2|M_1(G_1) + |E_1|M_1(G_2) + 4|E_1|(2|E_2| + |V_2|)$,
 (b) $M_2(G_1 *_R G_2) = 4M_1(G_1)(1 + |E_2|) + M_2(G_2)(4|V_2| + |E_1|) + 2|E_1|M_1(G_2) + 4|E_1||E_2|$.

P r o o f. We have

$$\begin{aligned} M_1(G_1 *_R G_2) &= \sum_{(a,b) \in V(G_1 *_R G_2)} (d_{(G_1 *_R G_2)}(a, b))^2 \\ &= \sum_{(u,v)(x,y) \in E(G_1 *_R G_2)} (d_{(G_1 *_R G_2)}(u, v) + d_{(G_1 *_R G_2)}(x, y)) \\ &= \sum_{u \in V_1^*} \sum_{vy \in E_2} (d_{(G_1 *_R G_2)}(u, v) + d_{(G_1 *_R G_2)}(u, y)) + \sum_{v \in V_2} \sum_{ux \in E(R(G_1))} (d_{(G_1 *_R G_2)}(u, v) + d_{(G_1 *_R G_2)}(x, v)). \end{aligned}$$

Now we separately find the values of each part in the sum. First we consider the sum in which $u \in V_1^*$ and $vy \in E_2$

$$\begin{aligned} &\sum_{u \in V_1^*} \sum_{vy \in E_2} (d_{(G_1 *_R G_2)}(u, v) + d_{(G_1 *_R G_2)}(u, y)) \\ &= \sum_{u \in V_1^*} \sum_{vy \in E_2} [(d_{R(G_1)}(u) + d_{G_2}(v)) + (d_{R(G_1)}(u) + d_{G_2}(y))] \\ &= \sum_{u \in V_1^*} \sum_{vy \in E_2} [4 + d_{G_2}(v) + d_{G_2}(y)] = \sum_{u \in V_1^*} [4|E_2| + M_1(G_2)] = 4|E_1||E_2| + |E_1|M_1(G_2). \end{aligned}$$

Now for each edge $ux \in E(R(G_1))$, $v \in V_2$

$$\begin{aligned} &\sum_{v \in V_2} \sum_{ux \in E(R(G_1))} (d_{(G_1 *_R G_2)}(u, v) + d_{(G_1 *_R G_2)}(x, v)) \\ &= \sum_{v \in V_2} \sum_{\substack{ux \in E(R(G_1)), \\ u, x \in V_1}} (d_{(G_1 *_R G_2)}(u, v) + d_{(G_1 *_R G_2)}(x, v)) \\ &+ \sum_{v \in V_2} \sum_{\substack{ux \in E(R(G_1)), \\ u \in V_1, x \in V_1^*}} (d_{(G_1 *_R G_2)}(u, v) + d_{(G_1 *_R G_2)}(x, v)). \end{aligned}$$

Now we calculate the each sum separately

$$\begin{aligned} &\sum_{v \in V_2} \sum_{\substack{ux \in E(R(G_1)), \\ u, x \in V_1}} (d_{(G_1 *_R G_2)}(u, v) + d_{(G_1 *_R G_2)}(x, v)) \\ &= \sum_{v \in V_2} \sum_{\substack{ux \in E(R(G_1)), \\ u, x \in V_1^*}} (d_{R(G_1)}(u) + d_{R(G_1)}(x)) \\ &= \sum_{v \in V_2} \sum_{\substack{ux \in E(R(G_1)), \\ u, x \in V_1}} 2(d_{G_1}(u) + d_{G_1}(x)) = 2|V_2|M_1(G_1). \end{aligned}$$

By considering the case where $ux \in E(R(G_1))$, $u \in V_1$, $x \in V_1^*$

$$\begin{aligned} \sum_{v \in V_2} \sum_{\substack{ux \in E(R(G_1)), \\ u \in V_1^*, x \in V_1^*}} (d_{(G_1 * R G_2)}(u, v) + d_{(G_1 * R G_2)}(x, v)) &= \sum_{v \in V_2} \sum_{\substack{ux \in E(R(G_1)), \\ u \in V_1, x \in V_1^*}} d_{R(G_1)}(u) + (d_{G_2}(v) + 2) \\ &= \sum_{v \in V_2} \sum_{\substack{ux \in E(R(G_1)), \\ u \in V_1, x \in V_1^*}} 2d_{G_1}(u) + d_{G_2}(v) + 2 = 2|V_2|M_1(G_1) + 4|E_1|(|E_2| + |V_2|). \end{aligned}$$

Thus we obtain

$$M_1(G_1 * R G_2) = 4|V_2|M_1(G_1) + |E_1|M_1(G_2) + 4|E_1|(2|E_2| + |V_2|).$$

Similarly,

$$\begin{aligned} M_2(G_1 * R G_2) &= \sum_{(u,v)(x,y) \in E(G_1 * R G_2)} (d_{G_1 * R G_2}(u, v)d_{G_1 * R G_2}(x, y)) \\ &= \sum_{u \in V_1^*} \sum_{vy \in E_2} (d_{G_1 * R G_2}(u, v)d_{G_1 * R G_2}(u, y)) + \sum_{v \in V_2} \sum_{ux \in E(R(G_1))} (d_{G_1 * R G_2}(u, v)d_{G_1 * R G_2}(x, v)). \end{aligned}$$

Now we find the sums separately

$$\begin{aligned} \sum_{u \in V_1^*} \sum_{vy \in E_2} (d_{G_1 * R G_2}(u, v)d_{G_1 * R G_2}(u, y)) &= \sum_{u \in V_1^*} \sum_{vy \in E_2} [(d_{R(G_1)}(u) + d_{G_2}(v))(d_{R(G_1)}(u) + d_{G_2}(y))] \\ &= \sum_{u \in V_1^*} \sum_{vy \in E_2} [d_{R(G_1)}(u)^2 + d_{R(G_1)}(u)(d_{G_2}(v) + d_{G_2}(y)) + d_{G_2}(v)d_{G_2}(y)] \\ &= \sum_{u \in V_1^*} \sum_{vy \in E_2} [4 + 2(d_{G_2}(v) + d_{G_2}(y)) + d_{G_2}(v)d_{G_2}(y)] = 4|E_1||E_2| + 2|E_1|M_1(G_2) + |E_1|M_2(G_2). \end{aligned}$$

Also,

$$\begin{aligned} \sum_{v \in V_2} \sum_{ux \in E(R(G_1))} (d_{G_1 * R G_2}(u, v)d_{G_1 * R G_2}(x, v)) &= \sum_{v \in V_2} \sum_{\substack{ux \in E(R(G_1)), \\ u, x \in V_1}} (d_{G_1 * R G_2}(u, v)d_{G_1 * R G_2}(x, v)) \\ &\quad + \sum_{\substack{v \in V_2 \\ u \in V_1, x \in V_1^*}} \sum_{ux \in E(R(G_1))} (d_{G_1 * R G_2}(u, v)d_{G_1 * R G_2}(x, v)). \end{aligned}$$

Finding the sums separately, we get

$$\begin{aligned} \sum_{v \in V_2} \sum_{\substack{ux \in E(R(G_1)) \\ u, x \in V_1}} (d_{G_1 * R G_2}(u, v)d_{G_1 * R G_2}(x, v)) &= \sum_{v \in V_2} \sum_{\substack{ux \in E(R(G_1)) \\ u, x \in V_1}} (d_{R(G_1)}(u)d_{R(G_1)}(x)) \\ &= \sum_{v \in V_2} \sum_{\substack{ux \in E(R(G_1)) \\ u, x \in V_1}} 4d_{G_1}(u)d_{G_1}(x) = 4|V_2|M_2(G_2). \end{aligned}$$

Now,

$$\begin{aligned} \sum_{v \in V_2} \sum_{\substack{ux \in E(R(G_1)) \\ u \in V_1, x \in V_1^*}} (d_{G_1 * R G_2}(u, v)d_{G_1 * R G_2}(x, v)) &= \sum_{v \in V_2} \sum_{\substack{ux \in E(R(G_1)) \\ u \in V_1, x \in V_1^*}} d_{R(G_1)}(u)(d_{G_2}(v) + d_{R(G_1)}(x)) \\ &= \sum_{v \in V_2} \sum_{\substack{ux \in E(R(G_1)) \\ u \in V_1, x \in V_1^*}} 4d_{G_1}(u) + 2d_{G_1}(u)d_{G_2}(v) = 4M_1(G_1) + 4|E_2|M_1(G_1). \end{aligned}$$

Now collecting all the previous terms, we get

$$M_2(G_1 *_R G_2) = 4M_1(G_1)(1 + |E_2|) + M_2(G_2)(4|V_2| + |E_1|) + 2|E_1|M_1(G_2) + 4|E_1||E_2|.$$

□

Theorem 3. *Let G_1 and G_2 be two connected graphs, then*

$$\begin{aligned} (a) \quad M_1(G_1 *_Q G_2) &= (|V_2| + 2|E_2|)M_1(G_1) + |E_1|M_1(G_2) + 2|V_2|M_2(G_1) \\ &\quad + |V_2|F(G_1) + 2|E_2|(2|E(Q(G_1))| + 3|E_1|), \\ (b) \quad M_2(G_1 *_Q G_2) &= |E_2|M_2(G_1) + |E_1|M_2(G_2) + M_2(G_1)M_2(G_2) + 2|E_2|M_1(G_1) \\ &\quad + \frac{1}{2}[|V_2|M_4(G_1) + (2|E_2| + |V_2|F(G_1))] \\ &\quad + |V_2|\left(\sum_{u_i, u_j \in V_1} r_{ij}d_{G_1}(u_i)d_{G_1}(u_j) + \sum_{u_j \in V_1} d_{G_1}(u_j)^2 \sum_{u_i \in V_1, u_i u_j \in E_1} d_{G_1}(u_i)\right), \end{aligned}$$

where r_{ij} denotes the number of neighbouring common vertices adjacent to both u_i and u_j .

P r o o f. We have

$$\begin{aligned} M_1(G_1 *_Q G_2) &= \sum_{(a,b) \in V(G_1 *_S G_2)} (d_{(G_1 *_Q G_2)}(a,b))^2 \\ &= \sum_{(u,v)(x,y) \in E(G_1 *_Q G_2)} (d_{(G_1 *_Q G_2)}(u,v) + d_{(G_1 *_Q G_2)}(x,y)) \\ &= \sum_{u \in V_1^*} \sum_{vy \in E_2} (d_{(G_1 *_Q G_2)}(u,v) + d_{(G_1 *_Q G_2)}(u,y)) \\ &\quad + \sum_{v \in V_2} \sum_{ux \in E(Q(G_1))} (d_{(G_1 *_Q G_2)}(u,v) + d_{(G_1 *_Q G_2)}(x,v)). \end{aligned}$$

First we consider the sum in which $u \in V_1^*$ and $vy \in E_2$

$$\begin{aligned} &\sum_{u \in V_1^*} \sum_{vy \in E_2} (d_{(G_1 *_Q G_2)}(u,v) + d_{(G_1 *_Q G_2)}(u,y)) \\ &= \sum_{u \in V_1^*} \sum_{vy \in E_2} [(d_{Q(G_1)}(u) + d_{G_2}(v)) + (d_{Q(G_1)}(u) + d_{G_2}(y))] \\ &= \sum_{u \in V_1^*} \sum_{vy \in E_2} [2d_{Q(G_1)}(u) + d_{G_2}(v) + d_{G_2}(y)] \\ &= \sum_{e=pq \in E_1} 2|E_2|(d_{G_1}(p) + d_{G_1}(q)) + \sum_{u \in V_1^*} M_1(G_2) = 2|E_2|M_1(G_1) + |E_1|M_1(G_2). \end{aligned}$$

For each edge $ux \in E(Q(G_1))$ and the vertex $v \in V_2$

$$\begin{aligned} &\sum_{v \in V_2} \sum_{ux \in E(Q(G_1))} (d_{(G_1 *_Q G_2)}(u,v) + d_{(G_1 *_Q G_2)}(x,v)) \\ &= \sum_{v \in V_2} \sum_{\substack{ux \in E(Q(G_1)), \\ u \in V_1, x \in V_1^*}} (d_{(G_1 *_Q G_2)}(u,v) + d_{(G_1 *_Q G_2)}(x,v)) \\ &\quad + \sum_{v \in V_2} \sum_{\substack{ux \in E(Q(G_1)), \\ u, x \in V_1^*}} (d_{(G_1 *_Q G_2)}(u,v) + d_{(G_1 *_Q G_2)}(x,v)). \end{aligned}$$

Now we separately find both the sums. First,

$$\begin{aligned}
& \sum_{v \in V_2} \sum_{\substack{ux \in E(Q(G_1)) \\ u \in V_1, x \in V_1^*}} \left(d_{(G_1 * Q G_2)}(u, v) + d_{(G_1 * Q G_2)}(x, v) \right) \\
= & \sum_{v \in V_2} \sum_{\substack{ux \in E(Q(G_1)) \\ u \in V_1, x \in V_1^*}} d_{Q(G_1)}(u) + (d_{G_2}(v) + d_{Q(G_1)}(x)) = \sum_{v \in V_2} \sum_{\substack{ux \in E(Q(G_1)) \\ u \in V_1, x \in V_1^*}} d_{G_1}(u) + d_{G_2}(v) + d_{Q(G_1)}(x) \\
= & \sum_{v \in V_2} M_1(G_1) + 2|E_1|d_{G_2}(v) + 2 \sum_{v \in V_2} \sum_{\substack{e=uv_i \in E(G_1) \\ u_i, v_i \in V_1}} (d_{G_1}(u_i) + d_{G_1}(v_i)) \\
= & |V_2|M_1(G_1) + 4|E_1||E_2| + 2|V_2|M_1(G_1).
\end{aligned}$$

The second part of the sum is the following

$$\begin{aligned}
& \sum_{v \in V_2} \sum_{\substack{ux \in E(Q(G_1)), \\ u, x \in V_1^*}} \left(d_{(G_1 * Q G_2)}(u, v) + d_{(G_1 * Q G_2)}(x, v) \right) \\
= & \sum_{v \in V_2} \sum_{\substack{ux \in E(Q(G_1)), \\ u, x \in V_1^*}} (d_{Q(G_1)}(u) + d_{G_2}(v) + d_{Q(G_1)}(x) + d_{G_2}(v)) \\
= & \sum_{v \in V_2} \left(\sum_{\substack{ux \in E(Q(G_1)), \\ u, x \in V_1^*}} 2d_{G_2}(v) \right) + \sum_{v \in V_2} \left(\sum_{\substack{ux \in E(Q(G_1)), \\ u, x \in V_1^*}} (d_{Q(G_1)}(u) + d_{Q(G_1)}(x)) \right) \\
= & \sum_{v \in V_2} \left(\sum_{\substack{ux \in E(Q(G_1)), \\ u, x \in V_1^*}} 2d_{G_2}(v) \right) + \sum_{v \in V_2} \left(\sum_{u_i u_j, u_j u_k \in E_1} (d_{G_1}(u_i) + d_{G_1}(u_j) + d_{G_1}(u_j) + d_{G_1}(u_k)) \right) \\
= & 4(|E(Q(G_1))| - 2|E_1|)|E_2| + |V_2| \left(2 \sum_{u_j \in V_1} C_{d_{G_1}(u_j)}^2 d_{G_1}(u_j) + \sum_{u_j \in V_1} (d_{G_1}(u_j) - 1) \sum_{\substack{u_i \in V_1, \\ u_i u_j \in E_1}} d_{G_1}(u_i) \right) \\
= & 4(|E(Q(G_1))| - 2|E_1|)|E_2| + |V_2| \left(\sum_{u_j \in V_1} (d_{G_1}(u_j)^3 - d_{G_1}(u_j)^2) + \sum_{u_j \in V_1} (d_{G_1}(u_j) - 1) \sum_{\substack{u_i \in V_1, \\ u_i u_j \in E_1}} d_{G_1}(u_i) \right) \\
= & 4(|E(Q(G_1))| - 2|E_1|)|E_2| + |V_2|(F(G_1) + 2M_2(G_1) - 2M_1(G_1)).
\end{aligned}$$

Here $u_i u_j$ is the edge corresponding to the vertex u and $u_j u_k$ is the edge corresponding to the vertex x .

Thus we obtain

$$\begin{aligned}
M_1(G_1 * Q G_2) = & (|V_2| + 2|E_2|)M_1(G_1) + |E_1|M_1(G_2) + 2|V_2|M_2(G_1) \\
& + |V_2|F(G_1) + 2|E_2|(2|E(Q(G_1))| + 3|E_1|).
\end{aligned}$$

Similarly,

$$\begin{aligned}
M_2(G_1 * Q G_2) = & \sum_{(u,v)(x,y) \in E(G_1 * Q G_2)} (d_{(G_1 * Q G_2)}(u, v)d_{(G_1 * Q G_2)}(x, y)) \\
= & \sum_{u \in V_1^*} \sum_{vy \in E_2} (d_{(G_1 * Q G_2)}(u, v)d_{(G_1 * Q G_2)}(u, y)) + \sum_{v \in V_2} \sum_{ux \in E(Q(G_1))} (d_{(G_1 * Q G_2)}(u, v)d_{(G_1 * Q G_2)}(x, v)).
\end{aligned}$$

Now we separately find the values of each part in the sum

$$\begin{aligned}
& \sum_{u \in V_1^*} \sum_{vy \in E_2} (d_{(G_1 * Q G_2)}(u, v) d_{(G_1 * Q G_2)}(u, y)) = \sum_{u \in V_1^*} \sum_{vy \in E_2} [(d_{Q(G_1)}(u) + d_{G_2}(v)) (d_{Q(G_1)}(u) + d_{G_2}(y))] \\
&= \sum_{u \in V_1^*} \sum_{vy \in E_2} [d_{Q(G_1)}(u)^2 + d_{Q(G_1)}(u) (d_{G_2}(v) + d_{G_2}(y)) + d_{G_2}(v) d_{G_2}(y)] \\
&= \sum_{vy \in E_2} \sum_{u_i u_j \in E_1} (d_{G_1}(u_i) + d_{G_1}(u_j))^2 + \sum_{u_i u_j \in E_1} \sum_{vy \in E_2} (d_{G_1}(u_i) + d_{G_1}(u_j)) (d_{G_2}(v) + d_{G_2}(y)) \\
&\quad + \sum_{u_i u_j \in E_1} \sum_{vy \in E_2} d_{G_2}(v) d_{G_2}(y) \\
&= \sum_{vy \in E_2} \sum_{u_i u_j \in E_1} (d_{G_1}(u_i)^2 + d_{G_1}(u_j)^2 + 2d_{G_1}(u_i) d_{G_1}(u_j)) + M_2(G_1) M_2(G_2) + |E_1| M_2(G_2) \\
&= |E_2| F(G_1) + 2|E_2| M_2(G_1) + M_2(G_1) M_2(G_2) + |E_1| M_2(G_2).
\end{aligned}$$

Now,

$$\begin{aligned}
& \sum_{v \in V_2} \sum_{ux \in E(Q(G_1))} (d_{(G_1 * Q G_2)}(u, v) d_{(G_1 * Q G_2)}(x, v)) = \sum_{v \in V_2} \sum_{\substack{ux \in E(Q(G_1)), \\ u \in V_1, x \in V_1^*}} (d_{(G_1 * Q G_2)}(u, v) d_{(G_1 * Q G_2)}(x, v)) \\
&\quad + \sum_{v \in V_2} \sum_{\substack{ux \in E(Q(G_1)), \\ u, x \in V_1^*}} (d_{(G_1 * Q G_2)}(u, v) d_{(G_1 * Q G_2)}(x, v)).
\end{aligned}$$

Now we find each sum separately

$$\begin{aligned}
& \sum_{v \in V_2} \sum_{\substack{ux \in E(Q(G_1)), \\ u \in V_1, x \in V_1^*}} (d_{(G_1 * Q G_2)}(u, v) d_{(G_1 * Q G_2)}(x, v)) = \sum_{v \in V_2} \sum_{\substack{ux \in E(Q(G_1)), \\ u \in V_1, x \in V_1^*}} d_{Q(G_1)}(u) (d_{Q(G_1)}(x) + d_{G_2}(v)) \\
&= \sum_{v \in V_2} \sum_{\substack{ux \in E(Q(G_1)), \\ u \in V_1, x \in V_1^*}} d_{Q(G_1)}(u) d_{Q(G_1)}(x) + d_{G_2}(v) d_{Q(G_1)}(u) \\
&= \sum_{v \in V_2} \sum_{\substack{ux \in E(Q(G_1)), \\ u \in V_1, x \in V_1^*}} d_{G_1}(u) d_{Q(G_1)}(x) + \sum_{v \in V_2} \sum_{\substack{ux \in E(Q(G_1)), \\ u \in V_1, x \in V_1^*}} d_{G_1}(u) d_{G_2}(v) \\
&= |V_2| (F(G_1) + 2M_2(G_1)) + 2|E_2| M_1(G_1).
\end{aligned}$$

The second part is

$$\begin{aligned}
& \sum_{v \in V_2} \left(\sum_{\substack{ux \in E(Q(G_1)), \\ u, x \in V_1^*}} (d_{Q(G_1)}(u) + d_{G_2}(v)) (d_{Q(G_1)}(x) + d_{G_2}(v)) \right) \\
&= \sum_{v \in V_2} \sum_{\substack{ux \in E(Q(G_1)), \\ u, x \in V_1^*}} (d_{Q(G_1)}(u) d_{Q(G_1)}(x) + d_{G_2}(v) (d_{Q(G_1)}(u) + d_{Q(G_1)}(x)) + d_{G_2}(v)^2) \\
&= \sum_{v \in V_2} \left(\sum_{\substack{u_i u_j \in E_1, \\ u_j u_k \in E_1}} (d_{G_1}(u_i) + d_{G_1}(u_j)) (d_{G_1}(u_j) + d_{G_1}(u_k)) \right) \\
&\quad + \sum_{v \in V_2} d_{G_2}(v) \left(\sum_{\substack{u_i u_j \in E_1, \\ u_j u_k \in E_1}} (d_{G_1}(u_i) + d_{G_1}(u_j) + d_{G_1}(u_j) + d_{G_1}(u_k)) \right) + (|E(Q(G_1))| - 2|E_1|) M_1(G_2)
\end{aligned}$$

$$\begin{aligned}
&= |V_2| \left(\sum_{u_j \in V_1} C_{d_{G_1}(u_j)}^2 d_{G_1}(u_j)^2 + \sum_{u_i, u_j \in V_1} r_{ij} d_{G_1}(u_i) d_{G_1}(u_j) + \sum_{u_j \in V_1} (d_{G_1}(u_j) - 1) d_{G_1}(u_j) \sum_{\substack{u_i \in V_1, \\ u_i u_j \in E_1}} d_{G_1}(u_i) \right) \\
&+ 2|E_2| \left(2 \sum_{u_j \in V_1} C_{d_{G_1}(u_j)}^2 d_{G_1}(u_j) + \sum_{u_j \in V_1} (d_{G_1}(u_j) - 1) \sum_{\substack{u_i \in V_1, \\ u_i u_j \in E_1}} d_{G_1}(u_i) \right) + (|E(Q(G_1))| - 2|E_1|) M_1(G_2) \\
&= |V_2| \left(\frac{1}{2} \sum_{u_j \in V_1} (d_{G_1}(u_j)^4 - d_{G_1}(u_j)^3) + \sum_{u_i, u_j \in V_1} r_{ij} d_{G_1}(u_i) d_{G_1}(u_j) \right) \\
&\quad + |V_2| \left(\sum_{u_j \in V_1} d_{G_1}(u_j)^2 \sum_{\substack{u_i \in V_1, \\ u_i u_j \in E_1}} d_{G_1}(u_i) - 2M_2(G_1) \right) \\
&+ 2|E_2| \left(\sum_{u_j \in V_1} (d_{G_1}(u_j)^3 - d_{G_1}(u_j)^2) + \sum_{u_j \in V_1} (d_{G_1}(u_j) - 1) \sum_{\substack{u_i \in V_1, \\ u_i u_j \in E_1}} d_{G_1}(u_i) \right) + (|E(Q(G_1))| - 2|E_1|) M_1(G_2) \\
&= |V_2| \left(\frac{1}{2} M_4(G_1) - \frac{1}{2} F(G_1) + \sum_{u_i, u_j \in V_1} r_{ij} d_{G_1}(u_i) d_{G_1}(u_j) + \sum_{u_j \in V_1} d_{G_1}(u_j)^2 \sum_{\substack{u_i \in V_1, \\ u_i u_j \in E_1}} d_{G_1}(u_i) - 2M_2(G_1) \right) \\
&\quad + 2|E_2| (F(G_1) + 2M_2(G_1) - 2M_1(G_1)) + (|E(Q(G_1))| - 2|E_1|) M_1(G_2).
\end{aligned}$$

Here $u_i u_j$ is the edge corresponding to the vertex u and $u_j u_k$ is the edge corresponding to the vertex x , r_{ij} denotes the number of common vertices adjacent to both u_i and u_j . Thus we obtain

$$\begin{aligned}
M_2(G_1 *_Q G_2) &= |E_2| M_2(G_1) + |E_1| M_2(G_2) + M_2(G_1) M_2(G_2) + 2|E_2| M_1(G_1) \\
&\quad + \frac{1}{2} [|V_2| M_4(G_1) + (2|E_2| + |V_2|) F(G_1)] \\
&\quad + |V_2| \left(\sum_{u_i, u_j \in V_1} r_{ij} d_{G_1}(u_i) d_{G_1}(u_j) + \sum_{u_j \in V_1} d_{G_1}(u_j)^2 \sum_{\substack{u_i \in V_1, \\ u_i u_j \in E_1}} d_{G_1}(u_i) \right).
\end{aligned}$$

□

Theorem 4. Let G_1 and G_2 be two connected graphs, then

- (a) $M_1(G_1 *_T G_2) = 2|E_2| M_1(G_1) + |E_1| M_1(G_2) + 2|V_2| M_2(G_1)$
 $\quad + |V_2| F(G_1) + 4(|E(T(G_1))| - 3|E_1|) |E_2|,$
- (b) $M_2(G_1 *_T G_2) = 5|E_2| M_2(G_1) + (4|V_2| + |E_1|) M_2(G_2) + M_2(G_1) M_2(G_2) - 2|E_2| M_1(G_1)$
 $\quad + (|E(T(G_1))| - 3|E_1|) M_1(G_2) + \frac{1}{2} [|V_2| M_4(G_1) + (2|E_2| + |V_2|) F(G_1)]$
 $\quad + |V_2| \left(\sum_{u_i, u_j \in V_1} r_{ij} d_{G_1}(u_i) d_{G_1}(u_j) + \sum_{u_j \in V_1} d_{G_1}(u_j)^2 \sum_{u_i \in V_1, u_i u_j \in E_1} d_{G_1}(u_i) \right).$

where r_{ij} denotes the number of common vertices adjacent to both u_i, u_j .

P r o o f. We prove this theorem using Theorem 2 and Theorem 3. When $u \in V_1^*$ and $vy \in E_2$

$$\sum_{u \in V_1^*} \sum_{vy \in E_2} (d_{(G_1 *_T G_2)}(u, v) + d_{(G_1 *_T G_2)}(u, y)) = \sum_{u \in V_1^*} \sum_{vy \in E_2} (d_{(G_1 *_Q G_2)}(u, v) + d_{(G_1 *_Q G_2)}(u, y)).$$

From Theorem 3

$$\sum_{u \in V_1^*} \sum_{vy \in E_2} (d_{(G_1 * T G_2)}(u, v) + d_{(G_1 * T G_2)}(u, y)) = 2|E_2|M_1(G_1) + |E_1|M_1(G_2).$$

Also

$$\begin{aligned} & \sum_{v \in V_2} \sum_{ux \in E(T(G_1))} (d_{(G_1 * T G_2)}(u, v) + d_{(G_1 * T G_2)}(x, v)) \\ &= \sum_{v \in V_2} \sum_{\substack{ux \in E(T(G_1)), \\ u \in V_1, x \in V_1^*}} (d_{(G_1 * T G_2)}(u, v) + d_{(G_1 * T G_2)}(x, v)) \\ &+ \sum_{v \in V_2} \sum_{\substack{ux \in E(T(G_1)), \\ u, x \in V_1^*}} (d_{(G_1 * T G_2)}(u, v) + d_{(G_1 * T G_2)}(x, v)) \\ &+ \sum_{v \in V_2} \sum_{\substack{ux \in E(T(G_1)), \\ u, x \in V_1}} (d_{(G_1 * T G_2)}(u, v) + d_{(G_1 * T G_2)}(x, v)). \end{aligned}$$

Also from Theorem 2 and Theorem 3

$$\begin{aligned} & \sum_{v \in V_2} \sum_{ux \in E(T(G_1))} (d_{(G_1 * T G_2)}(u, v) + d_{(G_1 * T G_2)}(x, v)) \\ &= 4(|E(T(G_1))| - 3|E_1|)|E_2| + |V_2|(F(G_1) + 2M_2(G_1) - 2M_1(G_1)) + 2|V_2|M_1(G_1)). \end{aligned}$$

Thus,

$$\begin{aligned} M_1(G_1 * T G_2) &= 2|E_2|M_1(G_1) + |E_1|M_1(G_2) + 2|V_2|M_2(G_1) \\ &+ |V_2|F(G_1) + 4(|E(T(G_1))| - 3|E_1|)|E_2|. \end{aligned}$$

Similarly for M_2 , from Theorem 3

$$\begin{aligned} & \sum_{u \in V_1^*} \sum_{vy \in E_2} (d_{(G_1 * T G_2)}(u, v)d_{(G_1 * T G_2)}(u, y)) \\ &= |E_2|F(G_1) + |E_2|M_2(G_1) + M_2(G_1)M_2(G_2) + |E_1|M_2(G_2). \end{aligned}$$

The second part of the sum is

$$\begin{aligned} & \sum_{v \in V_2} \sum_{ux \in E(T(G_1))} (d_{(G_1 * T G_2)}(u, v)d_{(G_1 * T G_2)}(x, v)) = \sum_{v \in V_2} \sum_{\substack{ux \in E(T(G_1)), \\ u \in V_1, x \in V_1^*}} (d_{(G_1 * T G_2)}(u, v)d_{(G_1 * T G_2)}(x, v)) \\ &+ \sum_{v \in V_2} \sum_{\substack{ux \in E(T(G_1)), \\ u, x \in V_1^*}} (d_{(G_1 * T G_2)}(u, v)d_{(G_1 * T G_2)}(x, v)) \\ &+ \sum_{v \in V_2} \sum_{ux \in E(T(G_1)), u, x \in V_1} (d_{(G_1 * T G_2)}(u, v)d_{(G_1 * T G_2)}(x, v)). \end{aligned}$$

From Theorem 2 and Theorem 3 we get

$$\begin{aligned} & \sum_{v \in V_2} \sum_{ux \in E(T(G_1))} (d_{(G_1 * T G_2)}(u, v)d_{(G_1 * T G_2)}(x, v)) = |V_2|(F(G_1) + 2M_2(G_1)) + 2|E_2|M_1(G_1) \\ &+ |V_2| \left(\frac{1}{2}M_4(G_1) - \frac{1}{2}F(G_1) + \sum_{u_i, u_j \in V_1} r_{ij}d_{G_1}(u_i)d_{G_1}(u_j) + \sum_{u_j \in V_1} d_{G_1}(u_j)^2 \sum_{\substack{u_i \in V_1 \\ u_i u_j \in E_1}} d_{G_1}(u_i) - 2M_2(G_1) \right) \\ &+ 2|E_2|(F(G_1) + 2M_2(G_1) - 2M_1(G_1)) + (|E(Q(G_1))| - 2|E_1|)M_1(G_2) + 4|V_2|M_2(G_2), \end{aligned}$$

here r_{ij} denotes the number of common vertices adjacent to both u_i, u_j . Thus we obtain

$$\begin{aligned} M_2(G_1 *_T G_2) &= 5|E_2|M_2(G_1) + (4|V_2| + |E_1|)M_2(G_2) + M_2(G_1)M_2(G_2) - 2|E_2|M_1(G_1) \\ &\quad + (|E(T(G_1))| - 3|E_1|)M_1(G_2) + \frac{1}{2}[|V_2|M_4(G_1) + (2|E_2| + |V_2|)F(G_1)] \\ &\quad + |V_2|\left(\sum_{u_i, u_j \in V_1} r_{ij}d_{G_1}(u_i)d_{G_1}(u_j) + \sum_{u_j \in V_1} d_{G_1}(u_j)^2 \sum_{u_i \in V_1, u_i u_j \in E_1} d_{G_1}(u_i)\right). \end{aligned}$$

□

4. Applications with illustration

The above computational procedure can be used to find the respective indices for many classes of graphs very easily. As an illustration we provide the following.

Example 1. When $G_1 = P_n, G_2 = P_m, n, m > 3$, using the theorem, we easily obtain the following results

1. $M_1(P_n *_S P_m) = 20mn - 22m - 14n + 14,$
 $M_2(P_n *_S P_m) = 32mn - 40m - 24n + 38;$
2. $M_1(P_n *_R P_m) = 32mn - 40m - 14n + 14,$
 $M_2(P_n *_R P_m) = 64mn - 48m + 24n - 80;$
3. $M_1(P_n *_Q P_m) = 40mn - 64m - 22n + 30,$
 $M_2(P_n *_Q P_m) = 96mn - 184m + 18n + 134;$
4. $M_1(P_n *_T P_m) = 48mn - 82m - 22n + 30,$
 $M_2(P_n *_T P_m) = 136mn - 258m - 86n + 146.$

Let $\mathcal{T}_{n,m}$ denote the torus grid graph obtained from the cycle C_n and C_m . Using F^* sums, we can compute the Zagreb indices of torus grid graph $\mathcal{T}_{2n,m}$ since $\mathcal{T}_{2n,m} = C_n *_S C_m$.

Example 2. When $G_1 = C_n, G_2 = C_m, n, m > 3$, using the theorem, we easily obtain the following results

1. $M_1(C_n *_S C_m) = 20mn,$
 $M_2(C_n *_S C_m) = 32mn;$
2. $M_1(C_n *_R C_m) = 32mn,$
 $M_2(C_n *_R C_m) = 48mn;$
3. $M_1(C_n *_Q C_m) = 40mn,$
 $M_2(C_n *_Q C_m) = 96mn;$
4. $M_1(C_n *_T C_m) = 52mn,$
 $M_2(C_n *_T C_m) = 136mn.$

We can also find the Zagreb indices of some chemical structures using the expressions of F^* sums.

Example 3. Let $n \geq 3$ be an integer, then Zagreb indices of the zigzag polyhex nanotube $TUHC6[2n, 2]$

$$M_1(TUHC6[2n, 2]) = 26n,$$

$$M_2(TUHC6[2n, 2]) = 33n.$$

Since $TUHC6[2n, 2] = C_n *_S P_2$, then by Theorem 1.

Using F^* sums, we can also find the Zagreb indices of some classes of bridge graphs. Let v_1, v_2, \dots, v_n be vertices of graphs G_1, G_2, \dots, G_n respectively. The bridge graph using v_1, v_2, \dots, v_n is secured by joining the vertices v_i of G_i to v_{i+1} of G_{i+1} for $i = 1, 2, \dots, n-1$ and it is denoted by $B(G_1, G_2, \dots, G_n; v_1, v_2, \dots, v_n)$. If $G_i \cong G_{i+1} \cong G$ and $v_i = v_{i+1} = v$ for all $i = 1, 2, \dots, n$, then $B(G, G, \dots, G; v, v, \dots, v) = G_n(G, v)$. Let $B_n = G_n(P_3, v)$ where the degree $d(v) = 2$ and $T_{n,3} = G_n(C_3, v)$ [14] be two class of bridge graphs.

Example 4. Let $n \geq 2$ be an integer, then

$$M_1(B_n) = 18n - 14,$$

$$M_2(B_n) = 24n - 28;$$

$$M_1(T_{n,3}) = 24n - 14,$$

$$M_2(T_{n,3}) = 36n - 32.$$

Since $B_n = P_2 *_S P_n$ and $T_{n,3} = P_2 *_R P_n$ and by Theorem 1 and Theorem 2.

5. Summary and Conclusion

The F sum of graphs was a new sum defined by M. Eliasi, B. Taeri in [6], a lot of research has been done on this to compute various topological indices of this F sum. In this paper we have defined a similar new operation and computed the first and second Zagreb index of this sum. Computing other topological indices on these sums is an area which researchers may find helpful.

Acknowledgements

The authors are highly indebted to the anonymous referees for their valuable comments and suggestions which led to an improved presentation of the results.

REFERENCES

1. Alex L., Indulal G. Some degree based topological indices of a generalised F sums of graphs. *Electron. J. Math. Anal. Appl.*, 2021. Vol. 9, No. 1. P. 91–111.
2. Alex L., Indulal G. On the Wiener index of F_H sums of graphs. *J. Comput. Sci. Appl. Math.*, 2021. Vol. 3, No. 2. P. 37–57. DOI: [10.37418/jcsam.3.2.1](https://doi.org/10.37418/jcsam.3.2.1)
3. Balaban A. T., Motoc I., Bonchev D., Mekenyan O. Topological indices for structure-activity correlations. In: *Topics Curr. Chem., vol 114: Steric Effects in Drug Design*. Berlin, Heidelberg: Springer, 1983. P. 21–55. DOI: [10.1007/BFb0111212](https://doi.org/10.1007/BFb0111212)
4. Cvetković D. M., Doob M., Sachs H. *Spectra of Graphs: Theory and Application*. New York: Academic Press, 1980. 368 p.
5. Deng H., Sarala D., Ayyaswamy S. K., Balachandran S. The Zagreb indices of four operations on graphs. *Appl. Math. Comput.*, 2016. Vol. 275. P. 422–431. DOI: [10.1016/j.amc.2015.11.058](https://doi.org/10.1016/j.amc.2015.11.058)
6. Eliasi M., Taeri B. Four new sums of graphs and their Wiener indices. *Discrete Appl. Math.*, 2009. Vol. 157, No. 4. P. 794–803. DOI: [10.1016/j.dam.2008.07.001](https://doi.org/10.1016/j.dam.2008.07.001)
7. Furtula B., Gutman I. A forgotten topological index. *J. Math. Chem.*, 2015. Vol. 53. P. 1184–1190. DOI: [10.1007/s10910-015-0480-z](https://doi.org/10.1007/s10910-015-0480-z)
8. Gutman I. On the origin of two degree-based topological indices. *Bull. Acad. Serbe Sci. Arts Cl. Sci. Math. Natur.*, 2014, Vol. 146. P. 39–52.
9. Gutman I., Das K. C. The first Zagreb index 30 years after. *MATCH Commun. Math. Comput. Chem.*, 2004. Vol. 50. P. 83–92.

10. Gutman I., Milovanović E., Milovanović I. Beyond the Zagreb indices. *AKCE Int. J. Graphs and Combinatorics*, 2018. DOI: [10.1016/j.akcej.2018.05.002](https://doi.org/10.1016/j.akcej.2018.05.002)
11. Gutman I., Trinajstić N. Graph theory and molecular orbitals. Total φ -electron energy of alternant hydrocarbons. *Chem. Phys. Lett.*, 1972, Vol. 17, No. 4. P. 535–538. DOI: [10.1016/0009-2614\(72\)85099-1](https://doi.org/10.1016/0009-2614(72)85099-1)
12. Gutman I., Ruščić B., N. Trinajstić, Wilcox C.F. Graph theory and molecular orbitals. XII. Acyclic polyenes. *J. Chem. Phys.*, 1975. Vol. 62, No. 9. P. 3399–3405.
13. Gutman I. An exceptional property of the first Zagreb index. *MATCH Commun. Math. Comput. Chem.*, 2014. Vol. 72. P. 733–740.
14. Imran M., Akhter S., Iqbal Z. Edge Mostar index of chemical structures and nanostructures using graph operations. *Int. J. Quantum Chem.*, 2020. Vol. 120, No. 15. Art. no. e26259. DOI: [10.1002/qua.26259](https://doi.org/10.1002/qua.26259)
15. Indulal G., Alex L., Gutman I. On graphs preserving PI index upon edge removal. *J. Math. Chem.*, 2021. Vol. 59. P. 1603–1609. DOI: [10.1007/s10910-021-01255-1](https://doi.org/10.1007/s10910-021-01255-1)
16. Khalifeh M.H., Yousefi-Azari H., Ashrafi A.R. The first and second Zagreb indices of some graph operations. *Discrete Appl. Math.*, 2009. Vol. 157. P. 804–811. DOI: [10.1016/j.dam.2008.06.015](https://doi.org/10.1016/j.dam.2008.06.015)
17. Li X., Zhao H. Trees with the first three smallest and largest generalized topological indices. *MATCH Commun. Math. Comput. Chem.*, 2004. Vol. 50. P. 57–62.
18. Li X., Zheng J. A unified approach to the extremal trees for different indices. *MATCH Commun. Math. Comput. Chem.*, 2005. Vol. 54, P. 195–208.
19. Nikolić S., Kovačević G., Miličević A., Trinajstić N. The Zagreb indices 30 years after. *Croat. Chem. Acta.*, 2003. Vol. 76, No. 2. P. 113–124.
20. Stevanović D. *Mathematical Properties of Zagreb Indices*. Beograd: Akademska misao, 2014. (in Serbian)
21. Wiener H. Structural determination of paraffin boiling points. *J. Am. Chem. Soc.*, 1947. Vol. 69. P. 17–20. DOI: [10.1021/ja01193a005](https://doi.org/10.1021/ja01193a005)

SOME TRIGONOMETRIC SIMILARITY MEASURES OF COMPLEX FUZZY SETS WITH APPLICATION

Md. Yasin Ali

Faculty of Science and Engineering,
University of Information Technology and Sciences,
Dhaka-1212, Bangladesh

ali.mdyasin56@gmail.com

Abstract: Similarity measures of fuzzy sets are applied to compare the closeness among fuzzy sets. These measures have numerous applications in pattern recognition, image processing, texture synthesis, medical diagnosis, etc. However, in many cases of pattern recognition, digital image processing, signal processing, and so forth, the similarity measures of the fuzzy sets are not appropriate due to the presence of dual information of an object, such as amplitude term and phase term. In these cases, similarity measures of complex fuzzy sets are the most suitable for measuring proximity between objects with two-dimensional information. In the present paper, we propose some trigonometric similarity measures of the complex fuzzy sets involving similarity measures based on the sine, tangent, cosine, and cotangent functions. Furthermore, in many situations in real life, the weight of an attribute plays an important role in making the right decisions using similarity measures. So in this paper, we also consider the weighted trigonometric similarity measures of the complex fuzzy sets, namely, the weighted similarity measures based on the sine, tangent, cosine, and cotangent functions. Some properties of the similarity measures and the weighted similarity measures are discussed. We also apply our proposed methods to the pattern recognition problem and compare them with existing methods to show the validity and effectiveness of our proposed methods.

Keywords: Complex fuzzy set, Similarity measures, Pattern recognition.

1. Introduction

The fuzzy set theory introduced by L.A. Zadeh [34] has been revealed to be a valuable apparatus for designating situations in which the data are imprecise or vague. Fuzzy sets (FSs) describe such cases by assigning a degree to which a particular object belongs to a set. It is a robust system where no precise inputs are required; as a result, it has been applied in numerous branches of science and engineering with great success. However, in real life, there is a lot of uncertain data that cannot be described by fuzzy sets due to the presence of dual information about the object, such as the amplitude term and the phase term. To describe such uncertain data, Ramot et al. [25] introduced the concept of complex fuzzy set (CFS), in which the membership function is characterized by a complex number in the polar form $r_A(x)e^{i\omega_A(x)}$ belonging to the unit circle of the complex plane, where $r_A(x)$ and $e^{i\omega_A(x)}$ denote the amplitude term and the phase term of an element $x \in A \subseteq X$, respectively. The amplitude term consistent with the membership degree gives the extent of belonging of an object to a CFS, and the phase term allied with the membership degree provides supplementary data associated with periodicity. The phase term is a unique parameter of the membership degree and is the crucial difference between a traditional FS and a CFS. Due to the presence of the phase term in a CFS, the uncertainty of an object can be described more accurately than by an FS. As a result, the concept of CFSs has been applied by a host of researchers in many areas of our real-life situations, such as image processing [19], signal processing [16, 25, 35], decision making [1, 3, 4, 21, 22], and so on by using different mathematical tools, such as distance measures, aggregation operations, entropy measures, and so forth.

On the other hand, the similarity measure is a core method to see how two objects are related together. The similarity measures between the fuzzy sets are significant topics in fuzzy mathematics which have obtained much attention for their wide applications in various fields, such as pattern recognition [15], decision making [27, 28], image processing [29], clustering [7, 10, 13], approximate reasoning [26, 33], and many other fields (see [8, 32]). The theoretical aspects of the similarity measures of the FSs are also studied by a host of researchers (see [2, 5, 6, 9, 11, 12, 17, 18, 23, 24, 30, 31, 36]).

However, if the data sets are related to a two-dimensional aspect, then the similarity measures of the fuzzy sets fail to compare the proximity among the data sets. To overcome these situations, Guo et al. [14] introduced the cosine similarity measure of complex fuzzy sets and applied it to measure the robustness of the complex fuzzy connectives and the complex fuzzy inference. Moreover, trigonometric similarity measures are important in solving numerous complicated problems in pattern recognition, medical diagnosis, signal processing, etc. But still now, as far as known from the literature, there are no trigonometric similarity measures for CFSs. So, in this paper, we introduce some trigonometric similarity measures for CFSs. Also, the weighted trigonometric similarity measures for CFSs are established. Finally, an application in the pattern recognition problem is illustrated by using our proposed similarity measures.

The paper is organized as follows. In Section 2, we describe some basic properties of CFSs. In Section 3, we introduce some trigonometric similarity measures involving similarity measures based on the sine, tangent, cosine, and cotangent functions. We also define weighted trigonometric similarity measures based on the sine, tangent, cosine, and cotangent functions. In Section 4, a practical example illustrates using these similarity measures and weighted similarity measures. The comparison studies with existing methods and advantages of our proposed methods are also described in Section 4. Finally, a concluding remark is given.

2. Preliminaries

In this section, we describe some basic concepts of CFSs from [25], which are essential to the rest of the paper.

2.1. Complex fuzzy set

A complex fuzzy set defined on a universal set X is characterized by a membership function $\mu_A(x)$ that assigns a complex-valued grade of membership in A to any element $x \in X$. By definition, all values of $\mu_A(x)$ lie within the unit circle in the complex plane and are expressed in the form $r_A(x) \cdot e^{i\omega_A(x)}$, where $i = \sqrt{-1}$, $r_A(x)$ and $\omega_A(x)$ are both real-valued, $r_A(x) \in [0, 1]$, and $\omega_A(x) \in [0, 2\pi]$. A complex fuzzy set may be represented as the set of ordered pairs

$$A = \{(x, \mu_A(x)) : x \in X\} = \{(x, r_A(x) \cdot e^{i\omega_A(x)}) : x \in X\}.$$

For every two CFSs

$$A = \{(x, r_A(x) \cdot e^{i\omega_A(x)})\} \quad \text{and} \quad B = \{(x_j, r_B(x) \cdot e^{i\omega_B(x)})\},$$

$A \subseteq B$ if $r_A(x) \leq r_B(x)$ and $\omega_A(x) \leq \omega_B(x)$.

3. Some trigonometric similarity measures of complex fuzzy sets

In this section, we propose similarity measures based on the sine, tangent, cosine, and cotangent functions of CFSs. In many decision-making problems, sometimes we need the weight of attributes

to describe precisely any situation. These weights of attributes play an important role in making decisions properly. As a result, we consider the weighted similarity measures based on the sine, tangent, cosine, and cotangent functions of CFSs. Some properties of these similarity measures and weighted similarities are also described.

3.1. Similarity measures based on the sine function

Let

$$A = \{(x_j, r_A(x_j) \cdot e^{i\omega_A(x_j)})\}, \quad B = \{(x_j, r_B(x_j) \cdot e^{i\omega_B(x_j)})\}$$

be two CFSs in the universe of discourse $X = \{x_1, x_2, \dots, x_n\}$, $x_j \in X$. Then the similarity measures based on the sine function between A and B can be defined as follows:

$$SSF^1(A, B) = 1 - \frac{1}{n} \sum_{j=i}^n \sin \left\{ \frac{\pi}{2} [|r_A(x_j) - r_B(x_j)| \vee \frac{1}{2\pi} (|\omega_A(x_j) - \omega_B(x_j)|)] \right\},$$

$$SSF^2(A, B) = 1 - \frac{1}{n} \sum_{j=i}^n \sin \left\{ \frac{\pi}{4} [|r_A(x_j) - r_B(x_j)| + \frac{1}{2\pi} (|\omega_A(x_j) - \omega_B(x_j)|)] \right\},$$

where the symbol \vee denotes the maximum operator.

Proposition 1. For two CFSs A and B in $X = \{x_1, x_2, \dots, x_n\}$, the similarity measures $SSF^k(A, B)$, $k = 1, 2$, have the following properties:

- (1) $0 \leq SSF^k(A, B) \leq 1$;
- (2) $SSF^k(A, B) = SSF^k(B, A)$;
- (3) $SSF^k(A, B) = 1$ if and only if $A = B$;
- (4) if C is a CFS in X and $A \subseteq B \subseteq C$, then $SSF^k(A, B) \geq SSF^k(A, C)$ and $SSF^k(B, C) \geq SSF^k(A, C)$.

P r o o f. (1) It is known that the sine function monotonically increases in the interval $[0, \pi/2]$ and takes values from $[0, 1]$. Therefore, we have $0 \leq SSF^k(A, B) \leq 1$.

(2) This property is obvious.

(3) If $A = B$, then $r_A(x_j) = r_B(x_j)$ and $\omega_A(x_i) = \omega_B(x_i)$ for $j = 1, 2, \dots, n$. Therefore, $SSF^k(A, B) = 1$.

(4) If $A \subseteq B \subseteq C$, then $r_A(x_j) \leq r_B(x_j) \leq r_C(x_j)$ and $\omega_A(x_j) \leq \omega_B(x_j) \leq \omega_C(x_j)$ for $j = 1, 2, \dots, n$. Then we have

$$\begin{aligned} |r_A(x_j) - r_B(x_j)| &\leq |r_A(x_j) - r_C(x_j)|, \\ |r_B(x_j) - r_C(x_j)| &\leq |r_A(x_j) - r_C(x_j)|, \end{aligned}$$

and

$$\begin{aligned} |\omega_A(x_j) - \omega_B(x_j)| &\leq |\omega_A(x_j) - \omega_C(x_j)|, \\ |\omega_B(x_j) - \omega_C(x_j)| &\leq |\omega_A(x_j) - \omega_C(x_j)|. \end{aligned}$$

Hence,

$$\begin{aligned} SSF^2(A, B) &= 1 - \frac{1}{n} \sum_{j=i}^n \sin \left\{ \frac{\pi}{4} [|r_A(x_j) - r_B(x_j)| + \frac{1}{2\pi} (|\omega_A(x_j) - \omega_B(x_j)|)] \right\} \\ &\geq 1 - \frac{1}{n} \sum_{j=i}^n \sin \left\{ \frac{\pi}{4} [|r_A(x_j) - r_C(x_j)| + \frac{1}{2\pi} (|\omega_A(x_j) - \omega_C(x_j)|)] \right\} = SSF^2(A, C). \end{aligned}$$

Similarly, we can prove that $SSF^2(B, C) \geq SSF^2(A, C)$ as well as $SSF^1(A, B) \geq SSF^1(A, C)$ and $SSF^1(B, C) \geq SSF^1(A, C)$. Hence, $SSF^k(A, B) \geq SSF^k(A, C)$ and $SSF^k(B, C) \geq SSF^k(A, C)$. \square

Taking a real-valued weight of x_j , we propose to consider the following weighted similarity measures based on the sine function between CFSs A and B :

$$WSSF^1(A, B) = 1 - \frac{1}{n} \sum_{j=i}^n \rho_j \sin \left\{ \frac{\pi}{2} [|r_A(x_j) - r_B(x_j)| \vee \frac{1}{2\pi} (|\omega_A(x_j) - \omega_B(x_j)|)] \right\},$$

$$WSSF^2(A, B) = 1 - \frac{1}{n} \sum_{j=i}^n \rho_j \sin \left\{ \frac{\pi}{4} [|r_A(x_j) - r_B(x_j)| + \frac{1}{2\pi} (|\omega_A(x_j) - \omega_B(x_j)|)] \right\},$$

where $\rho = (\rho_1, \rho_2, \dots, \rho_n)^T$ and ρ_j is the weight vector of x_j ($j = 1, 2, \dots, n$), $\rho_j \in [0, 1]$, and $\sum_{j=1}^n \rho_j = 1$. If we take $\rho_j = 1/n$, $j = 1, 2, \dots, n$, then $WSSF^k(A, B) = SSF^k(A, B)$, $k = 1, 2$.

Proposition 2. For two CFSs A and B in $X = \{x_1, x_2, \dots, x_n\}$, the weighted similarity measures based on the sine function $SSF^k(A, B)$, $k = 1, 2$, have the following properties:

- (1) $0 \leq WSSF^k(A, B) \leq 1$;
- (2) $WSSF^k(A, B) = WSSF^k(B, A)$;
- (3) $WSSF^k(A, B) = 1$ if and only if $A = B$;
- (4) if C is a CFS in X and $A \subseteq B \subseteq C$, then $WSSF^k(A, B) \geq WSSF^k(A, C)$ and $WSSF^k(B, C) \geq WSSF^k(A, C)$.

P r o o f. Similarly to the previous proof methods, we can prove the above four properties. \square

3.2. Similarity measures based on the tangent function

Let

$$A = \{(x_j, r_A(x_j) \cdot e^{i\omega_A(x_j)})\}, \quad B = \{(x_j, r_B(x_j) \cdot e^{i\omega_B(x_j)})\}$$

be two CFSs in $X = \{x_1, x_2, \dots, x_n\}$, $x_j \in X$. Then the similarity measures based on the tangent function between A and B are defined as follows:

$$STF^1(A, B) = 1 - \frac{1}{n} \sum_{j=i}^n \tan \left\{ \frac{\pi}{4} [|r_A(x_j) - r_B(x_j)| \vee \frac{1}{2\pi} (|\omega_A(x_j) - \omega_B(x_j)|)] \right\},$$

$$STF^2(A, B) = 1 - \frac{1}{n} \sum_{j=i}^n \tan \left\{ \frac{\pi}{8} [|r_A(x_j) - r_B(x_j)| + \frac{1}{2\pi} (|\omega_A(x_j) - \omega_B(x_j)|)] \right\}.$$

Proposition 3. For two CFSs A and B in $X = \{x_1, x_2, \dots, x_n\}$, the similarity measures $STF^k(A, B)$, $k = 1, 2$, have the following properties:

- (1) $0 \leq STF^k(A, B) \leq 1$;
- (2) $STF^k(A, B) = STF^k(B, A)$;
- (3) $STF^k(A, B) = 1$ if and only if $A = B$;

- (4) if C is a CFS in X and $A \subseteq B \subseteq C$, then $STF^k(A, B) \geq STF^k(A, C)$ and $STF^k(B, C) \geq STF^k(A, C)$.

P r o o f. The proofs are similar to the proofs for the similarity measures based on the sine function. \square

Taking a real valued weight of x_j , we propose to consider the following weighted similarity measures based on the tangent function between CFSs A and B :

$$WSTF^1(A, B) = 1 - \frac{1}{n} \sum_{j=i}^n \rho_j \sin \left\{ \frac{\pi}{2} [|r_A(x_j) - r_B(x_j)| \vee \frac{1}{2\pi} (|\omega_A(x_j) - \omega_B(x_j)|)] \right\},$$

$$WSTF^2(A, B) = 1 - \frac{1}{n} \sum_{j=i}^n \rho_j \sin \left\{ \frac{\pi}{4} [|r_A(x_j) - r_B(x_j)| + \frac{1}{2\pi} (|\omega_A(x_j) - \omega_B(x_j)|)] \right\},$$

where $\rho = (\rho_1, \rho_2, \dots, \rho_n)^T$ and ρ_j is the weight vector of x_j ($j = 1, 2, \dots, n$), $\rho_j \in [0, 1]$, $\sum_{j=1}^n \rho_j = 1$. If we take $\rho_j = 1/n$, $j = 1, 2, \dots, n$, then $WSTF^k(A, B) = STF^k(A, B)$, $k = 1, 2$.

Proposition 4. For two CFSs A and B in $X = \{x_1, x_2, \dots, x_n\}$, the weighted similarity measures based on the tangent function $WTSF^k(A, B)$, $k = 1, 2$, have the following properties:

- (1) $0 \leq WSTF^k(A, B) \leq 1$;
- (2) $WSTF^k(A, B) = WSTF^k(B, A)$;
- (3) $WSTF^k(A, B) = 1$ if and only if $A = B$;
- (4) if C is a CFS in X and $A \subseteq B \subseteq C$, then $WSTF^k(A, B) \geq WSTF^k(A, C)$ and $WSTF^k(B, C) \geq WSTF^k(A, C)$.

P r o o f. The proofs are similar to the proofs for the similarity measures based on the sine function. \square

3.3. Similarity measures based on the cosine function

Let

$$A = \{(x_j, r_A(x_j) \cdot e^{i\omega_A(x_j)})\}, \quad B = \{(x_j, r_B(x_j) \cdot e^{i\omega_B(x_j)})\}$$

be two CFSs in $X = \{x_1, x_2, \dots, x_n\}$, $x_j \in X$. We define two similarity measures between A and B based on the cosine function as follows:

$$SCF^1 = \frac{1}{n} \sum_{j=i}^n \cos \left\{ \frac{\pi}{2} [|r_A(x_j) - r_B(x_j)| \vee \frac{1}{2\pi} (|\omega_A(x_j) - \omega_B(x_j)|)] \right\},$$

$$SCF^2 = \frac{1}{n} \sum_{j=i}^n \cos \left\{ \frac{\pi}{4} [|r_A(x_j) - r_B(x_j)| + \frac{1}{2\pi} (|\omega_A(x_j) - \omega_B(x_j)|)] \right\}.$$

Proposition 5. For two CFSs A and B in $X = \{x_1, x_2, \dots, x_n\}$, the similarity measures $SCF^k(A, B)$, $k = 1, 2$, have the following properties:

- (1) $0 \leq SCF^k(A, B) \leq 1$;

- (2) $SCF^k(A, B) = SCF^k(B, A)$;
- (3) $SCF^k(A, B) = 1$ if and only if $A = B$;
- (4) if C is a CFS in X and $A \subseteq B \subseteq C$, then $SCF^k(A, C) \leq SCF^k(A, B)$ and $SCF^k(A, C) \leq SCF^k(B, C)$.

P r o o f. The proofs of properties (1)–(3) are trivial. Let us prove property (4).

If $A \subseteq B \subseteq C$, then $r_A(x_j) \leq r_B(x_j) \leq r_C(x_j)$ and $\omega_A(x_j) \leq \omega_B(x_j) \leq \omega_C(x_j)$ for $j = 1, 2, \dots, n$. Then, we have

$$\begin{aligned} |r_A(x_j) - r_B(x_j)| &\leq |r_A(x_j) - r_C(x_j)|, \\ |r_B(x_j) - r_C(x_j)| &\leq |r_A(x_j) - r_C(x_j)|, \end{aligned}$$

and

$$\begin{aligned} |\omega_A(x_j) - \omega_B(x_j)| &\leq |\omega_A(x_j) - \omega_C(x_j)|, \\ |\omega_B(x_j) - \omega_C(x_j)| &\leq |\omega_A(x_j) - \omega_C(x_j)|. \end{aligned}$$

Hence, $SCF^k(A, C) \leq SCF^k(A, B)$ and $SCF^k(A, C) \leq SCF^k(B, C)$ for $k = 1, 2$. □

Taking a real weight of x_j , we define the weighted similarity measures based on the cosine function as follows:

$$\begin{aligned} WSCF^1 &= \sum_{j=i}^n \rho_j \cos \left\{ \frac{\pi}{2} [|r_A(x_j) - r_B(x_j)| \vee \frac{1}{2\pi} (|\omega_A(x_j) - \omega_B(x_j)|)] \right\}, \\ WSCF^2 &= \sum_{j=i}^n \rho_j \cos \left\{ \frac{\pi}{4} [|r_A(x_j) - r_B(x_j)| + \frac{1}{2\pi} (|\omega_A(x_j) - \omega_B(x_j)|)] \right\}, \end{aligned}$$

where $\rho = (\rho_1, \rho_2, \dots, \rho_n)^T$ and ρ_j is the weight vector of x_j ($j = 1, 2, \dots, n$), $\rho_j \in [0, 1]$, $\sum_{j=1}^n \rho_j = 1$. If we take $\rho_j = 1/n$, $j = 1, 2, \dots, n$, then $WSCF^k(A, B) = SCF^k(A, B)$, $k = 1, 2$.

It is clear that the weighted similarity measures based on the cosine function between CFSs A and B also satisfy the following statement.

Proposition 6. For two CFSs A and B in $X = \{x_1, x_2, \dots, x_n\}$, the similarity measures $WSCF^k(A, B)$, $k = 1, 2$, have the following properties:

- (1) $0 \leq WSCF^k(A, B) \leq 1$;
- (2) $WSCF^k(A, B) = WSCF^k(B, A)$;
- (3) $WSCF^k(A, B) = 1$ if and only if $A = B$;
- (4) if C is a CFS in X and $A \subseteq B \subseteq C$, then $WSCF^k(A, C) \leq WSCF^k(A, B)$ and $WSCF^k(A, C) \leq WSCF^k(B, C)$.

We can prove (1)–(4) using methods similar to the above proofs.

3.4. Similarity measures based on the cotangent function

For any two CFSs A and B , the similarity measure between A and B based on the cotangent function is defined as follows:

$$SCTF^1 = \frac{1}{n} \sum_{j=i}^n \cot \left[\frac{\pi}{4} + \frac{\pi}{4} (|r_A(x_j) - r_B(x_j)| \vee \frac{1}{2\pi} (|\omega_A(x_j) - \omega_B(x_j)|)) \right].$$

Taking a real weight of x_j , we define the weighted similarity measure based on the cotangent function between two CFSs A and B as follows:

$$WSCTF^1 = \sum_{j=i}^n \rho_j \cot \left[\frac{\pi}{4} + \frac{\pi}{4} (|r_A(x_j) - r_B(x_j)| \vee \frac{1}{2\pi} (|\omega_A(x_j) - \omega_B(x_j)|)) \right],$$

where $\rho_j = (\rho_1, \rho_2, \dots, \rho_n)^T$ and ρ_j is the weight vector of x_j ($j = 1, 2, \dots, n$), $\rho_j \in [0, 1]$, $\sum_{j=1}^n \rho_j = 1$. If we take $\rho_j = 1/n$, $j = 1, 2, \dots, n$, then $WSCTF^1(A, B) = SCTF^1(A, B)$.

4. Application of the proposed similarity measures in the pattern recognition problem

4.1. Application in pattern recognition

Pattern recognition is one of the most essential decision-making skills in problems of choice. It consists in finding an appropriate pattern from some unknown patterns. Pattern recognition with fuzzy data is becoming increasingly popular and important in research in medicine, engineering, computer science, psychology, and physiology, among others. However, in many cases of pattern recognition, such as digital images, speech, audio signals, voice, and language, among others, we face some problems due to the dual characteristics of an element. In this case, pattern recognition with complex fuzzy data is more suitable for describing such situations. In this section, we describe the problem of pattern recognition using our proposed similarity measures.

In general, we can formulate the pattern recognition problem in complex fuzzy sets as follows.

Problem Formulation. Let

$$B = \{(x_j, r_B(x_j) \cdot e^{i\omega_B(x_j)}) : x_j \in X, j = 1, 2, \dots, n\}$$

be an ideal pattern characterized by a complex fuzzy set in $X = \{x_1, x_2, \dots, x_n\}$. Let $\{A_1, A_2, \dots, A_m\}$ be some sample patterns characterized by complex fuzzy sets in $X = \{x_1, x_2, \dots, x_n\}$ as follows:

$$A_k = \{(x_j, r_{A_k}(x_j) \cdot e^{i\omega_{A_k}(x_j)}) : x_j \in X, j = 1, 2, \dots, n\}, \quad k = 1, 2, \dots, m.$$

Aim. Determine which sample pattern is close to ideal.

Solution. The sample patterns A_k , $k = 1, 2, \dots, m$, should be close to the ideal pattern B , which has the maximum similarity.

Now, we illustrate the performance of our proposed similarity measures with the help of a practical example. First, we describe our proposed unweighted similarity measures of an element of the universe of discourse. Second, we depict the weighted similarity measures.

Table 1. The representation of sample signals and an ideal signal by complex fuzzy sets.

	A_1	A_2	A_3	A_4	B
x_1	$0.5e^{i2\pi(0.3)}$	$0.8e^{i2\pi(0.2)}$	$0.6e^{i2\pi(0.4)}$	$0.7e^{i2\pi(0.6)}$	$0.8e^{i2\pi(0.9)}$
x_2	$0.4e^{i2\pi(0.5)}$	$0.7e^{i2\pi(0.4)}$	$0.7e^{i2\pi(0.6)}$	$0.1e^{i2\pi(0.2)}$	$0.6e^{i2\pi(0.5)}$
x_3	$0.2e^{i2\pi(0.1)}$	$0.1e^{i2\pi(0.4)}$	$0.5e^{i2\pi(0.6)}$	$0.9e^{i2\pi(0.2)}$	$0.6e^{i2\pi(0.3)}$

Table 2. The similarity measures between the sample signals and the ideal signal.

	(A_1, B)	(A_2, B)	(A_3, B)	(A_4, B)
$SSF^1(A_j, B)$	0.4316	0.4153	0.5610	0.4618
$SSF^2(A_j, B)$	0.5802	0.6225	0.7685	0.7169
$STF^1(A_j, B)$	0.6692	0.6316	0.7558	0.7020
$STF^2(A_j, B)$	0.7731	0.8056	0.8827	0.8180
$SCF^1(A_j, B)$	0.7828	0.7165	0.8620	0.8298
$SCF^2(A_j, B)$	0.8798	0.9105	0.9644	0.9562
$SCTF^1(A_j, B)$	0.5210	0.5035	0.6277	0.5473
$SCTF^2(A_j, B)$	0.6433	0.6763	0.7142	0.6549

Example 1. In this example, we practice our proposed similarity measures in audio signal processing. Suppose we have four sample audio signals $A = \{A_1, A_2, A_3, A_4\}$ and an ideal audio signal B that are characterized by complex fuzzy sets given in Table 1. Here $X = \{x_1, x_2, x_3\}$ represents different points on the signals and $r_{A_k}(x_j)$ ($j = 1, 2, 3, k = 1, 2, 3, 4$) and $r_B(x_j)$ ($j = 1, 2, 3$) represent the frequency of the sample signals and the ideal signal, respectively. The terms $\omega_{A_k}(x_j)$ ($j = 1, 2, 3, k = 1, 2, 3, 4$) and $\omega_B(x_j)$ ($j = 1, 2, 3$) represent the amplitude of the sample signals and the ideal signal, respectively. We aim to detect which sample signal is close to the ideal signal. To determine this, we use our proposed similarity measures. The results are given in Table 2. From the numerical results in Table 2, we observe that the signal A_3 is the closest to the signal B .

Again, we consider, the real valued weight vector of $x_j(j = 1, 2, 3)$ is $\rho = (0.30, 0.34, 0.36)^T$. Then by using table 1 and methods of weighted similarity measures of complex fuzzy sets, we obtain the results of weighted similarity measures between sample audio signals and ideal audio signal given in Table 3. From the numerical results in Table 3, we also observe that the signal A_3 is the closest to the signal B .

4.2. Comparison studies

As known from the literature, there is only a similarity measure, namely the cosine similarity measure [14], for CFSs, in which the range of similarity measurement value is from -1 to 1 . However, the similarity measurement value in our proposed methods ranges from 0 to 1 . So, for comparing the performance of our proposed methods, we consider some existing distance methods of CFSs proposed in [1, 20].

1. Applying the distance measure denoted by d_1 and using equation (4) from [1], we get the

Table 3. The weighted similarity measures between the sample signals and the ideal signal.

	(A_1, B)	(A_2, B)	(A_3, B)	(A_4, B)
$WSSF^1(A_j, B)$	0.4408	0.4251	0.5714	0.4601
$WSSF^2(A_j, B)$	0.5887	0.6268	0.7745	0.7159
$WSTF^1(A_j, B)$	0.6765	0.6404	0.7626	0.7008
$WSTF^2(A_j, B)$	0.7787	0.8079	0.8858	0.8144
$WSCF^1(A_j, B)$	0.7911	0.7262	0.8688	0.8286
$WSCF^2(A_j, B)$	0.8848	0.9124	0.9662	0.9559
$WSCTF^1(A_j, B)$	0.5286	0.5122	0.6359	0.5459
$WSCTF^2(A_j, B)$	0.6500	0.6797	0.7206	0.6534

following measurement value for each sample signal $\{A_1, A_2, \dots, A_m\}$ compared with the ideal signal B :

$$d_1(A_1, B) = 0.85, \quad d_1(A_2, B) = 0.75, \quad d_1(A_3, B) = 0.65, \quad d_1(A_4, B) = 0.8.$$

The minimum value of $d_1(A_j, B)$ is considered the best alternative. Since the measurement value of A_3 is the minimum among all these values, we conclude that A_3 is the closest to B .

- Utilizing the complex fuzzy weighted discrimination measures denoted by wd_1 as defined in [20], we get the following fuzzy measurement values by using Table 1 and the real-valued weight vector $\rho = (0.30, 0.34, 0.36)^T$ of $x_j (j = 1, 2, 3)$:

$$wd_1(A_1, B) = 0.24, \quad wd_1(A_2, B) = 0.27, \quad wd_1(A_3, B) = 0.15, \quad wd_1(A_4, B) = 0.19.$$

In this case, the minimum value of $wd_1(A_j, B)$ is also considered the best alternative. Since the measurement value of A_3 is the minimum among all these values, we again conclude that A_3 is the closest to B .

4.3. Advantages of our proposed methods

From the study of existing literature and our proposed methods, we address the following advantages of our proposed methods to apply in different branches of science and engineering.

- A CFS is an extension of FS considering two-dimensional information, such as the amplitude term and the phase term in a single element, whereas a real FS contains only the amplitude term in a single element. So the primary advantage of our proposed methods is capturing more information about an element when uncertainty arises in the case of decision-making, pattern recognition, image processing, signal processing, audio recognition, and others.
- It is disclosed from our study that some trigonometric similarity measures under the CFSs are particular forms of trigonometric similarity measures of real FSs, so we can use these similarity measures to solve many problems where a one-dimensional term presents in a single element by taking the phase term zero.

5. Conclusion

In our present study, an endeavor has been taken to develop some trigonometric similarity measures under the CFSs environment. Different kinds of similarity measures have been defined

in the FS environment where the membership degree of an element is a subset of real numbers. But in our proposed methods, the membership degree of an element is taken as a two-dimensional value which enables describing the uncertainty of an element more precisely. On the other hand, in the existing cosine similarity measure of CFS, which was introduced in [14], the range of similarity measurement values was taken from -1 to 1 , but the similarity measurement value should range from 0 till 1 . In our proposed methods, we also develop this limitation. In the future, we will extend our methods to an interval-valued complex fuzzy set, complex intuitionistic fuzzy set, complex Pythagorean fuzzy set, complex picture fuzzy set, and so forth. Also, other similarity measures for CFSs will be considered.

REFERENCES

1. Alkouri A.U.M., Salleh A.R. Linguistic variables, hedges and several distances on complex fuzzy sets. *J. Intell. Fuzzy Syst.*, 2014. Vol. 26, No. 5. P. 2527–2535. DOI: [10.3233/IFS-130923](https://doi.org/10.3233/IFS-130923)
2. Balopoulos V., Hatzimichailidis A. G., Papadopoulos B. K. Distance and similarity measures for fuzzy operators. *Inform. Sci.*, 2007. Vol. 177, No. 11. P. 2336–2348. DOI: [10.1016/j.ins.2007.01.005](https://doi.org/10.1016/j.ins.2007.01.005)
3. Bi L., Dai S., Hu B. Complex fuzzy geometric aggregation operators. *Symmetry*, 2018. Vol. 10, No. 7. Art. no. 251. DOI: [10.3390/sym10070251](https://doi.org/10.3390/sym10070251)
4. Bi L. et al. Complex fuzzy arithmetic aggregation operators. *J. Intell. Fuzzy Syst.*, 2019. Vol. 36, No. 3. P. 2765–2771. DOI: [10.3233/JIFS-18568](https://doi.org/10.3233/JIFS-18568)
5. Bosteels K., Kerre E.E. A triparametric family of cardinality-based fuzzy similarity measures. *Fuzzy Sets and Systems*, 2007. Vol. 158, No. 22. P. 2466–2479. DOI: [10.1016/j.fss.2007.05.006](https://doi.org/10.1016/j.fss.2007.05.006)
6. Bouchon-Meunier B., Coletti G., Lesot M.-J., Rifqi M. Towards a conscious choice of a fuzzy similarity measure: a qualitative point of view. In: *Lecture Notes in Computer Sci., vol. 6178: Computational Intelligence for Knowledge-Based Systems Design. IPMU 2010. E. Hüllermeier, R. Kruse, F. Hoffmann (eds.)*, Berlin, Heidelberg: Springer, 2010. P. 1–10. DOI: [10.1007/978-3-642-14049-5_1](https://doi.org/10.1007/978-3-642-14049-5_1)
7. Camastra F. et al., Fuzzy similarity-based hierarchical clustering for atmospheric pollutants prediction. In: *Lecture Notes in Computer Sci., vol. 11291: Fuzzy Logic and Applications. WILF 2018. Fullér R., Giove S., Masulli F. (eds.)*. Cham: Springer, 2019. P. 123–133. DOI: [10.1007/978-3-030-12544-8_10](https://doi.org/10.1007/978-3-030-12544-8_10)
8. Cheng S.-H., Chen S.-M., Jian W.-S. Fuzzy time series forecasting based on fuzzy logical relationships and similarity measures. *Inform. Sci.*, 2016. Vol. 327. P. 272–287. DOI: [10.1016/j.ins.2015.08.024](https://doi.org/10.1016/j.ins.2015.08.024)
9. Chen S.-M., Yeh M.-S., Hsiao P.-Y. A comparison of similarity measures of fuzzy values. *Fuzzy Sets and Systems*, 1995. Vol. 72, No. 1. P. 79–89. DOI: [10.1016/0165-0114\(94\)00284-E](https://doi.org/10.1016/0165-0114(94)00284-E)
10. Ciaramella A., Nardone D., Staiano A. Data integration by fuzzy similarity-based hierarchical clustering. *BMC Bioinformatics*, 2020. Vol. 21, No. Suppl. 10. Art. no. 350. DOI: [10.1186/s12859-020-03567-6](https://doi.org/10.1186/s12859-020-03567-6)
11. Couso I., Garrido L., Sánchez L. Similarity and dissimilarity measures between fuzzy sets: a formal relational study. *Inform. Sci.*, 2013. Vol. 229. P. 122–141. DOI: [10.1016/j.ins.2012.11.012](https://doi.org/10.1016/j.ins.2012.11.012)
12. De Baets B., De Meyer H. Transitivity-preserving fuzzification schemes for cardinality-based similarity measures. *European J. Oper. Res.*, 2005. Vol. 160, No. 3. P. 726–740. DOI: [10.1016/j.ejor.2003.06.036](https://doi.org/10.1016/j.ejor.2003.06.036)
13. Goyal S., Kumar S., Shukla A. K. Fuzzy similarity measure based spectral clustering framework for noisy image segmentation. *Internat. J. Uncertain. Fuzziness Knowledge-Based Systems*, 2017. Vol. 25, No. 4. P. 649–673. DOI: [10.1142/S0218488517500283](https://doi.org/10.1142/S0218488517500283)
14. Guo W., Bi L., Hu B., Dai S. Cosine similarity measure of complex fuzzy sets and robustness of complex fuzzy connectives. *Math. Probl. Eng.*, 2020. Vol. 2020. Art. no. 6716819. DOI: [10.1155/2020/6716819](https://doi.org/10.1155/2020/6716819)
15. Hesamian G., Chachi J. On similarity measures for fuzzy sets with applications to pattern recognition, decision making, clustering, and approximate reasoning. *J. Uncertain Systems*, 2017. Vol. 11, No. 1. P. 35–48.
16. Hu B., Bi L., Dai S. The orthogonality between complex fuzzy sets and its application to signal detection. *Symmetry*, 2017. Vol. 9, No. 9. Art. no. 175. DOI: [10.3390/sym9090175](https://doi.org/10.3390/sym9090175)
17. Hyung L.-K., Song Y.-S., Lee K.-M. Similarity measures between fuzzy sets and between elements. *Fuzzy Sets and Systems*, 1994. Vol. 62, No. 3. P. 291–293. DOI: [10.1016/0165-0114\(94\)90113-9](https://doi.org/10.1016/0165-0114(94)90113-9)
18. Lee S.-H., Pedrycz W., Sohn G. Design of similarity and dissimilarity measures for fuzzy sets on the basis of distance measure. *Int. J. Fuzzy Syst.*, 2009. Vol. 11, No. 2. P. 67–72.

19. Li C., Wu T., Chan F.-T. Self-learning complex neuro-fuzzy system with complex fuzzy sets and its application to adaptive image noise canceling. *Neurocomputing*, 2012. Vol. 94. P. 121–139. DOI: [10.1016/j.neucom.2012.04.011](https://doi.org/10.1016/j.neucom.2012.04.011)
20. Liu P., Ali Z., Mahmood T. The distance measures and cross-entropy based on complex fuzzy sets and their application in decision making. *J. Intell. Fuzzy Syst.*, 2020. Vol. 39, No. 3. P. 3351–3374. DOI: [10.3233/JIFS-191718](https://doi.org/10.3233/JIFS-191718)
21. Ma J., Zhang G., Lu J. A method for multiple periodic factor prediction problems using complex fuzzy sets. *IEEE Trans. Fuzzy Syst.*, 2011. Vol. 20, No. 1. P. 32–45. DOI: [10.1109/TFUZZ.2011.2164084](https://doi.org/10.1109/TFUZZ.2011.2164084)
22. Ma J., Feng L., Yang J. Using complex fuzzy sets for strategic cost evaluation in supply chain downstream. In: *2017 IEEE Int. Conf. on Fuzzy Systems (FUZZ-IEEE)*, 2017. P. 1–6. DOI: [10.1109/FUZZ-IEEE.2017.8015452](https://doi.org/10.1109/FUZZ-IEEE.2017.8015452)
23. Pal A. et al. Similarity in fuzzy systems. *J. Uncertain. Anal. Appl.*, 2014. Vol. 2, No. 18. DOI: [10.1186/s40467-014-0018-0](https://doi.org/10.1186/s40467-014-0018-0)
24. Pappis C.P., Karacapilidis N.I. A comparative assessment of measures of similarity of fuzzy values. *Fuzzy Sets and Systems*, 1993. Vol. 56. P. 171–174. DOI: [10.1016/0165-0114\(93\)90141-4](https://doi.org/10.1016/0165-0114(93)90141-4)
25. Ramot D. et al., Complex fuzzy sets. *IEEE Trans. Fuzzy Syst.*, 2002. Vol. 10, No. 9. P. 171–186. DOI: [10.1109/91.995119](https://doi.org/10.1109/91.995119)
26. Raha S., Hossain A., Ghosh S. Similarity based approximate reasoning: fuzzy control. *J. Appl. Log.*, 2008. Vol. 6. P. 47–71. DOI: [10.1016/j.jal.2007.01.001](https://doi.org/10.1016/j.jal.2007.01.001)
27. Ren S., Ye J. Multicriteria decision-making method using cosine similarity measures for reduct fuzzy sets of interval-valued fuzzy sets. *J. Comput.*, 2014. Vol. 9, no. 1. P. 107–111. DOI: [10.4304/jcp.9.1.107-111](https://doi.org/10.4304/jcp.9.1.107-111)
28. Sahoo L. Similarity measures for Fermatean fuzzy sets and its applications in group decision-making. *Decis. Sci. Letters*, 2022. Vol. 11. P. 167–180. DOI: [10.5267/j.dsl.2021.11.003](https://doi.org/10.5267/j.dsl.2021.11.003)
29. Van der Weken D. et al. A survey on the use and the construction of fuzzy similarity measures in image processing. In: *CIMSA. 2005 IEEE International Conference on Computational Intelligence for Measurement Systems and Applications, Giardini Naxos (ed), Italy, 20-22 July 2005*, 2005. P. 187–192. DOI: [10.1109/CIMSA.2005.1522858](https://doi.org/10.1109/CIMSA.2005.1522858)
30. Wang W. J. New similarity measures on fuzzy sets and on elements. *Fuzzy Sets and Systems*, 1997. Vol. 85, No. 3. P. 305–309. DOI: [10.1016/0165-0114\(95\)00365-7](https://doi.org/10.1016/0165-0114(95)00365-7)
31. Xuecheng L. Entropy, distance measure and similarity measure of fuzzy sets and their relations. *Fuzzy Sets and Systems*, 1992. Vol. 52. P. 305–318. DOI: [10.1016/0165-0114\(92\)90239-Z](https://doi.org/10.1016/0165-0114(92)90239-Z)
32. Yang M.-S., Hung W.-L., Chang-Chien S.-J. On a similarity measure between LR-type fuzzy numbers and its application to database acquisition. *Int. J. Intell. Syst.*, 2005. Vol. 20. P. 1001–1016. DOI: [10.1002/int.20102](https://doi.org/10.1002/int.20102)
33. Yeung D.S., Tsang E. C. C. A comparative study on similarity based fuzzy reasoning methods. *IEEE Trans. SMC Part B: Cyber.*, 1997. Vol. 27, No. 2. P. 216–227. DOI: [10.1109/3477.558802](https://doi.org/10.1109/3477.558802)
34. Zadeh L. A. Fuzzy sets. *Inform. Control*, 1965. Vol. 8, No. 3. P. 338–353. DOI: [10.1016/S0019-9958\(65\)90241-X](https://doi.org/10.1016/S0019-9958(65)90241-X)
35. Zhang G. et al. Operation properties and δ -equalities of complex fuzzy sets. *Int. J. Approx. Reason.*, 2009. Vol. 50, No. 8. P. 1227–1249. DOI: [10.1016/j.ijar.2009.05.010](https://doi.org/10.1016/j.ijar.2009.05.010)
36. Zwick R., Carlstein E., Budescu D. Measures of similarity among fuzzy sets: A comparative analysis. *Int. J. Approximate Reasoning*, 1987. Vol. 1. P. 221–242. DOI: [10.1016/0888-613X\(87\)90015-6](https://doi.org/10.1016/0888-613X(87)90015-6)

AROUND THE ERDÖS–GALLAI CRITERION

Vitaly A. Baransky[†], Tatiana A. Senchonok^{††}

Ural Federal University,
51 Lenina av., Ekaterinburg, 620075, Russian Federation

[†]Vitaly.Baransky@urfu.ru ^{††}Tatiana.Senchonok@urfu.ru

Abstract: By an (integer) partition we mean a non-increasing sequence $\lambda = (\lambda_1, \lambda_2, \dots)$ of non-negative integers that contains a finite number of non-zero components. A partition λ is said to be graphic if there exists a graph G such that $\lambda = \text{dpt } G$, where we denote by $\text{dpt } G$ the degree partition of G composed of the degrees of its vertices, taken in non-increasing order and added with zeros. In this paper, we propose to consider another criterion for a partition to be graphic, the ht-criterion, which, in essence, is a convenient and natural reformulation of the well-known Erdős–Gallai criterion for a sequence to be graphical. The ht-criterion fits well into the general study of lattices of integer partitions and is convenient for applications. The paper shows the equivalence of the Gale–Ryser criterion on the realizability of a pair of partitions by bipartite graphs, the ht-criterion and the Erdős–Gallai criterion. New proofs of the Gale–Ryser criterion and the Erdős–Gallai criterion are given. It is also proved that for any graphical partition there exists a realization that is obtained from some splittable graph in a natural way. A number of information of an overview nature is also given on the results previously obtained by the authors which are close in subject matter to those considered in this paper.

Keywords: Integer partition, Threshold graph, Bipartite graph, Bipartite-threshold graph, Ferrers diagram.

1. Introduction

Everywhere by a graph we mean a simple graph, i.e. a graph without any loops and multiple edges.

An *integer partition*, or simply *partition*, is a non-increasing sequence $\lambda = (\lambda_1, \lambda_2, \dots)$ of non-negative integers that contains a finite number of non-zero components (see [1]). Let $\text{sum } \lambda$ denote the sum of all components of the partition λ and call it the *weight* of the partition λ . It is often said that a partition of λ is a partition of a non-negative integer $n = \text{sum } \lambda$. The *length* $\ell(\lambda)$ of a partition λ is the number of its non-zero components. For convenience, the partition λ will often be written as $\lambda = (\lambda_1, \dots, \lambda_t)$, where $t \geq \ell(\lambda)$, i.e. we will omit the zeros by starting from some zero component without forgetting that the sequence is infinite.

The theory of partitions is one of the actively developing areas of contemporary combinatorics, the foundations of which were laid by L. Euler as early as the 18th century. For some information about the achievements of this theory in the 19th and 20th centuries, see [1].

A partition λ is said to be *graphic* if there is a graph G such that $\lambda = \text{dpt } G$, where we denote by $\text{dpt } G$ the *degree partition* composed by the degrees of vertices taken in non-increasing order with added zeros. In this case, the graph G is called a *realization* of the partition λ , and λ is said to be realized by the graph G . It is clear that adding or removing isolated vertices does not change the degree partition of the graph.

A finite sequence $\lambda = (\lambda_1, \lambda_2, \dots, \lambda_n)$ of non-negative integers such that $\lambda_1 \geq \lambda_2 \geq \dots \geq \lambda_n$ and n is a natural number will be called an *n-sequence*. Such an *n-sequence* is called *graphic* if there is a simple graph G on n vertices such that $\deg(v_1) = \lambda_1, \dots, \deg(v_n) = \lambda_n$, where v_1, \dots, v_n is the sequence of all its vertices; and the graph G is called a *realization* of the *n-sequence* λ , and λ is said to be *realized* by the graph G .

Obviously, an n -sequence $\lambda = (\lambda_1, \lambda_2, \dots, \lambda_n)$ is graphic if and only if the partition $(\lambda_1, \lambda_2, \dots, \lambda_n, 0, 0, \dots)$ obtained from λ by adding zeros, is graphic.

It should be noted that in [4] an algorithm was constructed for generating all graphic n -sequences which does not generate any non-graphic sequences during calculations.

We call an n -sequence $\lambda = (\lambda_1, \lambda_2, \dots, \lambda_n)$ *proper* (*proper n -sequence*) if

- 1) $n - 1 \geq \lambda_1 \geq \lambda_2 \geq \dots \geq \lambda_n$;
- 2) the sum λ of all components of the sequence λ is even.

Obviously, any graphic n -sequence is proper.

The first criterion for an n -sequence to be graphic was found by Erdős and Gallai [14].

Theorem 1 [14, Erdős and Gallai]. *Let $\lambda = (\lambda_1, \lambda_2, \dots, \lambda_n)$ be a proper n -sequence. Then λ is a graphic n -sequence if and only if it is satisfied the inequality*

$$\sum_{i=1}^k \lambda_i \leq k(k-1) + \sum_{i=k+1}^n \min\{k, \lambda_i\}$$

for any $k = 1, \dots, n$.

It is an easy matter to prove that the condition “ $k = 1, \dots, n$ ” can be replaced by the condition “ $k = 1, \dots, r(\lambda)$ ”, where $r(\lambda) = \max\{i | \lambda_i \geq i\}$ is the rank of the n -sequence λ .

The paper [17] considers all seven graphic criteria known by that time: Erdős–Gallai, Ryser, Berge, Fulkerson–Hoffman–McAndrew, Bollobas, Grünbaum, Hässelbarth. It is shown, how they deduced from each other, and a new, more elegant proof of the Erdős–Gallai criterion is given.

In this paper, we propose for consideration (in our terminology) another graphic criterion, the ht-criterion (see Theorem 2), which has the simplest and most natural form. Moreover, as will be seen below, this criterion fits well into the general study of partition lattices.

It should be noted that considerations close to the ht-criterion can be found in [15].

As can be seen below, the ht-criterion can be in essence considered as a reformulation of the Erdős–Gallai criterion which is convenient for applications.

In §2, by fairly simple reasoning, we establish the equivalence of Theorem 2 on the ht-criterion and the Erdős–Gallai Theorem 1.

§3 will provide a transparent proof of the Gale–Ryser theorem on the realization of two partitions by a bipartite graph, that does not use the partition graphicity criteria.

In §4, with the Gale–Ryser theorem and without any partition graphicity criteria, we prove Theorem 2 on the ht-criterion and, therefore, obtain a new natural proof of the Erdős–Gallai theorem. From the proof of Theorem 2 we also extract Theorem 4 and Theorem 5 on the existence of a special kind of realizations for arbitrary partitions, and this result is one of the main ones in this paper.

§5 will give another proof of the Gale–Ryser theorem, in which the ht-criterion is used. As a result, we will show how the Gale–Ryser theorem, the ht-criterion Theorem 2 and the Erdős–Gallai Theorem 1 can be derived from each other.

At the end of paragraphs 4 and 5, we give a brief review of the previously obtained results of authors which are close in subject matter to those considered in this paper.

2. On the ht-criterion

Let us first give the necessary definitions.

We denote by IPL the set of all partitions of all natural numbers with added zero partition, and by $IPL(m)$ for a non-negative integer m we denote the set of all its partitions. On the sets IPL and $IPL(m)$, consider the dominance relation \leq [13], by setting $\lambda \leq \mu$ if

$$\lambda_1 + \lambda_2 + \dots + \lambda_i \leq \mu_1 + \mu_2 + \dots + \mu_i$$

for any $i = 1, 2, \dots$, i.e. the prefix partial sums of the partition λ do not exceed the corresponding prefix partial sums of the partition μ .

The partition can be conveniently depicted as a *Ferrers diagram*, which can be thought of as a set of square boxes of the same size (see an example in Fig. 1, which shows the partition $(6, 5, 4, 4, 3, 2, 1, 1)$ of the number 26, the length of this partition is 8). We will use Cartesian notation for Ferrers diagrams aligned to the bottom-left corner of the 1st quadrant. Components correspond to columns and decrease in size from left to right. The coordinates for boxes resemble the standard Cartesian coordinates for the Euclidean plane.

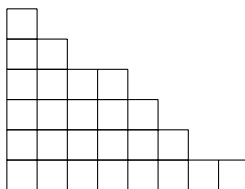

Figure 1. The Ferrers diagram of the partition $(6, 5, 4, 4, 3, 2, 1, 1)$.

Let us define two types of elementary transformations (see [2–5]) of the partition $\lambda = (\lambda_1, \lambda_2, \dots, \lambda_n)$, where $n = \ell(\lambda) + 1$.

Let there be natural numbers $i, j \in \{1, \dots, n\}$ such that $i < j \leq \ell(\lambda) + 1$ and

- 1) $\lambda_i - 1 \geq \lambda_{i+1}$,
- 2) $\lambda_{j-1} \geq \lambda_j + 1$,
- 3) $\lambda_i = \lambda_j + \delta$, where $\delta \geq 2$.

We will say that the partition $\eta = (\lambda_1, \dots, \lambda_i - 1, \dots, \lambda_j + 1, \dots, \lambda_n)$ is obtained from the partition $\lambda = (\lambda_1, \dots, \lambda_i, \dots, \lambda_j, \dots, \lambda_n)$ by an *elementary transformation of the first type* (or through *box movement*). It should be noted that η differs from λ on exactly two components with numbers i and j .

For the Ferrers diagram, such a transformation means moving the top box from the i -th column to the right to the top of the j -th column. The conditions 1), 2) and 3) guarantee that after such a move, a partition will again be obtained. It should be noted that a box can also be thrown to the zero component with the number $\ell(\lambda) + 1$.

The fact that η is obtained from λ by moving a box will be briefly written in the form $\lambda \rightarrow \eta$. It should be noted that an elementary transformation of the first type preserves the weight of the partition, while the length of the partition can be preserved or lifted by 1.

We now define elementary transformations of the second type for the partition $\lambda = (\lambda_1, \lambda_2, \dots)$.

Let $\lambda_i - 1 \geq \lambda_{i+1}$, where $i \leq \ell(\lambda)$. A transformation that replaces λ by

$$\eta = (\lambda_1, \dots, \lambda_{i-1}, \lambda_i - 1, \lambda_{i+1}, \dots)$$

will be called an *elementary transformation of the second type* (or a *box removal*).

As in the previous case, we will briefly write $\lambda \rightarrow \eta$, i. e., the notation $\lambda \rightarrow \eta$ means that η obtained from λ by an elementary transformation of the first or second type. It should be noted that box removal reduces the weight of the partition by exactly 1, while the length of the partition can be preserved or lowered by 1.

On the set IPL and on sets of the form $IPL(m)$, we define the relation \leq by setting $\eta \leq \lambda$ if η can be obtained from λ by sequentially applying a finite number (possibly a zero one) of elementary transformations of the stated types.

Of course, in the case of $IPL(m)$ we are forced to use only elementary transformations of the first type, which do not change the weight of the partitions. It was proved in [3] and [5] that the relation \leq on each of the considered sets coincides with the dominance relation \trianglelefteq , and each of these sets is a lattice.

It is essential to note that the use of elementary transformations is often more convenient than the use of inequalities appearing in the definition of the dominance relation.

It should be noted that the IPL lattice is a disjoint union of lattices $IPL(m)$, where m ranges over non-negative integers corresponding to some natural transitive system of embeddings [5].

Let $\lambda = (\lambda_1, \lambda_2, \dots)$ be a partition. We determine the *rank* $r(\lambda)$ of the partition λ by setting $r(\lambda) = \max\{i | \lambda_i \geq i\}$. Obviously, the rank $r = r(\lambda)$ of a partition λ is equal to the number of boxes on the main diagonal of the Ferrers diagram of this partition. The maximum square made up of boxes and symmetrical about the main diagonal is called the *Durfey square* of the partition λ (see Fig. 2).

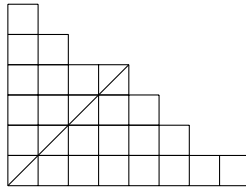

Figure 2. The main diagonal in the Durfey square.

Fig. 2 shows the partition $\lambda = (6, 5, 4, 4, 3, 2, 1, 1)$. Here $r(\lambda) = 4$ and the Durfey square consists of $16 = 4 \cdot 4$ boxes. Any row and any column of a Durfey square consists of $r = r(\lambda)$ boxes.

For each partition λ , we will consider an conjugate partition λ^* whose components are equal to the number of boxes in the corresponding rows of the Ferrers diagram of the partition λ . It is clear that the Ferrers diagram of the partition λ^* can be obtained from the Ferrers diagram of the partition λ by mirror symmetry with respect to the main diagonal. For Fig. 2, $\lambda^* = (8, 6, 5, 4, 2, 1)$ is satisfied. Of course, the equality $r(\lambda^*) = r(\lambda)$ is true.

It should be noted (see [3]) that for any $m \in \mathbb{N}$ the mapping $\lambda \rightarrow \lambda^*$ is an involutive anti-automorphism of the lattice $IPL(m)$ such that $(\lambda^*)^* = \lambda$ and the condition $\gamma_1 \leq \gamma_2$ implies the condition $\gamma_1^* \geq \gamma_2^*$.

Let $\xi, \eta \in IPL(m)$ and f be an elementary transformation of the first type $\xi \rightarrow \eta$, transforming ξ into η . It is plain to see (see Fig. 3) that the inverse transformation f^* to the transformation f is an elementary transformation of the first type $\eta^* \rightarrow \xi^*$, transforming η^* into ξ^* . Ferrers diagrams stated in Fig. 3 can also be considered as Ferrers diagrams of the corresponding conjugate partitions, only then they need to be considered lying “on their side”, i. e., the components should be read in rows.

Similarly, if f is an elementary transformation of the second type $\xi \rightarrow \eta$ (box removal) that transforms ξ into η , then the inverse transformation f^* of f is a *box insertion* that transforms η^*

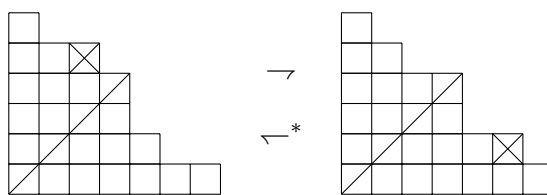

Figure 3. The elementary transformation of the first type and the inverse transformation.

into ξ^* , i. e., $\eta^* \rightarrow \xi^*$ (it is convenient to use the same symbol \rightarrow to indicate box insertion).

We now define the head and tail of the partition $\lambda = (\lambda_1, \lambda_2, \dots)$, the rank of which is equal to r .

As the *head* $\text{hd}(\lambda)$, we take the partition that is obtained from the partition λ by reducing the first r components by the same number $r-1$ and zeroing all components with numbers $r+1, r+2, \dots$ (for an example, see the diagram in Fig. 4).

As the *tail* $\text{tl}(\lambda)$ we take a partition for which the Ferrers diagram of the conjugate partition is obtained from the Ferrers diagram of the partition λ by deleting the first r columns, i. e. the Ferrers diagram of the partition $\text{tl}(\lambda)^*$ is located to the right of the Durfey square (see Fig. 4).

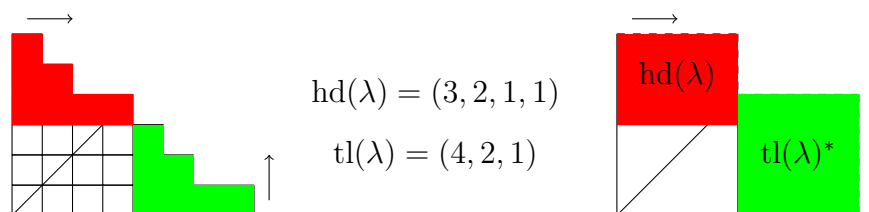

Figure 4. The head and the tail of the partition $(6, 5, 4, 4, 3, 2, 1, 1)$.

The arrows in Fig. 4 indicate the directions in which the components of the partitions $\text{hd}(\lambda)$ and $\text{tl}(\lambda)$ are read. It is clear that the upper row of the Durfey square enters the Ferrers diagram of the partition $\text{hd}(\lambda)$, the partition $\text{hd}(\lambda)$ is “read” by column from left to right, and the length of the partition $\text{hd}(\lambda)$ is equal to r . The partition $\text{tl}(\lambda)$ is “read” by row from bottom to top and the length of the partition $\text{tl}(\lambda)^*$ is equal to $\ell(\lambda) - r(\lambda)$, and the length of the partition $\text{tl}(\lambda)$ is equal to $\text{tl}(\lambda)_1^*$ — the value the first component of the partition $\text{tl}(\lambda)^*$, hence $\ell(\text{tl}(\lambda)) \leq r(\lambda)$.

For n -sequences, the concepts of *rank*, *head*, and *tail* are introduced in exactly the same way.

In order to consider the ht-criterion for partitions to be graphic, we present two auxiliary lemmas.

Lemma 1. *Let $\lambda = (\lambda_1, \lambda_2, \dots, \lambda_n)$ be an n -sequence. Then for any $k = 1, \dots, r = r(\lambda)$, the condition*

$$\sum_{i=1}^k \lambda_i \leq k(k-1) + \sum_{i=k+1}^n \min\{k, \lambda_i\} \tag{2.1}$$

is equivalent to the condition

$$\sum_{i=1}^k \text{hd}(\lambda)_i \leq \sum_{i=1}^k \text{tl}(\lambda)_i,$$

where $\text{hd}(\lambda)_i$ and $\text{tl}(\lambda)_i$ are the i -components, respectively, of the head and tail of the partition λ for any $i = 1, \dots, k$.

P r o o f. Note first that for $k = 1, \dots, r$ the sum

$$\sum_{i=k+1}^n \min\{k, \lambda_i\}$$

is equal to the number of boxes of the Ferrers diagram of the sequence λ located in the strip standing at the intersection of rows with numbers from 1 to k and columns with numbers from $k+1$ to n (see the shaded area in Fig. 5).

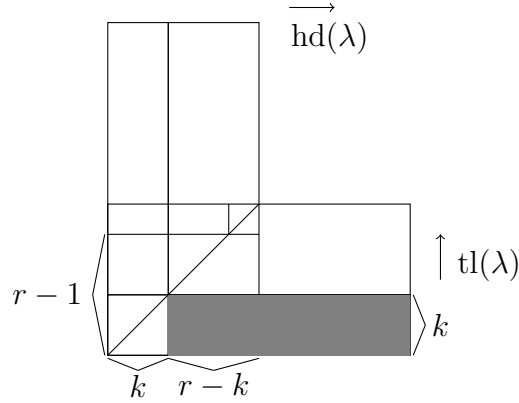

Figure 5. The Ferrers diagram of the sequence.

Let us rewrite inequality (2.1) in the equivalent form

$$\sum_{i=1}^k \lambda_i - k(k-1) - k(r-k) \leq \sum_{i=k+1}^n \min\{k, \lambda_i\} - k(r-k),$$

after transformations, the resulting inequality is equivalent to the inequality

$$\sum_{i=1}^k \lambda_i - k(r-1) \leq \sum_{i=k+1}^n \min\{k, \lambda_i\} - k(r-k).$$

It is plain to see that

$$\sum_{i=1}^k \lambda_i - k(r-1) = \sum_{i=1}^k \text{hd}(\lambda)_i \quad \text{and} \quad \sum_{i=k+1}^n \min\{k, \lambda_i\} - k(r-k) = \sum_{i=1}^k \text{tl}(\lambda)_i.$$

Therefore, inequality (2.1) is equivalent to the inequality

$$\sum_{i=1}^k \text{hd}(\lambda)_i \leq \sum_{i=1}^k \text{tl}(\lambda)_i.$$

□

Lemma 2. Let $\lambda = (\lambda_1, \lambda_2, \dots, \lambda_n)$ be an n -sequence and $\text{hd}(\lambda) \leq \text{tl}(\lambda)$. Then $\lambda_1 \leq n-1$.

P r o o f. Let $r = r(\lambda)$. The condition $\text{hd}(\lambda) \leq \text{tl}(\lambda)$ implies $\text{hd}(\lambda)_1 \leq \text{tl}(\lambda)_1$, so

$$\lambda_1 - (r - 1) \leq \ell(\lambda) - r.$$

Therefore,

$$\lambda_1 \leq \ell(\lambda) - 1 \leq n - 1.$$

□

Since $\ell(\text{hd}(\lambda)) = r(\lambda)$ and $\ell(\text{tl}(\lambda)) \leq r(\lambda)$ for any partition λ , due to Lemmas 1 and 2 the statement of the Erdős–Gallai theorem is equivalent to the following statement.

Theorem 2. *Let $\lambda = (\lambda_1, \lambda_2, \dots)$ be an arbitrary nonzero partition of even weight. Then λ is a graphic partition if and only if*

$$\text{hd}(\lambda) \leq \text{tl}(\lambda).$$

The criterion for a partition to be graphic specified in Theorem 2 will be called the *ht-criterion*.

3. About the Gale–Ryser theorem

Our next main goal is to prove Theorem 2 without using the Erdős–Gallai theorem and other criteria for graphic partitions. To do this, we first give a direct, transparent proof of the well-known Gale–Ryser theorem on the representation of a pair of partitions by a bipartite graph, in which we will not use any of the criteria for the graphicity of partitions.

For a bipartite graph $H = (V_1, E, V_2)$, where V_1 and V_2 are its parts, we denote by $\text{dpt}_H(V_1)$ and $\text{dpt}_H(V_2)$ the degree partitions corresponding to its parts, i. e. partitions composed of the degrees of the vertices of the corresponding parts in non-increasing order and added with zeros.

Theorem 3 [16, Gale D., Ryser H.J. (1957)]. *Let $\alpha = (\alpha_1, \alpha_2, \dots)$ and $\beta = (\beta_1, \beta_2, \dots)$ be nonzero partitions. Then there is a bipartite graph $H = (V_1, E, V_2)$ such that $\text{dpt}_H(V_1) = \alpha$ and $\text{dpt}_H(V_2) = \beta$ if and only if $\text{sum}(\alpha) = \text{sum}(\beta)$ and $\alpha \leq \beta^*$.*

We need the following

Lemma 3. *Let $G = (V, E)$ be a graph, $V = \{v_1, v_2, \dots, v_n\}$ and $\lambda = (\lambda_1, \lambda_2, \dots)$ is a degree partition corresponding to the graph G such that $\lambda_i = \deg(v_i)$ for any $i = 1, \dots, \ell(\lambda)$ and $\lambda_j = 0$ for any $j > \ell(\lambda)$. Then $\text{hd}(\lambda) \leq \text{tl}(\lambda)$.*

P r o o f. By virtue of Lemma 1, it suffices to check the validity of inequality (2.1) for any $k = 1, \dots, r = r(\lambda)$. For $k = 1, \dots, r$, we estimate the sum

$$\sum_{i=1}^k \lambda_i.$$

Let us first estimate the part of this sum contributed by edges from $G(\{v_1, v_2, \dots, v_k\})$. Obviously, $\deg_G(v_i) \leq k - 1$ for any $i = 1, \dots, k$. Therefore, this part of the sum does not exceed $k(k - 1)$.

Let us now estimate the contribution to the sum made by edges of the form $v_j v_i$, where $1 \leq j \leq k$ and $k + 1 \leq i \leq n$. For a given i such that $k + 1 \leq i \leq n$, the number of such edges does not exceed k and does not exceed λ_i , i. e., does not exceed $\min\{k, \lambda_i\}$.

Consequently, inequality (2.1) is satisfied for any $k = 1, \dots, r = r(\lambda)$, and therefore, by virtue of Lemma 1, the inequality $\text{hd}(\lambda) \leq \text{tl}(\lambda)$ also holds. \square

A graph G is said to be *splitable* if the set of its vertices can be represented as a disjoint union of a clique V_1 and a coclique V_2 (i. e., $V_1 \cap V_2 = \emptyset$, V_1 generates a complete subgraph $K(V_1)$, and V_2 generates a zero subgraph $O(V_2)$ with an empty set of edges). For such a graph G , the set of all edges can be represented as a disjoint union of the set of all edges of the complete subgraph $K(V_1)$ and the set E of all its edges connecting vertices from V_1 with vertices from V_2 . Therefore, it is convenient to represent a splitable graph G in the form $G = (K(V_1), E, O(V_2))$. We will simply write $G = (K(V_1), E, V_2)$.

The following lemma proves the necessity of the conditions in the Gale–Ryser theorem.

Lemma 4. *Let $H = (V_1, E, V_2)$ be an arbitrary bipartite graph and $\text{dpt}(V_1) = \alpha$, $\text{dpt}(V_2) = \beta$ be the degree partitions of its parts. Then*

- 1) $\text{sum}(\alpha) = \text{sum}(\beta) = m$, where $m = |E|$;
- 2) $\alpha \leq \beta^*$.

(It should be noted that the condition $\alpha \leq \beta^*$ is equivalent to the condition $\beta \leq \alpha^*$, since the transformation $\gamma \rightarrow \gamma^*$ is an involutive antiautomorphism of the lattice $IPL(m)$.)

P r o o f. 1) It is obvious.

2) Without loss of generality, we will assume that H does not have any isolated vertices. Let $V_1 = \{u_1, u_2, \dots, u_p\}$ and $V_2 = \{v_1, v_2, \dots, v_q\}$, where $\alpha_i = \deg(u_i)$ for any $i = 1, \dots, p$ and $\beta_j = \deg(v_j)$ for any $j = 1, \dots, q$.

Let us embed the graph H into a splitable graph $H^+ = (K(V_1), E, V_2)$ by adding to H all possible edges connecting pairs of different vertices from V_1 . In the graph H^+ , the set V_1 is a clique and the set V_2 is a coclique. Then

$$\alpha_1 + (p - 1) \geq \alpha_2 + (p - 1) \geq \dots \geq \alpha_p + (p - 1) \geq p \geq \beta_1 \geq \beta_2 \geq \dots \geq \beta_q,$$

i. e.

$$\text{dpt}(H^+) = (\alpha_1 + (p - 1), \alpha_2 + (p - 1), \dots, \alpha_p + (p - 1), \beta_1, \beta_2, \dots, \beta_q).$$

Let $\text{dpt}(H^+) = \lambda$. Then

$$r(\lambda) = p, \quad \text{hd}(\lambda) = (\alpha_1, \alpha_2, \dots, \alpha_p) = \alpha, \quad \text{tl}^*(\lambda) = (\beta_1, \beta_2, \dots, \beta_q) = \beta.$$

By virtue of Lemma 3, we have $\text{hd}(\lambda) \leq \text{tl}(\lambda)$. Since $\text{tl}(\lambda) = \beta^*$, we obtain $\alpha \leq \beta^*$. \square

To prove the sufficiency of the Gale–Ryser theorem conditions, we need additional definitions and two lemmas.

Let (x, v, y) be a triple of different vertices of the graph $G = (V, E)$ such that $xv \in E$ and $vy \notin E$. We call such a triple 1) *lifting* if $\deg(x) \leq \deg(y)$, 2) *lowering* if $\deg(x) \geq 2 + \deg(y)$, and 3) *preserving* if $\deg(x) = 1 + \deg(y)$.

A transformation φ of a graph G such that $\varphi(G) = G - xv + vy$, i. e., first the edge xv is removed from G and then the edge vy is added (see Fig. 6), is called the *rotation of the edge* (in the graph G around vertex v) corresponding to the triple (x, v, y) .

The rotation of an edge in the graph $\varphi(G)$ corresponding to the triple (y, v, x) is called the *reverse rotation of an edge* for the rotation φ .

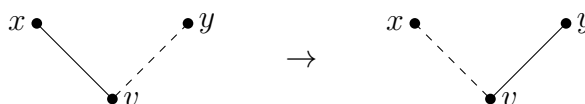

Figure 6. The rotation of an edge.

The rotation of an edge in G corresponding to a triple (x, v, y) is called 1) *lifting* if the triple (x, v, y) is lifting, 2) *lowering* if the triple (x, v, y) is lowering, and 3) *preserving* if the triple (x, v, y) is preserving.

It should be noted that the cases when $\deg(x) = 1$ or $\deg(y) = 0$ will be considered admissible, i. e. after the rotation of an edge, an isolated vertex may appear or the rotation of an edge will occur in the graph G with the addition of a new isolated vertex.

It should be noted that the rotation of an edge in the graph G is lowering if and only if the reverse rotation of the edge is lifting.

If the graph G_2 obtained from the graph G_1 by rotating an edge, then we write $G_1 \rightarrow G_2$.

Let $\text{dpt}(G)$ be the degree partition corresponding to the graph G and φ be the rotation of the edge in the graph G corresponding to the triple (x, v, y) , where $xv \in E$ and $vy \notin E$. Then the following assertions are correct.

1. If φ is a lifting rotation of an edge, then $\text{dpt}(G) < \text{dpt}(\varphi(G))$, moreover, $\text{dpt}(G)$ is obtained from $\text{dpt}(\varphi(G))$ with one elementary transformation of the first type, and G is obtained from $\varphi(G)$ with the reverse (lowering) rotation of an edge.
2. If φ is the lowering rotation of an edge, then $\text{dpt}(G) > \text{dpt}(\varphi(G))$, moreover, $\text{dpt}(\varphi(G))$ is obtained from $\text{dpt}(G)$ with one elementary transformation of the first type, and G is obtained from $\varphi(G)$ with the reverse (lifting) rotation of an edge.
3. If φ is the preserving rotation of an edge, then $\text{dpt}(G) = \text{dpt}(\varphi(G))$, and G is obtained from $\varphi(G)$ with the reverse (preserving) rotation of an edge.

Let (x, v, y) be a triple of distinct vertices of a bipartite graph $H = (V_1, E, V_2)$ such that $xv \in E$ and $vy \notin E$. If $x, y \in V_1$ and $v \in V_2$, then we call the triple V_1 -triple, but if $x, y \in V_2$ and $v \in V_1$, then the triple will be called a V_2 -triple. We will say that V_1 -triples correspond to V_1 -rotations of edges, and V_2 -triples correspond to V_2 -rotations of edges.

Lemma 5. 1. Let $H_1 = (V_1, E_1, V_2)$ and $H_2 = (V_1, E_2, V_2)$ be bipartite graphs, and the graph H_2 is obtained from the graph H_1 by the lowering V_1 -rotation of the edge $H_1 \rightarrow H_2$. Then $\text{dpt}_{H_2}(V_1)$ is obtained from $\text{dpt}_{H_1}(V_1)$ with an elementary transformation of the first type, i. e., $\text{dpt}_{H_1}(V_1) \rightarrow \text{dpt}_{H_2}(V_1)$, and $\text{dpt}_{H_2}(V_2) = \text{dpt}_{H_1}(V_2)$.

2. Let $H_1 = (V_1, E_1, V_2)$ be a bipartite graph and the partition μ be obtained from the partition $\text{dpt}_{H_1}(V_1)$ with an elementary transformation of the first type, i. e., $\text{dpt}_{H_2}(V_1) \rightarrow \mu$. Then there exists a bipartite graph $H_2 = (V_1, E_2, V_2)$ that is obtained from the graph H_1 by means of a lowering V_1 -rotation of an edge $H_1 \rightarrow H_2$ and for which $\mu = \text{dpt}_{H_2}(V_1)$ and $\text{dpt}_{H_2}(V_2) = \text{dpt}_{H_1}(V_2)$.

Proof. Assertion 1 is obvious. Let us prove the assertion 2. Let $\text{dpt}_{H_1}(V_1) = (\lambda_1, \dots, \lambda_i, \dots, \lambda_j, \dots, \lambda_t)$, where $\lambda_i \geq 2 + \lambda_j$, $1 \leq i < j \leq t$ and $\mu = (\lambda_1, \dots, \lambda_i - 1, \dots, \lambda_j + 1, \dots, \lambda_t)$. Let for vertices $x, y \in V_1$, $\deg_{H_1}(x) = \lambda_i$ and $\deg_{H_1}(y) = \lambda_j$. Since $\lambda_i > \lambda_j$, there is a vertex $v \in V_2$ such that $xv \in E_1$ and $vy \notin E_1$. Let φ be a lowering V_1 -rotation of an

edge corresponding to the triple (x, v, y) in the graph H_1 . Then $\mu = \text{dpt}_{H_2}(V_1)$ in the graph $H_2 = \varphi(H_1)$. The equality $\text{dpt}_{H_2}(V_2) = \text{dpt}_{H_1}(V_2)$ is obvious, since the lowering V_1 -rotation of an edge does not change the degrees of vertices in V_2 . \square

The following lemma guarantees the sufficiency of the Gale–Ryser theorem conditions.

Lemma 6. *Let $\alpha = (\alpha_1, \alpha_2, \dots)$ and $\beta = (\beta_1, \beta_2, \dots)$ be nonzero partitions such that $\text{sum}(\alpha) = \text{sum}(\beta)$ and $\alpha \leq \beta^*$. Then there is a bipartite graph $H = (V_1, E, V_2)$ such that $\text{dpt}(V_1) = \alpha$ and $\text{dpt}(V_2) = \beta$.*

P r o o f. Let $\ell(\alpha) = p$ and $\ell(\beta) = q$. Take two sets V_1 and V_2 such that $|V_1| = |V_2| = m$, where $m = \text{sum}(\alpha) = \text{sum}(\beta)$. It is clear that $p, q \leq m$. Let $V_1 = \{u_1, u_2, \dots, u_m\}$ and $V_2 = \{v_1, v_2, \dots, v_m\}$.

First, we construct a bipartite graph $H_0 = (V_1, E_0, V_2)$. To do this, it suffices to specify the neighborhoods of its vertices v_1, v_2, \dots, v_m . Let

$$N_{H_0}(v_1) = \{u_1, u_2, \dots, u_{\beta_1}\}, N_{H_0}(v_2) = \{u_1, u_2, \dots, u_{\beta_2}\}, \dots, N_{H_0}(v_q) = \{u_1, u_2, \dots, u_{\beta_q}\}$$

and $N_{H_0}(v_i) = \emptyset$ if $i > q$ (for such i , $\beta_i = 0$). Neighborhoods of vertices v_1, v_2, \dots, v_m form a system of nested subsets in V_1 and uniquely define the graph H_0 .

Let us consider an $m \times m$ bipartite adjacency matrix A of the bipartite graph H_0 , where the columns of the matrix A correspond to the vertices v_1, v_2, \dots, v_m and are numbered from left to right, and the rows correspond to the vertices u_1, u_2, \dots, u_m and are numbered from bottom to top. In matrix A , boxes containing 1's are concentrated in the lower left corner and form a Ferrers diagram for $\beta = (\beta_1, \beta_2, \dots)$, and by reading 1's row by row, we get a Ferrers diagram for β^* , i. e. $\text{dpt}_{H_0}(V_1) = \beta^*$ and $\text{dpt}_{H_0}(V_2) = \beta$.

Example 1. Let $\beta = (3, 2, 1, 1, 0, \dots)$. Then $\beta^* = (4, 2, 1, 0, \dots)$ and $m = 7$. Then the matrix A has the following form:

u_7	0	0	0	0	0	0	0
u_6	0	0	0	0	0	0	0
u_5	0	0	0	0	0	0	0
u_4	0	0	0	0	0	0	0
u_3	1	0	0	0	0	0	0
u_2	1	1	0	0	0	0	0
u_1	1	1	1	1	0	0	0
	v_1	v_2	v_3	v_4	v_5	v_6	v_7

Since $\beta^* \geq \alpha$ and the partitions β^* and α have the same weight m , in $IPL(m)$ there is a sequence of elementary transformations of the first type such that

$$\beta^* = \xi(0) \rightarrow \xi(1) \rightarrow \dots \rightarrow \xi(t) = \alpha.$$

According to this sequence, by applying t times the assertion 2 of Lemma 5, we obtain, with lowering V_1 -rotations of edges, a sequence of bipartite graphs:

$$H_0 = (V_1, E_0, V_2) \rightarrow H_1 = (V_1, E_1, V_2) \rightarrow \dots \rightarrow H_t = (V_1, E_t, V_2)$$

such that $\text{dpt}_{H_i}(V_1) = \xi_{(i)}$ and $\text{dpt}_{H_i}(V_2) = \beta$ for any $i = 0, 1, \dots, t$. The graph $H_t = (V_1, E_t, V_2)$ is the sought one, since $\text{dpt}_{H_t}(V_1) = \xi_{(t)} = \alpha$ and $\text{dpt}_{H_t}(V_2) = \beta$. \square

Gale–Ryser theorem proceeds from Lemmas 4 and 6.

4. Proof of Theorem 2 using the Gale–Ryser theorem

Now our goal is to prove Theorem 2 without using the Erdős–Gallai theorem and other criteria for partitions to be graphic. In addition, along the way, we will prove one of the main results of the paper, Theorem 5, on the existence for any nonzero partition λ of a realization that is obtained from some splittable graph with a certain sequence of lowering rotations of edges.

For this we need two auxiliary lemmas.

- Lemma 7.** 1. Let $H_1 = (V_1, E_1)$ and $H_2 = (V_2, E_2)$ be graphs and let the graph H_2 be obtained from the graph H_1 with the lowering rotation of an edge $H_1 \rightarrow H_2$. Then $\text{dpt}(H_2)$ is obtained from $\text{dpt}(H_1)$ with an elementary transformation of the first type $\text{dpt}(H_1) \rightarrow \text{dpt}(H_2)$.
2. Let $H_1 = (V_1, E_1)$ be a graph and let the partition μ be obtained from the partition $\text{dpt}(H_1)$ with an elementary transformation of the first type $\text{dpt}(H_1) \rightarrow \mu$. Then there exists a graph $H_2 = (V_2, E_2)$ which is obtained from the graph H_1 by means of a lowering rotation of the edge $H_1 \rightarrow H_2$ and for which $\mu = \text{dpt}(H_2)$ is satisfied.

P r o o f. Assertion 1 is obvious. Assertion 2 is proved similarly to assertion 2 of Lemma 5. \square

Lemma 8. For any partition λ of even weight, the number $C = \text{sum tl}(\lambda) - \text{sum hd}(\lambda)$ is even.

P r o o f. Since

$$\text{sum } \lambda = \text{sum hd}(\lambda) + r(r - 1) + \text{sum tl}(\lambda),$$

where $r = r(\lambda)$, $\text{sum tl}(\lambda) + \text{sum hd}(\lambda)$ is even. It follows that the number $\text{sum tl}(\lambda) - \text{sum hd}(\lambda)$ is also even. \square

The necessity of the condition of Theorem 2 is proved in Lemma 3.

Let us now give a proof of the sufficiency of the condition of Theorem 2, in which the Erdős–Gallai criterion and other criteria for the graphicity of partitions are not used, but the Gale–Ryser theorem is used.

Let $\lambda = (\lambda_1, \lambda_2, \dots)$ be an arbitrary nonzero partition of even weight, $\text{hd}(\lambda) \leq \text{tl}(\lambda)$. Our goal is to prove the existence of a realization for the partition λ and to reveal a special kind of the realization that we obtain.

Let $r = r(\lambda)$ be the rank of the partition λ . It should be noted that $\ell(\text{hd}(\lambda)) = r$ and $\ell(\text{tl}(\lambda)) = (\text{tl}^*(\lambda))_1 \leq r$, where $(\text{tl}^*(\lambda))_1$ is the first component of the partition $\text{tl}^*(\lambda)$.

Since $\text{hd}(\lambda) \leq \text{tl}(\lambda)$, there is a sequence of elementary transformations from $\text{tl}(\lambda)$ to $\text{hd}(\lambda)$, and both types of elementary transformations are admissible. Let us apply the algorithm [8] for constructing the shortest sequence of this type. For this, we take the component wise difference of the partitions

$$\text{tl}(\lambda) - \text{hd}(\lambda) = (\text{tl}(\lambda)_1 - \text{hd}(\lambda)_1, \text{tl}(\lambda)_2 - \text{hd}(\lambda)_2, \dots, \text{tl}(\lambda)_r - \text{hd}(\lambda)_r, 0, \dots).$$

Example 2. Assuming that $\lambda = (8, 7, 7, 7, 6, 6, 5, 3, 3, 2, 2)$. Then

$$\begin{aligned} r(\lambda) &= 6, & \text{hd}(\lambda) &= (3, 2, 2, 2, 1, 1), & \text{tl}^*(\lambda) &= (5, 3, 3, 2, 2), \\ C = \text{sum tl}^*(\lambda) - \text{sum hd}(\lambda) &= 15 - 11 = 4, & \text{tl}(\lambda) &= (5, 5, 3, 1, 1). \end{aligned}$$

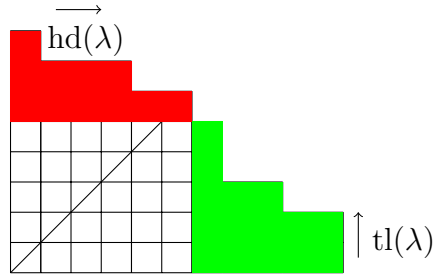

Figure 7. The head and the tail of the partition.

It should be noted that the conditions of Theorem 2 are satisfied since $\text{sum } \lambda = 56$ and

$$\text{hd}(\lambda) = (3, 2, 2, 2, 1, 1) \leq (5, 5, 3, 1, 1) = \text{tl}(\lambda),$$

since the prefix sums of the sequence $(3, 2, 2, 2, 1, 1)$ do not exceed the corresponding prefix sums of the sequence $(5, 5, 3, 1, 1, 0)$. Take the component-wise difference of the partitions $\text{tl}(\lambda)$ and $\text{hd}(\lambda)$:

$$\begin{array}{r} \text{tl}(\lambda) = (5, \quad 5, \quad 3, \quad 1, \quad 1, \quad 0) \\ \text{hd}(\lambda) = (3, \quad 2, \quad 2, \quad 2, \quad 1, \quad 1) \\ \hline \text{tl}(\lambda) - \text{hd}(\lambda) = (+2 \quad +3 \quad +1 \quad -1 \quad 0 \quad -1) \end{array}$$

The partition $\text{tl}(\lambda)$ over the partition $\text{hd}(\lambda)$ in components with numbers 1, 2, and 3 has hills (see [8]) of heights 2, 3, and 1, respectively, and in components with numbers 4 and 6, it has pits (see [8]), each of which has depth 1. It should be noted that the sum of the heights of all hills is C plus the sum of the depths of all pits [8]. A pit is called admissible if adding 1 to it does not change the non-increasing order for the resulting partition (preserves the stepped form of the Ferrers diagram). Here the 6-pit (in the component with number 6), like the 4-pit, is admissible for the partition $\text{tl}(\lambda)$. According to [8], if there is a pit, then there should be an admissible pit.

The algorithm for constructing some shortest sequence of elementary transformations from $\text{tl}(\lambda)$ to $\text{hd}(\lambda)$ [8] consists in sequentially moving a box into an admissible pit from the hill closest to it on the left or in removal the upper box from the last hill; be removal exactly C boxes. The admissible pits in the partition to be transformed will be chosen from right to left. The length of such a sequence is equal to the sum of the heights of all the hills of the partition $\text{tl}(\lambda)$ over the partition $\text{hd}(\lambda)$. Let us build such a sequence in our example. First we remove two boxes, then we fill two pits, and finally we remove two more boxes.

$$\begin{array}{l} \text{tl}(\lambda) = (5, \quad 5, \quad \underline{3}, \quad 1, \quad 1, \quad 0)^4; \quad (5, \quad \underline{5}, \quad 2, \quad 1, \quad 1, \quad 0)^3; \\ \quad \quad \quad +2, \quad +3, \quad +1, \quad -1, \quad 0, \quad -1 \quad \quad +2, \quad +3, \quad 0, \quad -1, \quad 0, \quad -1 \\ \\ (5, \quad \underline{4}, \quad 2, \quad 1, \quad 1, \quad \underline{0})^2; \quad (5, \quad \underline{3}, \quad 2, \quad \underline{1}, \quad 1, \quad 1)^2; \quad (\underline{5}, \quad 2, \quad 2, \quad 2, \quad 1, \quad 1)^2; \\ +2, \quad +2, \quad 0, \quad -1, \quad 0, \quad -1 \quad \quad +2, \quad +1, \quad 0, \quad -1, \quad 0, \quad 0 \quad \quad +2, \quad 0, \quad 0, \quad 0, \quad 0, \quad 0 \\ \\ (\underline{4}, \quad 2, \quad 2, \quad 2, \quad 1, \quad 1)^1; \quad (3, \quad 2, \quad 2, \quad 2, \quad 1, \quad 1)^0 = \text{hd}(\lambda) \\ +1, \quad 0, \quad 0, \quad 0, \quad 0, \quad 0 \quad \quad 0, \quad 0, \quad 0, \quad 0, \quad 0, \quad 0 \end{array}$$

In this context, underlining at each step shows the choice of a hill for the subsequent elementary transformation of the second type or the choice of a hill and an admissible pit for the subsequent elementary transformation of the first type. In addition, at the top right of the current partition, we state the number of boxes that still need to be removed.

Since the partition λ has an even weight, by virtue of Lemma 8 the number C is even. Assuming that $s = 0.5C$. With the component-by-component difference of the partitions $\text{tl}(\lambda)$ and $\text{hd}(\lambda)$, by using the considered algorithm [8], we construct the shortest sequence of elementary transformations from $\text{tl}(\lambda)$ to $\text{hd}(\lambda)$, and at the beginning we remove s boxes and at the end we remove s more boxes:

$$\begin{aligned} \text{tl}(\lambda) &= \eta_{(0)} \rightarrow \eta_{(1)} \rightarrow \cdots \rightarrow \eta_{(s)} = \tau = \tau_{(0)} \rightarrow \cdots \rightarrow \tau_{(t)} = \xi \\ &= \xi_{(0)} \rightarrow \xi_{(1)} \rightarrow \cdots \rightarrow \xi_{(s)} = \text{hd}(\lambda). \end{aligned} \quad (4.2)$$

Since $\ell(\text{tl}(\lambda)) \leq r$ and $\ell(\text{hd}(\lambda)) = r$, in components with numbers greater than r in the difference $\text{tl}(\lambda) - \text{hd}(\lambda)$ all components are equal to 0, i. e. among them there are no hills or pits. Obviously, $\ell(\xi) \leq r$ is true, since in (4.2) when the pits are filled and the hills are removed, the lengths of the partitions cannot become larger than r . Hence, due to the equality $\ell(\text{hd}(\lambda)) = r$ and the fact that in the sequence of transformations

$$\xi = \xi_{(0)} \rightarrow \xi_{(1)} \rightarrow \cdots \rightarrow \xi_{(s)} = \text{hd}(\lambda)$$

only boxes are removed, we get the equality $\ell(\xi) = r$, i. e. for $\xi = (\xi_1, \xi_2, \dots, \xi_r)$ $\xi_r \geq 1$.

Let us also consider a sequence of inverse transformations in reverse order from τ^* to $\text{tl}^*(\lambda)$, which are box insertions:

$$\tau^* = \eta_{(s)}^* \rightarrow \eta_{(s-1)}^* \rightarrow \cdots \rightarrow \eta_{(0)}^* = \text{tl}^*(\lambda).$$

Since in the sequence of transformations from τ^* to $\text{tl}^*(\lambda)$ only block insertions occur and in the partition $\text{tl}^*(\lambda)$ all components do not exceed r , in this sequence all components of all partitions do not exceed r and, in particular, $(\tau^*)_1 \leq r$.

Let us now take a pair of partitions: $\alpha = \xi$ and $\beta = \tau^*$. Then

$$\text{sum } \alpha = \text{sum } \tau = \text{sum } \tau^* = \text{sum } \beta,$$

since the transition from τ to ξ in (4.2) does not remove the boxes, and by virtue of (4.2) $\alpha = \xi \leq \tau = \beta^*$ also holds. Therefore, by virtue of the Gale–Ryser theorem, there is a bipartite graph $H = (V_1, R, V_2)$ such that $\text{dpt}_H(V_1) = \alpha$ and $\text{dpt}_H(V_2) = \beta$. We add V_1 to a complete subgraph by adding $1/2 \cdot r(r-1)$ edges. We obtain a splitable graph $H^+ = (K(V_1), R, V_2)$.

Since $r \geq (\tau^*)_1 = \beta_1$ and the partition $\xi = (\xi_1, \xi_2, \dots, \xi_r)$ satisfies $\xi_r \geq 1$, we have

$$\xi_1 + (r-1) \geq \cdots \geq \xi_r + (r-1) \geq r \geq \beta_1 \geq \beta_2 \geq \cdots$$

Therefore, the degree partition corresponding to the graph H^+ has the form:

$$\text{dpt}(H^+) = (\xi_1 + (r-1), \dots, \xi_r + (r-1), \beta_1, \beta_2, \dots, \beta_{\ell(\beta)}, 0, \dots).$$

Let $\sigma_{(0)} = \text{dpt}(H^+)$. Since $\beta = \tau^*$,

$$\sigma_{(0)} = \text{dpt}(H^+) = (\xi_1 + (r-1), \dots, \xi_r + (r-1), (\tau^*)_1, (\tau^*)_2, \dots, (\tau^*)_{\ell(\tau^*)}, 0, \dots).$$

It is clear that $r(\sigma_{(0)}) = r$, $\text{hd}(\sigma_{(0)}) = \xi = \xi_{(0)}$ and $\text{tl}^*(\sigma_{(0)}) = \tau^* = \eta_{(s)}^*$.

It should be noted that for $s = 0$, due to (4.2) we have

$$\text{hd}(\sigma_{(0)}) = \xi = \text{hd}(\lambda), \quad \text{tl}^*(\sigma_{(0)}) = \tau^* = \text{tl}^*(\lambda)$$

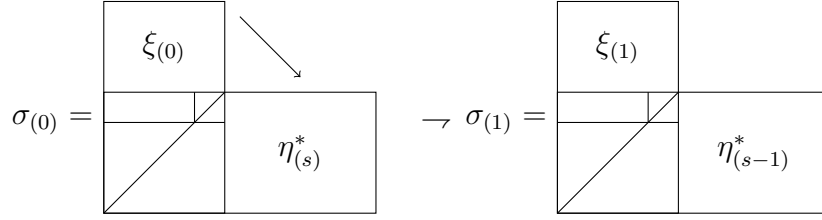

Figure 8. The elementary transformation of the first type obtained by removing and inserting of the box.

and $r(\text{dpt}(H^+)) = r$, so $\text{dpt}(H^+) = \lambda$, i. e. the splitable graph H^+ is a realization of the partition λ .

Thus, in the case $s = 0$, the existence of a splitable realization for λ has been proved.

In what follows, we will assume that $s > 0$.

Starting from the partition $\sigma_{(0)} = \text{dpt}(H^+)$, we sequentially perform s elementary transformations of the first type in the partitions.

At step 1), we remove a box from the head of the partition $\sigma_{(0)}$ by removing the box $\xi_{(0)} \rightarrow \xi_{(1)}$ and insert this box into the partition $\eta_{(s)}^*$ by inserting the box $\eta_{(s)}^* \rightarrow \eta_{(s-1)}^*$.

As a result, we get a partition $\sigma_{(1)}$ such that $r(\sigma_{(1)}) = r$, $\text{hd}(\sigma_{(1)}) = \xi_{(1)}$ and $\text{tl}^*(\sigma_{(1)}) = \eta_{(s-1)}^*$, and $\eta_{(1)}$ is obtained from $\sigma_{(0)}$ with an elementary transformation of the first type $\sigma_{(0)} \rightarrow \sigma_{(1)}$ (see Fig. 8).

At step 2) remove a box from the head of the current partition $\sigma_{(1)}$ by removing the box $\xi_{(1)} \rightarrow \xi_{(2)}$ and insert this box into the partition $\eta_{(s-1)}^*$ by inserting the box $\eta_{(s-1)}^* \rightarrow \eta_{(s-2)}^*$. As a result, we get a partition $\sigma_{(2)}$ such that $r(\sigma_{(2)}) = r$, $\text{hd}(\sigma_{(2)}) = \xi_{(2)}$ and $\text{tl}^*(\sigma_{(2)}) = \eta_{(s-2)}^*$, and $\sigma_{(2)}$ is obtained from $\sigma_{(1)}$ with an elementary transformation of the first type $\sigma_{(1)} \rightarrow \sigma_{(2)}$.

We perform such steps s times.

At step s) we obtain a partition $\sigma_{(s)}$ such that $\text{hd}(\sigma_{(s)}) = \xi_{(s)} = \text{hd}(\lambda)$, $\text{tl}^*(\sigma_{(s)}) = \eta_{(0)}^* = \text{tl}^*(\lambda)$ and $r(\sigma_{(s)}) = r(\lambda)$. Therefore $\sigma_{(s)} = \lambda$ and

$$\text{dpt}(H^+) = \sigma_{(0)} \rightarrow \sigma_{(1)} \rightarrow \sigma_{(2)} \rightarrow \cdots \rightarrow \sigma_{(s)} = \lambda.$$

Now, starting from the graph H^+ , we apply Lemma 7 s times to this sequence, and we obtain graph G such that $\text{dpt}(G) = \lambda$.

Thus, in the case $s > 0$, the sought realization of the partition λ is obtained from the splitable graph H^+ with the s lowering rotations of edges.

The theorem has been proved. \square

It is plain to see that this proof also shows the validity of the two assertions as follows.

Theorem 4. *Let λ be a graphic partition. Then λ has a realization that is a splitable graph if and only if $\text{sum hd}(\lambda) = \text{sum tl}(\lambda)$.*

Theorem 5. *Let λ be a graphic partition and*

$$s = \frac{1}{2}[\text{sum tl}^*(\lambda) - \text{sum hd}(\lambda)].$$

Then the partition λ has a realization G that is obtained from some splitable graph H by s successive lowering rotations and, conversely, H is obtained from G by s successive lifting rotations of edges.

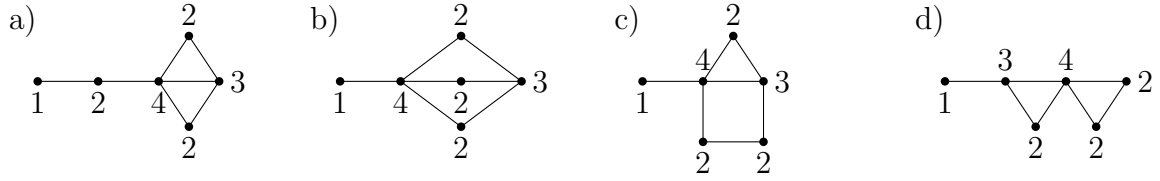

Figure 9. All realizations of the partition.

Example 3. Assuming that $\lambda = (4, 3, 2, 2, 2, 1)$. Here $\text{sum}\lambda = 14$, $r = 2$, $\text{hd}(\lambda) = (3, 2)$ and $\text{tl}(\lambda)^* = (2, 2, 2, 1)$, therefore $\text{tl}(\lambda) = (4, 3)$, $\text{sum}\text{tl}(\lambda) - \text{sum}\text{hd}(\lambda) = 7 - 5 = 2$ and $s = 1$. To get $\text{hd}(\lambda)$ from $\text{tl}(\lambda)$ we need to remove two boxes, hence, $\text{hd}(\lambda) \leq \text{tl}(\lambda)$.

Up to isomorphism and isolated vertices, there are 4 realization of the partition λ (see Fig. 9). According to the proof of Theorem 2, we have

$$\text{tl}(\lambda) = (4, 3) \rightarrow (4, 2) = \tau = \xi \rightarrow (3, 2) = \text{hd}(\lambda).$$

Therefore, $\alpha = \xi = (4, 2)$ and $\beta = \tau^* = (2, 2, 1, 1)$. We sequentially construct a bipartite graph H , a splitable graph H^+ , two vertices of which generate a clique and six vertices generate a coclique, then we perform one lowering rotation of an edge, we obtain the sought realization G of the partition $\lambda = (4, 3, 2, 2, 2, 1)$ (see Fig. 10). Graph G is shown in Fig. 9a.

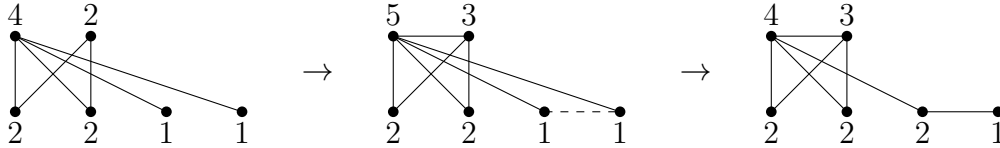

Figure 10. The graph G obtaining.

It is easy to check that in this example, each realization of the partition $\lambda = (4, 3, 2, 2, 2, 1)$ can be obtained from a suitable splitable graph with one lowering rotation of an edge.

At the end of this section, we present a brief review of related results previously obtained by the authors.

It is worth reminding that any graphic partition has an even weight. The set of all graphic partitions of fixed weight $2m$ is an order ideal of the lattice $IPL(2m)$, i. e. it is closed under smaller partitions. A graphic partition λ of weight $2m$ will be called a maximal graphic partition if it is maximal in the set of all graphic partitions of the lattice $IPL(2m)$.

The graph G is called a *threshold* one (see [16]) if its set of vertices can be represented as a disjoint union of the clique V_1 and coclique V_2 (i. e. $V_1 \cup V_2 = \emptyset$, V_1 generates the complete subgraph $K(V_1)$ and V_2 is the zero subgraph $O(V_2)$ in G), and the set of neighbourhoods in G of vertices from V_2 forms a chain of subsets of the set V_1 with respect to the set-theoretic inclusion. It should be noted that the cases $V_1 = \emptyset$ or $V_2 = \emptyset$ are allowed, i. e. the complete and zero graphs are threshold. For the threshold graph G , the set of all edges can be represented as a disjoint union of the set of all edges of the complete subgraph $K(V_1)$ and the set E of all its edges connecting vertices from V_1 with vertices from V_2 . Thus, the threshold graph can be represented as $G = (K(V_1), E, O(V_2))$. We will simply write $G = (K(V_1), E, V_2)$. A bipartite subgraph $H = (V_1, E, V_2)$ will be called its *sandwich subgraph*. In the trivial cases when $V_1 = \emptyset$, or $V_2 = \emptyset$, or V_2 consists of isolated vertices, the sandwich subgraph H is an empty subgraph in G .

The following statements are true, which were proved in [6, 7].

1. An arbitrary partition λ is a maximal graphic partition if and only if $\text{hd}(\lambda) = \text{tl}(\lambda)$.
2. A graph is threshold if and only if it does not contain any lifting triples of vertices.
3. The degree partition corresponding to the graph G is the maximum graphic partition if and only if the graph G is threshold.
4. Any graph can be reduced to a threshold form with a finite sequence of lifting rotations of edges.
5. For an arbitrary graphic partition λ , all of its realizations H , and only they are obtained from the threshold realizations G of maximal graphic partitions μ such that $\mu \geq \lambda$ and $\text{sum}(\mu) = \text{sum}(\lambda)$ with the finite sequences of lowering edge rotations from G to H .

Assume that μ and λ are two arbitrary non-zero partitions and $\mu \geq \lambda$. The *height* (μ, λ) of a partition μ over a partition λ is the number of transformations in the shortest sequence of elementary transformations transforming μ into λ .

For a given graphic partition λ , a maximal graphic partition μ such that $\mu \geq \lambda$ and $\text{sum}(\mu) = \text{sum}(\lambda)$ is said to be closest in height to a partition λ if it has the minimum possible height over λ among all such partitions.

The following assertion was proved in [9].

Assume that λ be an arbitrary graphic partition and μ be the maximum graphic partition closest to it in height. Then

- 1) either $r(\mu) = r(\lambda) - 1$ and $\ell(\text{tl}(\lambda)) < r(\lambda)$, or $r(\mu) = r(\lambda)$;
- 2) $\text{height}(\mu, \lambda) = \text{height}(\text{tl}(\lambda), \text{hd}(\lambda)) - \frac{1}{2}[\text{sum}(\text{tl}(\lambda)) - \text{sum}(\text{hd}(\lambda))] = \frac{1}{2} \sum_{i=1}^r |\text{tl}(\lambda)_i - \text{hd}(\lambda)_i|$, where $r = r(\lambda)$.

An algorithm was found in [9] that constructs some maximum graphic partition μ closest to λ in height such that $r(\mu) = r(\lambda)$. In the case when $\ell(\text{tl}(\mu)) < r(\mu)$, we also found an algorithm that constructs some maximum graphic partition μ closest to λ in height such that $r(\mu) = r(\lambda) - 1$.

Assuming that λ be an arbitrary non-zero graphic partition of weight $2m$ and there is maximal graphic partitions μ such that $\mu \geq \lambda$ and $r(\mu) = r$, where r is some natural number. Then the set of heads of all such maximal graphic partitions μ creates an interval in the lattice $IPL(m - 1/2 \cdot r(r - 1))$. This result was obtained by our PhD-student V.V. Zuev (Ural Federal University). The full version of this result will be published in the article being prepared.

5. Proof of the Gale–Ryser theorem with the ht-criterion

Let us now give another rather simple proof of the Gale–Ryser theorem, in which the ht-criterion is used.

The necessity of the condition of the theorem is satisfied by virtue of Lemma 4.

Let us prove *the sufficiency* of the condition of the theorem. Let $\alpha = (\alpha_1, \alpha_2, \dots)$ and $\beta = (\beta_1, \beta_2, \beta)$ be non-zero partitions such that $\text{sum} \alpha = \text{sum} \beta$ and $\alpha \leq \beta^*$. Assume that $m = \text{sum} \alpha = \text{sum} \beta$, i. e. $\alpha, \beta \in IPL(m)$, $p = \ell(\alpha)$ and $q = \ell(\beta)$.

Since $\alpha_p + (p - 1) \geq p \geq \beta_1$, the sequence as follows

$$\lambda = (\alpha_1 + (p - 1), \dots, \alpha_p + (p - 1), \beta_1, \beta_2, \dots, \beta_q, 0, \dots)$$

is a partition. Obviously, $r(\lambda) = p$ and

$$\text{hd}(\lambda) = (\alpha_1, \alpha_2, \dots) = \alpha, \quad \text{tl}^*(\lambda) = (\beta_1, \beta_2, \dots) = \beta,$$

thus, $\text{tl}(\lambda) = \beta^*$.

It should be noted that

$$\text{sum } \lambda = \text{sum hd}(\lambda) + p(p-1) + \text{sum tl}(\lambda) = \text{sum } \alpha + p(p-1) + \text{sum } \beta = 2m + p(p-1)$$

is even number and $\text{hd}(\lambda) = \alpha \leq \beta^* = \text{tl}(\lambda)$. Therefore, by virtue of the ht-criterion, there is a graph H realizing the partition λ , i. e. a graph H such that $\text{dpt}(H) = \lambda$. It is clear that $\ell(\lambda) = p+q$. Without loss of generality, we assume that H has no isolated vertices and $V_H = \{v_1, v_2, \dots, v_{p+q}\}$.

Assume that $V_1 = \{v_1, v_2, \dots, v_p\}$, where $\deg_H v_i = \alpha_i + (p-1)$ for any $i = 1, 2, \dots, p$, and $V_2 = \{v_{p+1}, v_{p+2}, \dots, v_{p+q}\}$, where $\deg_H v_{p+j} = \beta_j$ for any $j = 1, 2, \dots, q$.

Let us remove all edges in H that connect pairs of different vertices from V_1 . We obtain a graph G . For each $i = 1, 2, \dots, p$, the degree α_i of the vertex v_i will decrease by no more than $p-1$ when passing from H to G , so $\deg_G v_i = \alpha_i + \delta_i$, where δ_i will hold in G , where δ_i is a non-negative integer. Moreover, $\delta_i = 0$ is satisfied if, when passing from H to G , the degree of the vertex v_i decreases by $p-1$.

Case 1. Assume that the set $V_1 = \{v_1, v_2, \dots, v_p\}$ is not a clique in H .

Then there are vertices v_i from the set V_1 such that $\delta_i > 0$. Therefore,

$$\sum_{i=1}^p \deg_G v_i = \sum_{i=1}^p \alpha_i + \sum_{i=1}^p \delta_i > \text{sum } \alpha = m.$$

Therefore, in the graph G there are more than m edges going from V_1 to V_2 . Since $\text{sum } \beta$ is greater than or equal to the number of such edges, we get the $\text{sum } \beta > m$, which contradicts $\text{sum } \beta = m$.

Therefore, this case is impossible.

Case 2. Let the set $V_1 = \{v_1, v_2, \dots, v_p\}$ is a clique in H .

Then $\deg_G v_i = \alpha_i$ for any $i = 1, 2, \dots, p$. Since $\text{sum } \alpha = m$, the number of edges of the graph G going from V_1 to V_2 is equal to m . By virtue of the equality $\text{sum } \beta = m$, it follows that there are no edges in the graph G that connect pairs of different vertices from V_2 . Therefore, V_1 and V_2 are two cocliques in G .

Since $\text{dpt}_G(V_1) = \alpha$ and $\text{dpt}_G(V_2) = \beta$, the graph G is the sought bipartite graph with parts V_1 and V_2 .

The theorem has been proved. □

At the end of this section, we present a brief review of the results previously obtained by the authors and similar in subject matter to the Gale–Ryser theorem.

We first give the necessary definitions.

We say that a bipartite graph $H = (V_1, E, V_2)$ contains a *bipartite 4-pseudocycle* x_1, x_2, x_3, x_4, x_1 , if $x_1, x_3 \in V_2$; $x_2, x_4 \in V_1$; $x_1x_2 \in E$; $x_2x_3 \notin E$; $x_3x_4 \in E$; $x_4x_1 \notin E$.

We call the bipartite graph $H = (V_1, E, V_2)$ a *bipartite-threshold graph* [10] if it does not have any lifting triples of both the first and second parts, i. e. such lifting triples (x, v, y) , that $x, y \in V_1$, $v \in V_2$, or $x, y \in V_2$, $v \in V_1$.

It should be reminded [7] that a graph is a threshold one if and only if it does not contain any lifting triples of vertices. Therefore, bipartite-threshold graphs are analogues of threshold graphs for the class of bipartite graphs.

In [10], the properties of bipartite-threshold graphs were studied. The following assertion is true [10].

Let $H = (V_1, E, V_2)$ be a bipartite graph. Then the following conditions are equivalent

1. H is a sandwich subgraph of the threshold graph $G = (K(V_1), E, V_2)$.
2. H is a sandwich subgraph of the threshold graph $G = (K(V_2), E, V_1)$.
3. The neighborhoods in H of the vertices of each of the parts V_1 and V_2 are nested, i. e. they form chains with respect to the set-theoretical inclusion.
4. Neighborhoods in H of the vertices of the part V_1 are nested, i. e. it forms a chain with respect to the set-theoretical inclusion.
5. Neighborhoods in H of the vertices of V_2 are nested, i. e. it forms a chain with respect to the set-theoretical inclusion.
6. H is a bipartite-threshold graph, i. e. it does not contain lifting V_1 -triples and lifting V_2 -triples.
7. H does not contain lifting V_1 -triples.
8. H does not contain lifting V_2 -triples.
9. $\text{dpt}_H(V_2) = \text{dpt}_H(V_1)^*$.
10. $\text{dpt}_H(V_1) = \text{dpt}_H(V_2)^*$.
11. H has no bipartite 4-pseudocycles.

Assume that α and β be non-zero partitions such that $\text{sum } \alpha = \text{sum } \beta = m$ and $\alpha \leq \beta^*$. A bipartite graph $H = (V_1, E, V_2)$ such that $\text{dpt}_H(V_1) = \alpha$ and $\text{dpt}_H(V_2) = \beta$ will be called a *realization of a pair of partitions* (α, β) . The class of all such bipartite graphs is denoted by $\text{BG}(\alpha, \beta)$ (the *family of bipartite graphs corresponding to the pair* (α, β)).

For an arbitrary partition γ , we denote by $\text{btg}(\gamma, \gamma^*)$ a bipartite threshold graph with parts V_1 and V_2 without any isolated vertices such that $\text{dpt}_G(V_1) = \gamma$ and $\text{dpt}_G(V_2) = \gamma^*$. It should be noted that this graph is unique up to isomorphism (see [12]).

Any bipartite graph $H = (V_1, E, V_2)$ from the family of graphs $\text{BG}(\alpha, \beta)$ can be reduced with finite sequences of bipartite lifting rotations of edges to bipartite threshold graphs, each of which, up to isomorphism and isolated vertices, has the form $\text{btg}(\gamma, \gamma^*)$ for a suitable partition γ , and the graph $H = (V_1, E, V_2)$ is obtained from such graphs $\text{btg}(\gamma, \gamma^*)$ with reverse sequences of bipartite lowering edge rotations.

We denote by $\text{BTG}_\uparrow(\alpha, \beta)$ the family of all bipartite threshold graphs that can be obtained from the graphs of the family $\text{BG}(\alpha, \beta)$ with bipartite lifting rotations (the *family of bipartite threshold graphs over the pair* (α, β)).

Let a bipartite graph $H = (V_1, E_2, V_2)$ be obtained from a bipartite graph $G = (V_1, E_1, V_2)$ with a finite sequence of bipartite lifting edge rotations. The least number of bipartite lifting rotations of edges in the sequence taking G to H is denoted by $\text{updist}(G, H)$ and is called the *upper distance* from G to H .

The following two theorems are valid [12].

1. The family of bipartite threshold graphs $\text{BTG}_\uparrow(\alpha, \beta)$ up to isomorphisms and isolated vertices consists of graphs of the form $\text{btg}(\gamma, \gamma^*)$, where $\alpha \leq \gamma \leq \beta^*$ (compare with the Zuev theorem about the interval of heads of maximal graphic partitions over the given partition given at the end of Section 4).

2. Let the bipartite threshold graph $H = (V_1, E_2, V_2) = \text{btg}(\gamma, \gamma^*) \in \text{BTG}_\uparrow(\alpha, \beta)$ be obtained from the graph $G = (V_1, E_1, V_2) \in \text{BG}(\alpha, \beta)$ with a finite sequence of bipartite lifting rotations of edges. Then

$$\text{updist}(G, H) \geq \text{height}(\beta^*, \alpha) = \text{height}(\alpha^*, \beta).$$

This estimate is achieved on the graphs $\text{btg}(\beta^*, \beta)$ and $\text{btg}(\alpha, \alpha^*)$, i. e. for $\gamma = \beta^*$ and for $\gamma = \alpha$.

It is clear that any bipartite graph is reduced by successive rotations of edges, each of which corresponds to a lifting triple of only the first part, to a bipartite-threshold graph.

Assume that the bipartite graph $H_2 = (V_1, E_2, V_2)$ can be obtained from the graph $H_1 = (V_1, E_1, V_2)$ with a finite sequence of V_1 -rotations of the edges. Let $V_1\text{-dist}(H_1, H_2)$ denote the smallest number of V_1 -rotations of edges in the sequence that maps H_1 to H_2 and call it as the V_1 -distance from H_1 to H_2 . In [11], with the Hungarian algorithm, a polynomial algorithm was constructed that transforms an arbitrary bipartite graph $H = (V_1, E, V_2)$ into a bipartite-threshold graph G with a finite sequence of the smallest possible length consisting of V_1 -rotations of edges, i. e. the length equal to $V_1\text{-dist}(H, G)$.

In conclusion we make the following important remark. Let λ be an arbitrary nonzero partition. It corresponds to two partitions $\alpha = \text{hd}(\lambda)$ and $\beta = \text{tl}(\lambda)^*$. According to the ht-criterion, a partition λ is graphic if and only if its sum is even and $\alpha \leq \beta^*$. It is clear that the ht-criterion is essentially an analog of the Gale–Reiser criterion when passing from the class of bipartite graphs to the class of all graphs. There are many facts indicating a deep analogy between the properties of degree partitions in the class of all bipartite graphs and in the class of all graphs.

REFERENCES

1. Andrews G.E. *The Theory of Partitions*. Cambridge: Cambridge University Press, 1984. 255 p. DOI: [10.1017/CBO9780511608650](https://doi.org/10.1017/CBO9780511608650)
2. Baransky V. A., Koroleva T. A. The lattice of partitions of a positive integer. *Doklady Math.*, 2008. Vol. 77, No. 1. P. 72–75. DOI: [10.1007/s11472-008-1018-z](https://doi.org/10.1007/s11472-008-1018-z)
3. Baransky V. A., Koroleva T. A., Senchonok T. A. On the partition lattice of an integer. *Trudy Inst. Mat. i Mekh. UrO RAN*, 2015. Vol. 21, No. 3. P. 30–36. (in Russian)
4. Baransky V. A., Nadymova T. I., Senchonok T. A. A new algorithm generating graphical sequences. *Sib. Electron. Mat. Izv.*, 2016. Vol. 13. P. 269–279. DOI: [10.17377/semi.2016.13.021](https://doi.org/10.17377/semi.2016.13.021) (in Russian)
5. Baransky V. A., Koroleva T. A., Senchonok T. A. On the partition lattice of all integers. *Sib. Electron. Mat. Izv.*, 2016. Vol. 13. P. 744–753. DOI: [10.17377/semi.2016.13.060](https://doi.org/10.17377/semi.2016.13.060) (in Russian)
6. Baransky V. A., Senchonok T. A. On maximal graphical partitions. *Sib. Electron. Mat. Izv.*, 2017. Vol. 14. P. 112–124. DOI: [10.17377/semi.2017.14.012](https://doi.org/10.17377/semi.2017.14.012) (in Russian)
7. Baransky V. A., Senchonok T. A. On threshold graphs and realizations of graphical partitions. *Trudy Inst. Mat. i Mekh. UrO RAN*, 2017. Vol. 23, No. 2. P. 22–31. (in Russian)
8. Baransky V. A., Senchonok T. A. On the shortest sequences of elementary transformations in the partition lattice. *Sib. Electron. Mat. Izv.*, 2018. Vol. 15. P. 844–852. DOI: [10.17377/semi.2018.15.072](https://doi.org/10.17377/semi.2018.15.072) (in Russian)
9. Baransky V. A., Senchonok T. A. On maximal graphical partitions that are the nearest to a given graphical partition. *Sib. Electron. Mat. Izv.*, 2020. Vol. 17. P. 338–363. DOI: [10.33048/semi.2020.17.022](https://doi.org/10.33048/semi.2020.17.022) (in Russian)
10. Baransky V. A., Senchonok T. A. Bipartite threshold graphs. *Trudy Inst. Mat. i Mekh. UrO RAN*, 2020. Vol. 26, No. 2. P. 56–67. DOI: [10.21538/0134-4889-2020-26-2-56-67](https://doi.org/10.21538/0134-4889-2020-26-2-56-67) (in Russian)
11. Baransky V. A., Senchonok T. A. An algorithm for taking a bipartite graph to the bipartite threshold form. *Trudy Inst. Mat. i Mekh. UrO RAN*, 2022. Vol. 28, No. 4. P. 54–63. DOI: [10.21538/0134-4889-2022-28-4-54-63](https://doi.org/10.21538/0134-4889-2022-28-4-54-63) (in Russian)
12. Baransky V. A., Senchonok T. A. Bipartite-threshold graphs and lifting rotations of edges in bipartite graphs. *Trudy Inst. Mat. i Mekh. UrO RAN*, 2023. Vol. 29, No. 1. P. 24–35. DOI: [10.21538/0134-4889-2023-29-1-24-35](https://doi.org/10.21538/0134-4889-2023-29-1-24-35) (in Russian)

13. Brylawski T. The lattice of integer partitions. *Discrete Math.*, 1973. Vol. 6, No. 3. P. 201–219. DOI: [10.1016/0012-365X\(73\)90094-0](https://doi.org/10.1016/0012-365X(73)90094-0)
14. Erdős P., Gallai T. Graphs with given degree of vertices. *Mat. Lapok*, 1960. Vol. 11. P. 264–274. (in Hungarian)
15. Kohnert A. Dominance order and graphical partitions. *Elec. J. Comb.*, 2004. Vol. 11, No. 1. Art. no. N4. P. 1–17. DOI: [10.37236/1845](https://doi.org/10.37236/1845)
16. Mahadev N. V. R., Peled U. N. *Threshold Graphs and Related Topics*. Ser. Annals of Discr. Math., vol. 56. Amsterdam: North-Holland Publishing Co., 1995. 542 p.
17. Sierksma G., Hoogeveen H. Seven criteria for integer sequences being graphic. *J. Graph Theory*, 1991. Vol. 15, No. 2. P. 223–231. DOI: [10.1002/jgt.3190150209](https://doi.org/10.1002/jgt.3190150209)

STATISTICAL CONVERGENCE IN A BICOMPLEX VALUED METRIC SPACE

Subhajit Bera[†], Binod Chandra Tripathy^{††}

Tripura University,
Suryamaninagar-799022, Agartala, India

[†]berasubhajit0@gmail.com ^{††}tripathybc@gmail.com

Abstract: In this paper, we study some basic properties of bicomplex numbers. We introduce two different types of partial order relations on bicomplex numbers, discuss bicomplex valued metric spaces with respect to two different partial orders, and compare them. We also define a hyperbolic valued metric space, the density of natural numbers, the statistical convergence, and the statistical Cauchy property of a sequence of bicomplex numbers and investigate some properties in a bicomplex metric space and prove that a bicomplex metric space is complete if and only if two complex metric spaces are complete.

Keywords: Partial order, Bicomplex valued metric space, Statistical convergence.

1. Introduction

The concept of statistical convergence for real numbers was introduced by Fast [6], Buck [2], and Schoenberg [12] independently. Later, the concept was studied and linked with summability theory by Salat [11], Fridy [7], Tripathy [17, 19], Rath and Tripathy [8], Tripathy and Sen [18], Tripathy and Nath [16], and many others.

The concept of bicomplex numbers has been investigated from different aspects by Segre [13], Wagh [20], Srivastava and Srivastava [15], Sager and Sager [10], Rochon and Shapiro [9], Beg et al. [3], and Singh [14]. In this paper, we study different types of partial order relations on bicomplex numbers and discuss the concept of statistical convergence in bicomplex valued metric spaces.

Das et al. [5] and many other researchers discussed the statistical convergence in a metric space. In this paper, we investigate statistically convergent and statistically Cauchy sequences in a bicomplex valued metric space.

In what follows, C_0 , C_1 , and C_2 denote the set of real, complex, and bicomplex numbers, respectively.

2. Definitions and preliminaries

2.1. Bicomplex numbers

The concept of bicomplex numbers was introduced by Segre [13]. A bicomplex number is defined as

$$\xi = x_1 + i_1x_2 + i_2x_3 + i_1i_2x_4,$$

where $x_1, x_2, x_3, x_4 \in C_0$ and the independent units i_1 and i_2 are such that $i_1^2 = i_2^2 = -1$ and $i_1i_2 = i_2i_1$. The set of bicomplex numbers C_2 is defined as

$$C_2 = \{\xi : \xi = x_1 + i_1x_2 + i_2x_3 + i_1i_2x_4, \quad x_1, x_2, x_3, x_4 \in C_0\},$$

i.e.,

$$C_2 = \{\xi : \xi = z_1 + i_2 z_2, \quad z_1, z_2 \in C_1\}.$$

There are four idempotent elements in C_2 , they are $0, 1, e_1 = (1 + i_1 i_2)/2$, and $e_2 = (1 - i_1 i_2)/2$, two of which, e_1 and e_2 , are nontrivial such that $e_1 + e_2 = 1$ and $e_1 e_2 = 0$.

Every bicomplex number $\xi = z_1 + i_2 z_2$ can be uniquely expressed as the combination of e_1 and e_2 ; namely,

$$\xi = z_1 + i_2 z_2 = (z_1 - i_1 z_2)e_1 + (z_1 + i_1 z_2)e_2 = \mu_1 e_1 + \mu_2 e_2,$$

where $\mu_1 = (z_1 - i_1 z_2)$ and $\mu_2 = (z_1 + i_1 z_2)$.

A bicomplex number $\xi = x_1 + i_1 x_2 + i_2 x_3 + i_1 i_2 x_4$ is said to be a hyperbolic number if $x_2 = 0$ and $x_3 = 0$. The set of hyperbolic numbers is denoted by \mathcal{H} .

The Euclidean norm $\|\cdot\|$ on C_2 is defined as

$$\|\xi\|_{C_2} = \sqrt{x_1^2 + x_2^2 + x_3^2 + x_4^2} = \sqrt{|z_1|^2 + |z_2|^2} = \sqrt{\frac{|\mu_1|^2 + |\mu_2|^2}{2}},$$

where

$$\xi = x_1 + i_1 x_2 + i_2 x_3 + i_1 i_2 x_4 = z_1 + i_2 z_2 = \mu_1 e_1 + \mu_2 e_2$$

and

$$\mu_1 = z_1 - i_1 z_2, \quad \mu_2 = z_1 + i_1 z_2, \quad e_1 = \frac{1 + i_1 i_2}{2}, \quad e_2 = \frac{1 - i_1 i_2}{2}.$$

With this norm, C_2 is a Banach space, also C_2 is a commutative algebra.

The product of two bicomplex numbers satisfies the inequality

$$\|\xi \cdot \eta\|_{C_2} \leq \sqrt{2} \|\xi\|_{C_2} \cdot \|\eta\|_{C_2}.$$

Definition 1.

- (i) The i_1 -conjugate of a bicomplex number $\xi = z_1 + i_2 z_2$ is denoted by ξ^* and is defined as $\xi^* = \bar{z}_1 + i_2 \bar{z}_2$ for all $z_1, z_2 \in C_1$; here \bar{z}_1 and \bar{z}_2 are the complex conjugates of z_1 and z_2 , respectively, and $i_1^2 = i_2^2 = -1$.
- (ii) The i_2 -conjugate of a bicomplex number $\xi = z_1 + i_2 z_2$ is denoted by $\bar{\xi}$ and is defined as $\bar{\xi} = z_1 - i_2 z_2$ for all $z_1, z_2 \in C_1$, where $i_1^2 = i_2^2 = -1$.
- (iii) The i_3 -conjugate of a bicomplex number $\xi = z_1 + i_2 z_2$ is denoted by ξ' and is defined as $\xi' = \bar{z}_1 - i_2 \bar{z}_2$ for all $z_1, z_2 \in C_1$; here \bar{z}_1 and \bar{z}_2 are the complex conjugates of z_1 and z_2 , respectively, and $i_1^2 = i_2^2 = -1$.

2.2. Partial order relation

Definition 2 [1]. The i_1 -partial order relation \preceq_{i_1} on C_1 is defined as follows: for $z_1, z_2 \in C_1$, $z_1 \preceq_{i_1} z_2$ if and only if $\text{Re}(z_1) \leq \text{Re}(z_2)$ and $\text{Im}(z_1) \leq \text{Im}(z_2)$.

Definition 3. Let $\xi_1, \xi_2 \in C_2$, $\xi_1 = z_1 + i_2 z_2$ and $\xi_2 = z_1^* + i_2 z_2^*$. The i_2 -partial order relation \preceq_{i_2} on C_2 is defined as follows: $\xi_1 \preceq_{i_2} \xi_2$ if and only if $z_1 \preceq_{i_1} z_1^*$ and $z_2 \preceq_{i_1} z_2^*$, i.e., $\xi \preceq_{i_2} \eta$ if one of the following conditions is satisfied:

- (i) $z_1 = z_1^*$ and $z_2 = z_2^*$;
- (ii) $z_1 \prec_{i_1} z_1^*$ and $z_2 = z_2^*$;

- (iii) $z_1 = z_1^*$ and $z_2 \prec_{i_1} z_2^*$;
 (iv) $z_1 \prec_{i_1} z_1^*$ and $z_2 \prec_{i_1} z_2^*$.

In particular, we write $\xi \succ_{i_2} \eta$ if $\xi \preceq_{i_2} \eta$ and $\xi \neq \eta$, i.e., if one of (ii), (iii), and (iv) is satisfied, and we write $\xi \prec_{i_2} \eta$ if only (iv) is satisfied.

For every two bicomplex numbers $\xi, \eta \in C_2$, we can verify the following:

- (1) $\xi \preceq_{i_2} \eta \implies \|\xi\|_{C_2} \leq \|\eta\|_{C_2}$,
 (2) $\|\xi + \eta\|_{C_2} \leq \|\xi\|_{C_2} + \|\eta\|_{C_2}$.

Definition 4. Let $\xi_1, \xi_2 \in C_2$, where

$$\xi_1 = z_1 + i_2 z_2 = \mu_1 e_1 + \mu_2 e_2 \quad \text{and} \quad \xi_2 = z_1^* + i_2 z_2^* = \mu_1^* e_1 + \mu_2^* e_2.$$

The Id -partial order relation $\preceq_{i_{Id}}$ on C_2 is defined as follows: $\xi_1 \preceq_{i_{Id}} \xi_2$ if and only if $\mu_1 \preceq_{i_1} \mu_1^*$ and $\mu_2 \preceq_{i_1} \mu_2^*$ on C_1 , i.e., $\xi \preceq_{i_{Id}} \eta$ if one of the following conditions is satisfied:

- (i) $\mu_1 = \mu_1^*$ and $\mu_2 = \mu_2^*$;
 (ii) $\mu_1 \prec_{i_1} \mu_1^*$ and $\mu_2 = \mu_2^*$;
 (iii) $\mu_1 = \mu_1^*$ and $\mu_2 \prec_{i_1} \mu_2^*$;
 (iv) $\mu_1 \prec_{i_1} \mu_1^*$ and $\mu_2 \prec_{i_1} \mu_2^*$.

In particular, we write $\xi \succ_{i_{Id}} \eta$ if $\xi \preceq_{i_{Id}} \eta$ and $\xi \neq \eta$, i.e., one of (ii), (iii), and (iv) is satisfied, and we write $\xi \prec_{i_{Id}} \eta$ if only (iv) is satisfied.

For every two bicomplex numbers $\xi, \eta \in C_2$, we can verify the following:

$$\xi \preceq_{i_{Id}} \eta \implies \|\xi\|_{C_2} \leq \|\eta\|_{C_2}.$$

Remark 1. For $\xi, \eta \in C_2$, the relation $\xi \prec_{i_2} \eta$ does not guarantee that $\xi \prec_{i_{Id}} \eta$. Similarly, $\xi \prec_{i_{Id}} \eta$ does not guarantee that $\xi \prec_{i_2} \eta$.

2.3. Bicomplex valued metric space

Choi et al. [4] defined a bicomplex valued metric space as follows.

Definition 5 [4]. A function $d : X \times X \rightarrow C_2$ is a bicomplex valued metric on $X \subseteq C_2$ with respect to the i_2 -partial order if it has the following properties for all $x, y, z \in X$:

- (i) $0 \preceq_{i_2} d(x, y)$;
 (ii) $d(x, y) = 0$ if and only if $x = y$;
 (iii) $d(x, y) = d(y, x)$;
 (iv) $d(x, y) \preceq_{i_2} d(x, z) + d(z, y)$.

The pair (X, d) is called a bicomplex valued metric space with respect to the i_2 -partial order. It is denoted by (X, d_{i_2}) .

Definition 6. A function $d : X \times X \rightarrow C_2$ is a bicomplex valued metric on $X \subseteq C_2$ with respect to the i_{Id} -partial order if it has the following properties for all $x, y, z \in X$:

- (i) $0 \preceq_{i_{Id}} d(x, y)$;
 (ii) $d(x, y) = 0$;
 (iii) $d(x, y) = d(y, x)$;
 (iv) $d(x, y) \preceq_{i_{Id}} d(x, z) + d(z, y)$.

The pair (X, d) is called a bicomplex valued metric space with respect to the i_{Id} -partial order. It is denoted by $(X, d_{i_{Id}})$.

Definition 7. A function $d^{\mathcal{H}} : X \times X \rightarrow \mathcal{H}$ is a hyperbolic valued (D -valued) metric on $X \subseteq C_2$ with respect to the i_2 -partial order (the i_{Id} -partial order) if it has the following properties for all $x, y, z \in X$, respectively:

- (i) $0 \preceq_{i_2} (\preceq_{i_{Id}}) d^{\mathcal{H}}(x, y)$;
- (ii) $d^{\mathcal{H}}(x, y) = 0$ if and only if $x = y$;
- (iii) $d^{\mathcal{H}}(x, y) = d^{\mathcal{H}}(y, x)$;
- (iv) $d^{\mathcal{H}}(x, y) \preceq_{i_2} (\preceq_{i_{Id}}) d^{\mathcal{H}}(x, z) + d^{\mathcal{H}}(z, y)$.

The pair $(X, d^{\mathcal{H}})$ is called a bicomplex valued metric space with respect to the i_2 -partial order (the i_{Id} -partial order). The metric space $(X, d^{\mathcal{H}})$ with respect to the i_2 -partial order is denoted by $(X, d_{i_2}^{\mathcal{H}})$, and the metric space $(X, d^{\mathcal{H}})$ with respect to the i_{Id} -partial order is denoted by $(X, d_{i_{Id}}^{\mathcal{H}})$.

2.4. Statistical convergence of a sequences of bicomplex numbers

The concept of statistical convergence depends on the notion of the natural density of the set of natural numbers.

Definition 8. A subset E of \mathbb{N} is said to have natural density $\delta(E)$ if

$$\delta(E) = \lim_{n \rightarrow \infty} \frac{1}{n} \sum_{k=1}^n \chi_E(k),$$

where χ_E is the characteristic function on E .

Definition 9. For two sequences (x_k) and (y_k) , we say that $x_k = y_k$ for almost all k if

$$\delta(\{k \in \mathbb{N} : x_k \neq y_k\}) = 0.$$

Definition 10. A sequence of bicomplex number (ξ_k) is said to be statistically convergent to $\xi \in C_2$ with respect to the Euclidean norm on C_2 if, for all $\varepsilon > 0$,

$$\delta(\{k \in N : \|\xi_k - \xi\|_{C_2} \geq \varepsilon\}) = 0.$$

We use the notation $\text{stat-lim } \xi_k = \xi$.

3. Statistically convergent and statistically Cauchy sequences in a bicomplex valued metric space with respect to the i_2 -partial order

Definition 11. Let (X, d_{i_2}) be a bicomplex valued metric space, and let (ξ_k) be a sequence in (X, d_{i_2}) . The sequence (ξ_k) is said to be statistically convergent to $\xi \in X$ if, for all $0 \prec_{i_2} \varepsilon \in C_2$,

$$\delta(\{k : d(\xi_k, \xi) \succeq_{i_2} \varepsilon\}) = 0.$$

We use the notation $\text{stat-lim } \xi_k = \xi$.

Definition 12. Let (X, d_{i_2}) be a bicomplex valued metric space, and let (ξ_k) be a sequence in (X, d_{i_2}) . We say that (ξ_k) is a statistically Cauchy sequence if, for all $0 \prec_{i_2} \varepsilon \in X$,

$$\delta(\{k : d(\xi_k, \xi_m) \succeq_{i_2} \varepsilon\}) = 0.$$

Definition 13. Let (X, d_h) be a D -valued metric space, and let (ξ_k) be a sequence in (X, d_h) . The sequence (ξ_k) is said to be statistically convergent to $\xi \in X$ if, for all $0 \prec_{i_2} \varepsilon \in D$,

$$\delta(\{k : d_h(\xi_k, \xi) \succeq_{i_2} \varepsilon\}) = 0.$$

4. Main results

Lemma 1. *If a sequence (ξ_k) is statistically convergent in a bicomplex valued metric space (X, d_{i_2}) , then $(d(\xi_k, \xi))$ is statistically convergent to 0 with respect to Euclidean norm on C_2 .*

P r o o f. Since (ξ_k) is statistically convergent in a bicomplex valued metric space (X, d_{i_2}) , for all $\varepsilon \succ_{i_2} 0$, we have

$$\begin{aligned} \delta(\{k : d(\xi_k, \xi) \succeq_{i_2} \varepsilon\}) = 0 &\implies \delta(\{k : \|d(\xi_k, \xi)\|_{C_2} \geq \|\varepsilon\|_{C_2}\}) = 0 \\ &\implies \delta(\{k : \|d(\xi_k, \xi)\|_{C_2} \geq \varepsilon'\}) = 0, \end{aligned}$$

where $\varepsilon' = \|\varepsilon\|_{C_2} > 0$. Thus, the sequences of bicomplex numbers $(d(\xi_k, \xi))$ is statistically convergent to 0 with respect to the Euclidean norm on C_2 , and hence $\text{stat-lim } d(\xi_k, \xi) = 0$. \square

Lemma 2. *Let (X, d_{i_2}) be a bicomplex valued metric space, then the inequality*

$$d(\xi_1, \eta_1) - d(\xi_2, \eta_2) \preceq_{i_2} d(\xi_1, \xi_2) + d(\eta_1, \eta_2)$$

holds for all $\xi_1, \xi_2, \eta_1, \eta_2 \in C_2$.

P r o o f. By the triangle inequality, we have

$$\begin{aligned} d(\xi_1, \eta_1) \preceq_{i_2} d(\xi_1, \xi_2) + d(\xi_2, \eta_2) + d(\eta_2, \eta_1) &\implies d(\xi_1, \eta_1) - d(\xi_2, \eta_2) \preceq_{i_2} d(\xi_1, \xi_2) + d(\eta_2, \eta_1) \\ &\implies d(\xi_1, \eta_1) - d(\xi_2, \eta_2) \preceq_{i_2} d(\xi_1, \xi_2) + d(\eta_1, \eta_2). \end{aligned}$$

\square

Theorem 1. *Let (X, d_{i_2}) be a bi-complex valued metric space, and if the sequences (ξ_k) and (η_k) are statistically convergent to ξ and η , respectively, in (X, d_{i_2}) . Then the sequence $(d(\xi_k, \eta_k))$ is statistically convergent to $d(\xi, \eta)$ with respect to Euclidean norm in C_2 .*

P r o o f.

$$\begin{aligned} \{k : d(\xi_k, \eta_k) - d(\xi, \eta) \succeq_{i_2} \varepsilon\} &\subseteq \{k : d(\xi_k, \xi) \succeq_{i_2} \varepsilon\} \cup \{k : d(\eta_k, \eta) \succeq_{i_2} \varepsilon\} \\ \implies \delta(\{k : d(\xi_k, \eta_k) - d(\xi, \eta) \succeq_{i_2} \varepsilon\}) &\leq \delta(\{k : d(\xi_k, \xi) \succeq_{i_2} \varepsilon\}) + \delta(\{k : d(\eta_k, \eta) \succeq_{i_2} \varepsilon\}) \\ &\implies \delta(\{k : d(\xi_k, \eta_k) - d(\xi, \eta) \succeq_{i_2} \varepsilon\}) = 0 \\ &\implies \delta(\{k : \|d(\xi_k, \eta_k) - d(\xi, \eta)\|_{C_2} \geq \|\varepsilon\|_{C_2}\}) = 0. \end{aligned}$$

\square

Let us formulate the following theorem without proof.

Theorem 2. *Let (X, d_{i_2}) be a bicomplex valued metric space, and let $\xi, \eta \in X$. If (ξ_k) is a sequence in X statistically convergent to ξ and statistically convergent to η , then $\xi = \eta$.*

Lemma 3. *Consider a bicomplex valued metric space (X, d_{i_2}) on C_2 . Suppose that*

$$d(\xi_k, \xi) = d_1(\xi_k, \xi) + i_1 d_2(\xi_k, \xi) + i_2 d_3(\xi_k, \xi) + i_1 i_2 d_4(\xi_k, \xi).$$

The sequence (ξ_k) is statistically convergent (statistically Cauchy) in (X, d_{i_2}) if and only if (x_k) is statistically convergent (statistically Cauchy) in the real valued metric spaces (X, d_j) , $j = 1, 2, 3, 4$.

Lemma 4. Consider a bicomplex valued metric space (X, d_{i_2}) on X . Suppose that

$$d(\xi_k, \xi) = d_1(\xi_k, \xi) + i_1 d_2(\xi_k, \xi) + i_2 d_3(\xi_k, \xi) + i_1 i_2 d_4(\xi_k, \xi).$$

Then A sequence (ξ_k) , where

$$\xi_k = x_1 + i_1 x_2 + i_2 x_3 + i_1 i_2 x_4, \quad x_1, x_2, x_3, x_4 \in C_0,$$

is statistically convergent (statistically Cauchy) in (X, d_{i_2}) if and only if (x_j) is statistically convergent (statistically Cauchy) in the real valued metric spaces (C_2, d_j) , $j = 1, 2, 3, 4$.

Lemma 5. Consider a D -valued metric space $(X, d_{i_2}^{\mathcal{H}})$ on X . Suppose that

$$d^{\mathcal{H}}(\xi_k, \xi) = d_1^{\mathcal{H}}(\xi_k, \xi)e_1 + d_2^{\mathcal{H}}(\xi_k, \xi)e_2.$$

Then $(X, d_1^{\mathcal{H}})$ and $(X, d_2^{\mathcal{H}})$ are real valued metric spaces. A sequence (ξ_k) is statistically convergent (statistically Cauchy) in $(X, d^{\mathcal{H}})$ with respect to the i_2 -partial order if and only if (ξ_k) is statistically convergent (statistically Cauchy) in the real valued metric spaces $(X, d_j^{\mathcal{H}})$, $j = 1, 2$.

Lemma 6. Consider a D -valued metric space $(\mathcal{H}, d_{i_2}^{\mathcal{H}})$ on \mathcal{H} . Suppose that

$$d^{\mathcal{H}}(\xi_k, \xi) = d_1^{\mathcal{H}}(\xi_k, \xi)e_1 + d_2^{\mathcal{H}}(\xi_k, \xi)e_2.$$

Then $(C_2, d_1^{\mathcal{H}})$ and $(C_2, d_2^{\mathcal{H}})$ are real valued metric spaces. A sequence $(\xi_k) \in \mathcal{H}$, where

$$\xi_k = \mu_{1k}e_1 + \mu_{2k}e_2,$$

is statistically convergent (statistically Cauchy) in $(\mathcal{H}, d^{\mathcal{H}})$ with respect to the i_2 -partial order if and only if (μ_{jk}) is statistically convergent (statistically Cauchy) in the real valued metric spaces $(C_2, d_j^{\mathcal{H}})$, $j = 1, 2$.

Theorem 3. If (ξ_k) and (η_k) are statistically convergent in a bicomplex valued metric space (X, d_{i_2}) and if

$$\|d_1(\xi_k, \eta_k)\| \leq \|d(\xi_k, \eta_k)\|$$

for all $k \in \mathbb{N}$, then $(d_1(\xi_k, \eta_k))$ is also statistically convergent with respect to the Euclidean norm in C_2 .

P r o o f. Using Lemma 2, for all $\varepsilon \succ_{i_2} 0$ and $k, m \geq n_0$, we obtain

$$\begin{aligned} \{k : d_1(\xi_k, \eta_k) - d_1(\xi_m, \eta_m) \succeq_{i_2} \varepsilon\} &\subseteq \{k : d_1(\xi_k, \xi_m) \succeq_{i_2} \varepsilon\} \cup \{k : d_1(\eta_k, \eta_m) \succeq_{i_2} \varepsilon\} \\ &\implies \{k : \|d_1(\xi_k, \eta_k) - d_1(\xi_m, \eta_m)\|_{C_2} \geq \|\varepsilon\|_{C_2}\} \\ &\leq \{k : \|d_1(\xi_k, \xi_m)\|_{C_2} \geq \|\varepsilon\|_{C_2}\} \cup \{k : \|d_1(\eta_k, \eta_m)\|_{C_2} \geq \|\varepsilon\|_{C_2}\} \\ &\implies \delta(\{k : \|d_1(\xi_k, \eta_k) - d_1(\xi_m, \eta_m)\|_{C_2} \geq \|\varepsilon\|_{C_2}\}) \\ &\leq \delta(\{k : \|d_1(\xi_k, \xi_m)\|_{C_2} \geq \|\varepsilon\|_{C_2}\}) \cup \delta(\{k : \|d_1(\eta_k, \eta_m)\|_{C_2} \geq \|\varepsilon\|_{C_2}\}) \\ &\implies \delta(\{k : \|d_1(\xi_k, \eta_k) - d_1(\xi_m, \eta_m)\|_{C_2} \geq \|\varepsilon\|_{C_2}\}) = 0. \end{aligned}$$

Thus, $(d_1(\xi_k, \eta_k))$ is a Cauchy sequence of bicomplex numbers and, hence, $(d_1(\xi_k, \eta_k))$ is statistically convergent with respect to the Euclidean norm. \square

Lemma 7. $\delta(\{k : d(\xi_k, \xi) \succeq_{i_2} \varepsilon\}) = 0$ implies that $\delta(\{k : d(\xi_k, \xi_m) \succeq_{i_2} \varepsilon\}) = 0$.

P r o o f.

$$\delta(\{k : d(\xi_k, \xi) \succeq_{i_2} \varepsilon\}) = 0 \implies \delta(\{k : d(\xi_k, \xi) \prec_{i_2} \varepsilon/2\}) = 1 \implies \delta(\{k : d(\xi_m, \xi) \prec_{i_2} \varepsilon/2\}) = 1.$$

We have

$$\begin{aligned} \{k : d(\xi_k, \xi) \prec_{i_2} \varepsilon/2\} &\subseteq \{k : d(\xi_k, \xi_m) \prec_{i_2} \varepsilon\} \implies \delta(\{k : d(\xi_k, \xi_m) \prec_{i_2} \varepsilon\}) = 1 \\ &\implies \delta(\{k : d(\xi_k, \xi_m) \succeq_{i_2} \varepsilon\}) = 0. \end{aligned}$$

□

Remark 2. The converse is generally not true. To justify this, consider the following example.

Example 1. Let

$$X = (0, 1 + i_1 + i_2 + i_1 i_2]$$

with the metric

$$d(\xi, \eta) = (1 + i_1 + i_2) \|\xi - \eta\|_{C_2}$$

for all $\xi, \eta \in X$.

Consider a sequence (ξ_k) in X defined as

$$\xi_k = \begin{cases} \frac{(1 + i_1 + i_2 + i_1 i_2)}{k} & \text{for } k = i^2, \quad i \in \mathbb{N}; \\ \frac{(1 + i_1 + i_2 + i_1 i_2)}{k^2} & \text{otherwise.} \end{cases}$$

Then, we observe that (ξ_k) is a statistically Cauchy sequence but is not statistically convergent in X .

Lemma 8. Let (X, d_{i_2}) be a complete bicomplex valued metric space, and let (ξ_k) be a sequence in X . Then the following properties are equivalent:

- (i) (ξ_k) is statistically convergent;
- (ii) (ξ_k) is a statistically Cauchy sequence.

Theorem 4. Assume that (ξ_k) is a sequence in a bicomplex valued metric space (X, d_{i_2}) and

$$\delta(\{k : \sum_{i=1}^k d(\xi_i, \xi_{i+1}) \succeq_{i_2} \varepsilon\}) = 0.$$

Then (ξ_k) is a statistically Cauchy sequence in (X, d_{i_2}) .

P r o o f. We have

$$\begin{aligned} \delta(\{k : \sum_{i=1}^k d(\xi_i, \xi_{i+1}) \succeq_{i_2} \varepsilon\}) &= 0 \\ \implies \delta(\{k : \sum_{i=1}^k d_j(\xi_i, \xi_{i+1}) \geq \varepsilon_j\}) &= 0, \quad j = 1, 2, 3, 4 \\ \implies \delta(\{k : d_j(\xi_k, \xi_{k+1}) \geq \varepsilon_j\}) &= 0, \quad j = 1, 2, 3, 4. \end{aligned}$$

Thus, (ξ_k) is a statistically Cauchy sequence in the real valued metric spaces (X, d_j) , $j = 1, 2, 3, 4$. Hence, (ξ_k) is a statistically Cauchy sequence in the bicomplex valued metric space (X, d_{i_2}) . □

Theorem 5. Let (ξ_k) , where

$$\xi_k = z_{1k} + i_2 z_{2k},$$

be a sequence of bicomplex numbers in the bicomplex valued metric space (X, d_{i_2}) . Then the following properties are equivalent:

- (i) (ξ_k) statistically converges to a point $\xi = z_1 + i_2 z_2 \in X$;
- (ii) (z_{1k}) and (z_{2k}) statistically converge to z_1 and z_2 , respectively;
- (iii) there are sequences (z_{1k}) and (z_{2k}) such that $z_{1k} = z'_{1k}$ and $z_{2k} = z'_{2k}$ for almost all k and (z'_{1k}) and (z'_{2k}) converge to z_1 and z_2 , respectively;
- (iv) there is a bicomplex sequence convergent to $\xi + i_2 \bar{\xi}$, where $\bar{\xi}$ is the i_2 -conjugate of ξ ;
- (v) there are a statistically dense subsequence (z_{1k_i}) of (z_{1k}) and a statistically dense subsequence (z_{2k_i}) of (z_{2k}) such that (z_{1k_i}) and (z_{2k_i}) are convergent;
- (vi) there are a statistically dense subsequence (z_{1k_i}) of (z_{1k}) and a statistically dense subsequence (z_{2k_i}) of (z_{2k}) such that (z_{1k_i}) and (z_{2k_i}) are statistically convergent.

P r o o f. (i) \implies (ii) The sequence (ξ_k) is statistically convergent to ξ . Then for every

$$0 \prec \varepsilon = \varepsilon_1 + i_2 \varepsilon_2 \in C_2,$$

we have

$$\delta(\{k : d_{i_2}(\xi_k, \xi) \succeq_{i_2} \varepsilon\}) = \lim_{n \rightarrow \infty} \frac{1}{n} |\{k : d_{i_2}(\xi_k, \xi) \succeq_{i_2} \varepsilon\}| = 0.$$

There are two following cases.

Case 1. Consider

$$d_{i_2}(\xi_k, \xi) = |z_{1k} - z_1| + i_2 |z_{2k} - z_2|$$

or

$$d_{i_2}(\xi_k, \xi) = d_1(z_{1k}, z_1) + i_2 d_1(z_{2k}, z_2),$$

where

$$d_1(z_k, z) = |z_k - z|,$$

corresponds to a real valued metric space on C_1 with the property

$$\{k : d_{i_2}(\xi_k, \xi) \succeq_{i_2} \varepsilon\} = \{k : |z_{1k} - z_1| + i_2 |z_{2k} - z_2| \succeq_{i_2} (\varepsilon_1 + i_2 \varepsilon_2)\}.$$

We have

$$\delta(\{k : |z_{1k} - z_1| \geq |\varepsilon_1|\}) \leq \delta(\{k : d_{i_2}(\xi_k, \xi) \succeq_{i_2} \varepsilon\}) = 0,$$

which implies

$$\delta(\{k : |z_{1k} - z_1| \geq |\varepsilon|\}) = 0.$$

Similarly,

$$\delta(\{k : |z_{2k} - z_2| \geq |\varepsilon|\}) = 0.$$

Hence, (z_{1n}) and (z_{2n}) are statistically convergent in real valued metric spaces on C_1 .

Case 2. Consider

$$d_{i_2}(\xi_k, \xi) = (a_1 + i_2 a_2) \|\xi_k - \xi\|_{C_2},$$

where

$$0 \prec a_1, a_2 \in C_1(i_1),$$

or

$$d_{i_2}(\xi_k, \xi) = a_1 \|\xi_k - \xi\|_{C_2} + i_2 a_2 \|\xi_k - \xi\|_{C_2}$$

or

$$d_{i_2}(\xi_k, \xi) = a_1 d_1(\xi_k, \xi) + i_2 a_2 d_1(\xi_k, \xi),$$

where

$$d_1(\xi_k, \xi) = \|\xi_k - \xi\|_{C_2},$$

defines a real valued metric space on C_2 . Then, (ξ_k) is statistically convergent in real valued metric space on C_2 .

We have

$$\|\xi_k - \xi\|_{C_2} = \sqrt{(z_{1k} - z_1)^2 + (z_{2k} - z_2)^2} = d_2^2(z_{1k}, z_1) + d_2^2(z_{2k}, z_2),$$

and

$$|z_{1k} - z_1| \leq \sqrt{(z_{1k} - z_1)^2 + (z_{2k} - z_2)^2},$$

which implies that

$$\{k : |z_{1k} - z_1| \geq \varepsilon\} \subseteq \{k : d_1(\xi_k, \xi) \geq \varepsilon\}.$$

Hence, (z_{1k}) is statistically convergent in a related real valued metric space. Similarly, (z_{2k}) is statistically convergent in a real valued metric space.

(ii) \implies (iii) The sequences (z_{1k}) and (z_{2k}) statistically converge to z_1 and z_2 , respectively. Then, for every $0 < \varepsilon \in C_0$, we have

$$\delta(\{k : d(z_{1k}, z_1) \geq \varepsilon\}) = \lim_{n \rightarrow \infty} \frac{1}{n} |\{k : d(z_{1k}, z_1) \geq \varepsilon\}| = 0$$

and

$$\delta(\{k : d(z_{2k}, z_2) \geq \varepsilon\}) = \lim_{n \rightarrow \infty} \frac{1}{n} |\{k : d(z_{2k}, z_2) \geq \varepsilon\}| = 0.$$

Choose an increasing sequence of natural numbers (n_k) such that, for all $n > n_k$,

$$\frac{1}{n} |\{k : d(z_{1k}, z) \geq \frac{1}{2^k}\}| < \frac{1}{2^k}.$$

Define a sequence of complex numbers (w_{1k}) such that

$$w_{1k} = \begin{cases} z_{1k} & \text{if } k \leq n_1; \\ z_{1k} & \text{if } d(z_{1k}, z) \geq \frac{1}{2^k}; \\ z_1 & \text{otherwise.} \end{cases}$$

The sequence (w_{1k}) is convergent.

Now we have

$$\{k : z_{1k} = w_{1k}\} \supseteq \{k : d_{i_1}(z_{1k}, z_1) \prec_{i_1} \varepsilon\}.$$

Therefore, $z_{1k} = w_{1k}$ for almost all k . Similarly, $z_{2k} = w_{2k}$ for almost all k .

(iii) \implies (iv) The sequences (z_{1k}) and (z_{2k}) converge to z_1 and z_2 , respectively. Then the bicomplex sequence $(\xi_k) = (z_{1k} + i_2 z_{2k})$ converges to $\xi = z_1 + i_2 z_2$ and the bicomplex sequence $(\zeta_k) = (z_{2k} + i_2 z_{1k})$ converges to $z_2 + i_2 z_1$, i.e., to $i_2 \bar{\xi}$. Hence, there exists a bicomplex sequence $(\eta_k) = (\xi_k + \zeta_k)$ converging to $\xi + i_2 \bar{\xi}$.

(iv) \implies (v) Consider a bicomplex sequence (η_k) converging to

$$\xi + i_2 \bar{\xi} = (z_1 + z_2) + i_2(z_1 + z_2).$$

Let

$$\eta_k = z'_{1k} + i_2 z'_{2k}.$$

There exist (z''_{1k}) and (z''_{2k}) such that

$$z'_{1k} = z_{1k} + z''_{1k} \quad \text{and} \quad z'_{2k} = z_{2k} + z''_{2k},$$

and as (z_{1k}) and (z_{2k}) are convergent we have

$$\lim_{k \rightarrow \infty} z''_{1k} = z_2 \quad \text{and} \quad \lim_{k \rightarrow \infty} z''_{2k} = z_1.$$

Let

$$M_1 = \{k : d_{i_1}(z''_{1k}, z_2) \succeq_{i_1} \varepsilon\} \quad \text{and} \quad M_2 = \{k : d_{i_1}(z''_{2k}, z_1) \succeq_{i_1} \varepsilon\}.$$

Let

$$K_1 = \mathbb{N} - M_1 = \{k_i : k_i < k_{i+1}\} \quad \text{and} \quad K_2 = \mathbb{N} - M_2 = \{k'_i : k'_i < k'_{i+1}\}.$$

Then $\delta(K_1) = 1$ and $\delta(K_2) = 1$. Thus, we have

$$\lim_{i \rightarrow \infty} z_{1k_i} = z_1 \quad \text{and} \quad \lim_{i \rightarrow \infty} z_{2k_i} = z_2.$$

(v) \implies (vi) A subsequence (z_{1k_i}) of the sequence (z_{1k}) is convergent, hence, it is statistically convergent. Similarly, (z_{2k_i}) is statistically convergent.

(vi) \implies (i) Let there exist

$$K_1 = \{k_i : k_i < k_{i+1}\} \subset \mathbb{N} \quad \text{and} \quad K_2 = \{k'_i : k'_i < k'_{i+1}\} \subset \mathbb{N}$$

such that

$$\lim_{i \rightarrow \infty} z_{1k_i} = z_1 \quad \text{and} \quad \lim_{i \rightarrow \infty} z_{2k_i} = z_2.$$

Then, for all

$$0 \prec_{i_2} \varepsilon = \varepsilon_1 + i_2 \varepsilon_2 \in C_2,$$

we have

$$\begin{aligned} \{k : d_{i_2}(\xi_k, \xi) \succeq_{i_2} \varepsilon\} &\subseteq \{k : d_{i_1}(z_{1k}) \succeq_{i_1} \varepsilon_1\} \cup \{k : d_{i_1}(z_{2k}) \succeq_{i_1} \varepsilon_2\} \\ &\subseteq K_1^c \cup \{k \in K_1 : d_{i_1}(z_{1k}, z_1) \succeq_{i_1} \varepsilon_1\} \cup K_2^c \cup \{k \in K_2 : d_{i_1}(z_{2k}, z_2) \succeq_{i_1} \varepsilon_2\}. \end{aligned}$$

Therefore, (ξ_k) is statistically convergent. □

5. Statistically convergent and statistically Cauchy sequences in a bicomplex valued metric space with respect to the i_{Id} -partial order

Definition 14. Let $(X, d_{i_{Id}})$ be a bicomplex valued metric space, and let (ξ_k) be a sequence in (X, d) . The sequence (ξ_k) is said to be statistically convergent to $\xi \in X$ if, for all $0 \prec_{i_{Id}} \varepsilon \in C_2$,

$$\delta(\{k : d(\xi_k, \xi) \succeq_{i_{Id}} \varepsilon\}) = 0.$$

We use the notation $\text{stat-lim } \xi_k = \xi$.

Definition 15. Let $(X, d_{i_{Id}})$ be a bicomplex valued metric space, and let (ξ_k) be a sequence in $(X, d_{i_{Id}})$. We say that (ξ_k) is a statistically Cauchy sequence if, for all $0 \prec_{i_{Id}} \varepsilon \in C_2$,

$$\delta(\{k : d(\xi_k, \xi_m) \succeq_{i_{Id}} \varepsilon\}) = 0.$$

Example 2. Consider a metric $d : C_2 \times C_2 \rightarrow C_2$ on C_2 defined as

$$d(\xi, \eta) = [(5 + 8i_1)e_1 + (7 + 2i_1)e_2] \|\xi - \eta\|_{C_2} \quad \forall \xi, \eta \in C_2.$$

Consider a sequence (ξ_k) in C_2 defined as

$$\xi_k = \begin{cases} 1 + i_1 + i_2 + i_1i_2 & \text{for } k = i^2, \quad i \in \mathbb{N}; \\ 1/2022 & \text{otherwise.} \end{cases}$$

Then we observe that (ξ_k) is statistically convergent in the metric space (C_2, d_{i_1d}) .

Lemma 9. Consider a bicomplex valued metric space (X, d_{i_1d}) on X . Suppose that

$$d(\xi_k, \xi) = d'_1(\xi_k, \xi)e_1 + d'_2(\xi_k, \xi)e_2.$$

Then (X, d'_1) and (X, d'_2) are complex valued metric spaces. A sequence (ξ_k) is statistically convergent (statistically Cauchy) in (X, d_{i_1d}) if and only if (ξ_k) is a statistically convergent (statistically Cauchy) sequence in the complex valued metric spaces (X, d'_j) , $j = 1, 2$.

Lemma 10. Consider a bicomplex valued metric space (X, d_{i_1d}) on X . Suppose that

$$d(\xi_k, \xi) = d'_1(\xi_k, \xi)e_1 + d'_2(\xi_k, \xi)e_2.$$

Then (X, d'_1) and (X, d'_2) are complex valued metric spaces. A sequence (ξ_k) , where

$$\xi_k = \mu_{1k}e_1 + \mu_{2k}e_2,$$

is a statistically convergent (statistically Cauchy) sequence in (X, d_{i_1d}) if and only if (μ_{jk}) are statistically convergent (statistically Cauchy) sequences in the complex valued metric spaces (X, d'_j) , $j = 1, 2$.

We formulate the following theorem without proof.

Theorem 6. Let (ξ_k) , where

$$\xi_k = \mu_{1k}e_1 + \mu_{2k}e_2,$$

be a sequence of bicomplex numbers in the bicomplex valued metric space (X, d_{i_1d}) . Then the following statements are equivalent:

- (i) (ξ_k) statistically converges to a point $\xi = \mu_1e_1 + \mu_2e_2 \in X$;
- (ii) (μ_{1k}) and (μ_{2k}) statistically converge to μ_1 and μ_2 , respectively;
- (iii) there are sequences (μ_{1k}) and (μ_{2k}) such that $\mu_{1k} = \mu'_{1k}$ and $\mu_{2k} = \mu'_{2k}$ for almost all k , and (μ'_{kn}) and (μ'_{2k}) converge to μ_1 and μ_2 , respectively;
- (iv) there is a bicomplex sequence converging to $\mu_1 + \mu_2 - (i_2 - 1)(\mu_1e_2 + \mu_2e_1)$;
- (v) there are a statistically dense subsequence (μ_{1k_i}) of (μ_{1k}) and a statistically dense subsequence (μ_{2k_i}) of (μ_{2k}) such that (μ_{1k_i}) and (μ_{2k_i}) are convergent;
- (vi) there are a statistically dense subsequence (μ_{1k_i}) of (μ_{1k}) and a statistically dense subsequence (μ_{2k_i}) of (μ_{2k}) such that (μ_{1k_i}) and (μ_{2k_i}) are statistically convergent.

Theorem 7. $(X, d_{i_{1d}})$ is complete if and only if (X, d') and (X, d'') are complete metric spaces in C_1 , where

$$d(\xi, \eta) = d'(\xi, \eta)e_1 + d''(\xi, \eta)e_2.$$

P r o o f. Let $(X, d_{i_{1d}})$ be a complete metric space, and let $\xi = (\xi_k)$ be a Cauchy sequence in (X, d') . Therefore, for all $0 \prec_{i_2} \varepsilon' \in C_1$, there exists $k_0 \in \mathbb{N}$ such that

$$d'(\xi_k, \xi_m) \prec_{i_1} \varepsilon' \quad \forall k, m \geq k_0.$$

Consider

$$d(\xi_k, \xi_m) = d'(\xi_k, \xi_m)e_1 + 0 \cdot e_2 \in C_2 \quad \text{and} \quad \varepsilon = \varepsilon'e_1 + 0 \cdot e_2 \in C_2.$$

Then

$$d(\xi_k, \xi_m) = d'(\xi_k, \xi_m)e_1 + 0 \cdot e_2 \prec_{i_{1d}} \varepsilon_1 \varepsilon + 0 \cdot e_2.$$

This implies that (ξ_k) is a Cauchy sequence in $(X, d_{i_{1d}})$. Therefore, by the completeness of $(X, d_{i_{1d}})$, there exists ξ in $(X, d_{i_{1d}})$ such that $\xi_k \rightarrow \xi$ as $n \rightarrow \infty$ in $(X, d_{i_{1d}})$. We need to show that $\xi_k \rightarrow \xi'$ as $n \rightarrow \infty$ in (X, d') and $x'' = 0$.

Now, $\xi_k \rightarrow \xi$ as $n \rightarrow \infty$ in $(X, d_{i_{1d}})$, therefore, there exists a natural number k such that

$$\begin{aligned} d(\xi_k, \xi) &\prec_{i_{1d}} \varepsilon \quad \text{for all } n > k \\ \implies d'(\xi_k, \xi)e_1 + 0 \cdot e_2 &\prec_{i_{1d}} \varepsilon'e_1 + 0 \cdot e_2 \quad \text{for all } n > k \\ \implies d'(\xi_k, \xi) &\prec_{i_1} \varepsilon' \quad \text{for all } n > k. \end{aligned}$$

Similarly, $d''(\xi_k, \xi) \prec_{i_1} \varepsilon'$ for all $n > k$. Hence, (X, d') and (X, d'') are complete metric spaces in C_1 .

Conversely, let (X, d') and (X, d'') be complete metric spaces in $C(i_1)$.

Let (ξ_k) be a Cauchy sequence in $(X, d_{i_{1d}})$. Therefore, for $\varepsilon \succ_{i_{1d}} 0$, there exists $k_0 \in \mathbb{N}$ such that $\forall m, k \geq k_0$

$$\begin{aligned} d_{i_{1d}}(\xi_k, \xi_m) \prec_{i_{1d}} \varepsilon &\implies d'(\xi_k, \xi_m)e_1 + d''(\xi_k, \xi_m)e_2 \prec_{i_{1d}} \varepsilon'e_1 + \varepsilon''e_2 \\ &\implies d'(\xi_k, \xi_m) \prec_{i_1} \varepsilon' \quad \text{and} \quad d''(\xi_k, \xi_m) \prec_{i_1} \varepsilon''. \end{aligned}$$

Therefore, (ξ_k) is a Cauchy sequence in (X, d') and (X, d'') .

Since (X, d') and (X, d'') are complete, there exist $k'_0, k''_0 \in \mathbb{N}$ such that

$$d'(\xi_k, \xi) \prec_{i_1} \varepsilon' \quad \text{for all } k > k'_0 \quad \text{and} \quad d''(\xi_k, \xi) \prec_{i_1} \varepsilon'' \quad \text{for all } k > k''_0.$$

Now, for all $k > k_1 = \max\{k'_0, k''_0\}$,

$$\begin{aligned} d(\xi_k, \xi) &= d'(\xi_k, \xi)e_1 + d''(\xi_k, \xi)e_2 \prec_{i_{1d}} \varepsilon'e_1 + \varepsilon''e_2 \\ &\implies d(\xi_k, \xi) \prec_{i_{1d}} \varepsilon, \quad \text{where } \varepsilon = \varepsilon'e_1 + \varepsilon''e_2 \in C_2. \end{aligned}$$

Hence, $(X, d_{i_{1d}})$ is a complete metric space. □

We formulate the following theorem without proof.

Theorem 8. Let $(C_2, d_{i_{1d}})$ be a bicomplex valued metric space. Then the class b_∞^* of all bounded statistically convergent sequences of bicomplex numbers over C_2 is complete.

Theorem 9. The metric spaces (X, d_{i_2}) and $(X, d_{i_{1d}})$ are not comparable.

P r o o f. Consider a metric $d : X \times X \rightarrow C_2$ on X defined as

$$d(\xi, \eta) = (5 + 6i_1 + 7i_2 + i_1i_2)\|\xi - \eta\|_{C_2} \quad \forall \xi, \eta \in X.$$

Then, all properties of metric space with respect to the i_2 -partial order holds and hence (X, d_{i_2}) is a metric space. Now we have

$$\begin{aligned} d(\xi, \eta) &= (5 + 6i_1 + 7i_2 + i_1i_2)\|\xi - \eta\|_{C_2} \\ &= [(-2 + 5i_1)e_1 + (12 + 7i_1)e_2]\|\xi - \eta\|_{C_2} \quad \forall \xi, \eta \in X. \end{aligned}$$

Then the property $d(\xi, \eta) \succ 0$ with respect to the Id -partial order does not hold. Therefore, $(X, d_{i_{Id}})$ is not a metric space.

Next, consider a metric $d : X \times X \rightarrow C_2$ on X defined as

$$d(\xi, \eta) = [(5 + 8i_1)e_1 + (7 + 2i_1)e_2]\|\xi - \eta\|_{C_2} \quad \forall \xi, \eta \in X.$$

Then all properties of metric space with respect to the Id -partial order hold and hence $(X, d_{i_{Id}})$ is a metric space. Now we have

$$\begin{aligned} d(\xi, \eta) &= [(5 + 8i_1)e_1 + (7 + 2i_1)e_2]\|\xi - \eta\|_{C_2} \\ &= (6 + 5i_1 - 3i_2 - i_1i_2)\|\xi - \eta\|_{C_2} \quad \forall \xi, \eta \in X. \end{aligned}$$

Then the property $d(\xi, \eta) \succ 0$ with respect to the i_2 -partial order does not hold. Therefore, (X, d_{i_2}) is not a metric space. \square

6. Complete bicomplex metric space

Definition 16. A bicomplex valued metric space on C_2 is said to be a complete bicomplex metric space if every Cauchy sequence of bicomplex numbers in C_2 converges to a point in C_2 .

Theorem 10. Let (C_2, d_{i_2}) be a bicomplex valued metric space. Then the class b_∞^* of all bounded statistically convergent sequences of bicomplex numbers over C_2 is complete.

P r o o f. Let (ξ_k) be a Cauchy sequence of bicomplex numbers in b_∞^* . For a given $0 \prec_{i_2} \varepsilon \in C_2$, there exists $n_0 \in \mathbb{N}$ such that

$$\sup_k d(\xi_k^m, \eta_k^n) \prec_{i_2} \varepsilon \quad \forall m, n \geq n_0.$$

Then, for every fixed value of k ,

$$d(\xi_k^m, \eta_k^n) \prec_{i_2} \frac{\varepsilon}{3} \quad \text{for all } m, n \geq n_0. \quad (6.1)$$

Then (ξ_k^j) is a bicomplex Cauchy sequence in (C_2, d_{i_2}) . Since (C_2, d_{i_2}) is a complete bicomplex metric space, (ξ_k^j) converges to $\xi \in C_2$ for all $k \in \mathbb{N}$.

Let

$$\lim_{k \rightarrow \infty} \xi_k^m = \xi.$$

Let (ξ_k^j) statistically converge to $\eta^m \in X$ for all j . Then

$$\delta\left(\left\{k \in \mathbb{N} : d(\xi_k^j, \eta^j) \prec_{i_2} \frac{\varepsilon}{3}\right\}\right) = 1.$$

Let

$$A_j = \left\{ k \in \mathbb{N} : d(\xi_k^j, \eta^j) \prec_{i_2} \frac{\varepsilon}{3} \right\}. \quad (6.2)$$

Let n_0 be chosen such that for $k \in A_j \cap A_r$ for all $j, r \geq n_0$. Now,

$$\begin{aligned} d(\eta^j, \eta^r) &\prec_{i_2} d(\xi_k^j, \xi_k^r) + d(\xi_k^r, \eta^r) + d(\xi_k^j, \eta^j) \\ \implies d(\eta^j, \eta^r) &\prec_{i_2} \frac{\varepsilon}{3} + \frac{\varepsilon}{3} + \frac{\varepsilon}{3} \quad [\text{using (6.1) and (6.2)}] \\ &\implies d(\eta^j, \eta^r) \prec_{i_2} \varepsilon. \end{aligned}$$

Hence, (η^j) is a Cauchy sequence in (C_2, d_{i_2}) , which is complete. Let

$$\lim_{j \rightarrow \infty} \eta^j = \eta.$$

Now,

$$d(\xi_k, \eta) \prec_{i_2} d(\xi_k^j, \xi_k) + d(\eta^j, \eta) + d(\xi_k^j, \eta^j) \prec_{i_2} \varepsilon,$$

as $\delta(A_j) = 1$ implies that,

$$\delta(\{k : d(\xi_k, \eta) \prec_{i_2} \varepsilon\}) = 1.$$

Hence, b_∞^* is a complete bicomplex metric space. This completes the proof. \square

7. Conclusion

In this paper, we have studied the statistical convergence in bicomplex valued metric spaces. This is the first paper on this topic and is expected to attract researchers for further investigations and applications.

REFERENCES

1. Azam A., Fisher B. and Khan M. Common fixed point theorems in complex valued metric spaces. *Numer. Funct. Anal. Optim.*, 2011. Vol. 32, No. 3. P. 243–253. DOI: [10.1080/01630563.2011.533046](https://doi.org/10.1080/01630563.2011.533046)
2. Buck R. C. Generalized asymptotic density. *Amer. J. Math.*, 1953. Vol. 75, No. 2. P. 335–346. DOI: [10.2307/2372456](https://doi.org/10.2307/2372456)
3. Beg I., Datta S. K., Pal D. Fixed point in bicomplex valued metric spaces. *Int. J. Nonlinear Anal. Appl.*, 2021. Vol. 12, No. 2. P. 717–727. DOI: [10.22075/IJNAA.2019.19003.2049](https://doi.org/10.22075/IJNAA.2019.19003.2049)
4. Choi J., Datta S. K., Biswas T., Islam Md N. Some fixed point theorems in connection with two weakly compatible mappings in bicomplex valued metric spaces. *Honam Mathematical J.*, 2017. Vol. 39, No. 1. P. 115–126. DOI: [10.5831/HMJ.2017.39.1.115](https://doi.org/10.5831/HMJ.2017.39.1.115)
5. Das N. R., Dey R., Tripathy B. C. Statistically convergent and statistically Cauchy sequence in a cone metric space. *TWMS J. Pure Appl. Math.*, 2014. Vol. 5, No. 1. P. 59–65.
6. Fast H. Sur la convergence statistique. *Colloq. Math.*, 1951. Vol. 2, No. 3–4. P. 241–244. (in French)
7. Fridy J. A. On statistical convergence. *Analysis*, 1985. Vol. 5, No. 4. P. 301–313. DOI: [10.1524/anly.1985.5.4.301](https://doi.org/10.1524/anly.1985.5.4.301)
8. Rath D., Tripathy B. C. Matrix maps on sequence spaces associated with sets of integers. *Indian J. Pure Appl. Math.*, 1996. Vol. 27, No. 2. P. 197–206.
9. Rochon D., Shapiro M. On algebraic properties of bicomplex and hyperbolic numbers. *An. Univ. Oradea Fasc. Mat.*, 2004. Vol. 11. P. 71–110.
10. Sager N., Sağır B. On completeness of some bicomplex sequence spaces. *Palestine J. Math.*, 2020. Vol. 9, No. 2. P. 891–902.
11. Šalát T. On statistically convergent sequences of real numbers. *Math. Slovaca*, 1980. Vol. 30, No. 2. P. 139–150.

12. Schoenberg I. J. The integrability of certain functions and related summability methods. *Amer. Math. Monthly*, 1959. Vol. 66, No. 5. P. 361–375. DOI: [10.2307/2308747](https://doi.org/10.2307/2308747)
13. Segre C. Le rappresentazioni reali delle forme complesse e gli enti iperalgebrici. *Math. Ann.*, 1892. Vol. 40. P. 413–467. DOI: [10.1007/BF01443559](https://doi.org/10.1007/BF01443559) (in Italiano)
14. Singh S. *A Study of Bicomplex Space with a Topological View Point*. Thesis. Punjab: Lovely Professional University, 2018. 120 p.
15. Srivastava R. K., Srivastava N. K. On a class of entire bicomplex sequences. *South East Asian J. Math. Math. Sci.*, 2007. Vol. 5, No. 3. p. 47–68.
16. Tripathy B. C., Nath P. K. Statistical convergence of complex uncertain sequences. *New Math. Nat. Comput.*, 2017. Vol. 13, No. 3. P. 359–374. DOI: [10.1142/S1793005717500090](https://doi.org/10.1142/S1793005717500090)
17. Tripathy B. C. Matrix transformations between some classes of sequences. *J. Math. Anal. Appl.*, 1997. Vol. 206, No. 2. P. 448–450. DOI: [10.1006/jmaa.1997.5236](https://doi.org/10.1006/jmaa.1997.5236)
18. Tripathy B. C., Sen M. On generalized statistically convergent sequences. *Indian J. Pure Appl. Math.*, 2001. Vol. 32, No. 11. P. 1689–1694.
19. Tripathy B. C. On generalized difference paranormed statistically convergent sequences. *Indian J. Pure Appl. Math.*, 2004. Vol. 35, No. 5. P. 655–663.
20. Wagh M. A. On certain spaces of bicomplex sequences. *Inter. J. Phy. Chem. Math. Fundam.*, 2014. Vol. 7, No. 1. P. 1–6.

TERNARY $*$ -BANDS ARE GLOBALLY DETERMINED

Indrani Dutta[†], Sukhendu Kar^{††}

Jadavpur University,
188, Raja S. C. Mallick Road, Kolkata – 700032, India
[†]indrani.jumath@gmail.com ^{††}karsukhendu@yahoo.co.in

Abstract: A non-empty set S together with the ternary operation denoted by juxtaposition is said to be ternary semigroup if it satisfies the associativity property $ab(cde) = a(bcd)e = (abc)de$ for all $a, b, c, d, e \in S$. The global set of a ternary semigroup S is the set of all non empty subsets of S and it is denoted by $P(S)$. If S is a ternary semigroup then $P(S)$ is also a ternary semigroup with a naturally defined ternary multiplication. A natural question arises: “Do all properties of S remain the same in $P(S)$?” The global determinism problem is a part of this question. A class K of ternary semigroups is said to be globally determined if for any two ternary semigroups S_1 and S_2 of K , $P(S_1) \cong P(S_2)$ implies that $S_1 \cong S_2$. So it is interesting to find the class of ternary semigroups which are globally determined. Here we will study the global determinism of ternary $*$ -band.

Keywords: Rectangular ternary band, Involution ternary semigroup, Involution ternary band, Ternary $*$ -band, Ternary projection.

1. Introduction

In our previous paper [7] we have discussed the global determinism of ternary groups and finite left zero ternary semigroups. Here we will discuss some properties of a rectangular ternary band and of a proper rectangular ternary band and also discuss the global determinism problem of ternary $*$ -band.

Let us briefly present the literature on the problem of global determinism. In 1960 B.M. Shane formulated the importance of studying the problem of global determinism. In 1967, T. Tamura and J. Shafer [11] proved that groups are globally determined. In 1984, T. Tamura [10] proved that rectangular groups are globally determined. In 1984, M. Gould and J.A. Iskra [4] also studied some globally determined classes of semigroups. M. Gould, J.A. Iskra, C. Tsinakis [5, 6] also studied the global determinism problem of semigroup theory. In 1984, Y. Kobayashi [9] proved that semilattices are globally determined. At present, the problem of global determinism is a well-known research problem. M. Vinčić [13] established in 2001, that $*$ -bands are globally determined. In 2014, A. Gan, X. Zhao and Y. Shao [1] proved that clifford semigroups are globally determined. In 2015, A. Gan, X. Zhao and M. Ren [3] studied the global determinism of semigroups having regular globals. A. Gan, X. Zhao and Y. Shao [2] also discussed the globals of idempotent semigroups in 2016 and in 2017, B. Yu, X. Zhao, A. Gan [12] proved that idempotent semigroups are globally determined.

So the problem of global determinism is important and relevant in the ternary theory of semigroups. Here we will prove that ternary $*$ -bands are globally determined.

2. Preliminaries

First we provide the basic definitions and results which are used in the rest of the paper.

Definition 1. A ternary semigroup S is said to be left (resp. right) zero ternary semigroup if for $a, b, c \in S$, $abc = a$ (resp. $abc = c$).

Definition 2. A ternary semigroup S is said to be a ternary band if every element of S is idempotent, i.e. $a^3 = a$ for all $a \in S$.

Definition 3. A ternary semigroup S is said to be rectangular ternary band if $aba = a$ for all $a, b \in S$.

Although the definition of rectangular ternary band and rectangular band in binary are similar, but all the rectangular ternary bands are not rectangular bands in binary. The following example illustrates this fact.

Example 1. Let $M_2(\mathbb{R})$ is the set of all 2×2 matrices over \mathbb{R} . This is a ternary semigroup w.r.t. the natural ternary matrix multiplication.

(i) $\left\{ \begin{pmatrix} -1 & 0 \\ 0 & 0 \end{pmatrix}, \begin{pmatrix} -1 & -1 \\ 0 & 0 \end{pmatrix} \right\} \in M_2(\mathbb{R})$. This is a rectangular ternary band w.r.t. natural ternary matrix multiplication.

(ii) $\left\{ \begin{pmatrix} 0 & 0 \\ -1 & -1 \end{pmatrix}, \begin{pmatrix} -1 & -1 \\ 0 & 0 \end{pmatrix} \right\} \in M_2(\mathbb{R})$. This is a rectangular ternary band w.r.t. natural ternary matrix multiplication.

Lemma 1. A ternary semigroup S is rectangular ternary band if and only if $ababa = a$ and $abcde = ace$ for all $a, b, c, d, e \in S$.

P r o o f. Let S be a rectangular ternary band. Then $aba = a$ for all $a, b \in S$. Therefore,

$$ababa = (aba)ba = aba = a \quad \text{for all } a, b \in S.$$

Now

$$\begin{aligned} abcde &= a(b(adc)b)(cde) = (aba)(d(abc)d)e = a(dcd)e = (adc)(d(ace)d)e \\ &= (a(dcd)a)c(ede) = (ada)ce = ace. \end{aligned}$$

Conversely, suppose that $ababa = a$ and $abcde = ace$. Then

$$aba = (ababa)ba = a(bab)aba = aaa = a^3 = a.$$

Therefore, S is the rectangular ternary band. □

Lemma 2. A ternary semigroup S is a rectangular ternary band if and only if it can be expressed as a cartesian product of left zero and right zero ternary semigroups.

P r o o f. Let S be a rectangular ternary band and u be a fixed element of S . Define two sets L, R such that

$$L = \{xuu : x \in S\}, \quad R = \{uux : x \in S\}.$$

Since

$$(xuu)(yuu)(zuu) = x(uuy)u(uzu)u = xuu$$

for all $xuu, yuu, zuu \in L$, we have, L is left zero ternary semigroup. Similarly,

$$(uux)(uuy)(uuz) = u(uxu)u(yuu)z = uuz$$

for all $uux, uuy, uuz \in R$ implies that R is right zero ternary semigroup.

Define a mapping $\phi : S \rightarrow L \times R$ such that $\phi(x) = (xuu, uux)$ for all $x \in S$. Here the ternary operation on $L \times R$ is as follows:

$$(a, b)(c, d)(e, f) = (ace, bdf) = (a, f) \quad \text{for all } (a, b), (c, d), (e, f) \in L \times R.$$

Let $\phi(x) = \phi(y)$. This implies that $xuu = yuu, uux = uuy$. Now

$$x = xux = xuuux = (xuu)ux = (yuu)ux = yu(uux) = yu(uuy) = yuuuy = yuy = y.$$

Therefore, ϕ is one-to-one mapping.

$$\phi(xuz) = (xuzuu, uuxuz) = ((xuu)(uuu)(zuu), (uux)(uuu)(uuz)) = (xuu, uuz).$$

Therefore, ϕ is an onto mapping.

$$\begin{aligned} \phi(x)\phi(y)\phi(z) &= (xuu, uux)(yuu, uuy)(zuu, uuz) \\ &= (xuuuyuuuzuu, uuxuuyuuuz) = (xuu, uuz) = \phi(xyz). \end{aligned}$$

Thus ϕ is a ternary homomorphism. Hence ϕ is an isomorphism and $S \cong L \times R$.

Conversely, suppose that S is isomorphic to $L \times R$, where L, R are left zero, right zero ternary semigroups respectively. Now $(a, c)(e, g)(a, c) = (aea, cgc) = (a, c)$. Therefore, $L \times R$ is a rectangular ternary band. Since S is isomorphic to a rectangular ternary band, S is also rectangular ternary band. \square

Let $S \cong L \times R$ where L be the left zero, R be the right zero ternary semigroup and μ be an isomorphism from S to $L \times R$. The ternary operation on $L \times R$ is defined as

$$(a, b)(c, d)(e, f) = (ace, bdf) = (a, f) \quad \text{for all } (a, b), (c, d), (e, f) \in L \times R.$$

There are some notions defined as follows:

Let $A \in P(S)$, where $P(S)$ is the global of S .

$$\pi_L(A) = \{i \in L : \exists k \in R \text{ such that } (i, k) \in \mu(A)\}.$$

$$\pi_R(A) = \{k \in R : \exists i \in L \text{ such that } (i, k) \in \mu(A)\}.$$

If $S = L \times R$ then for any $A \in P(S)$, we have

$$\pi_L(A) = \{i \in L : \exists k \in R \text{ such that } (i, k) \in (A)\}.$$

$$\pi_R(A) = \{k \in R : \exists i \in L \text{ such that } (i, k) \in (A)\}.$$

Definition 4. A rectangular ternary band S is said to be a proper rectangular ternary band if it is not left zero, right zero and lateral zero ternary semigroup. By the notation TRB_2 we mean the proper rectangular ternary band.

Definition 5. (i) A ternary semigroup S is said to be an involution ternary semigroup if it is equipped with a unary operation $*$ such that $(xyz)^* = z^*y^*x^*$ and $(x^*)^* = x$.

(ii) An idempotent involution ternary semigroup is said to be an involution ternary band.

Definition 6. (i) Let S be an involution ternary semigroup. If for each $x \in S$, $xx^*x = x$, $x^*xx^* = x^*$ and $x^2y = xy^2$ for all $x, y \in S$, then S is said to be a ternary *-semigroup.

(ii) A ternary semigroup S is said to be ternary *-band if S is an idempotent ternary *-semigroup.

Definition 7. Let S be an involution ternary semigroup. An element $x \in S$ is said to be a projection of S if it is idempotent and is a fixed point of involution, i.e. $x^3 = x$ and $x^* = x$.

Definition 8. Let S be an involution ternary semigroup. Then $X \subseteq S$ is said to be an involution ternary subsemigroup if X is a subsemigroup of S and $X^* \subseteq X$, where $X^* = \{x^* : x \in X\}$.

Two important notations of this paper are as follows:

The set of all subsemigroups of a ternary *-band S is denoted by $\mathcal{S}(S)$ and

$$Ch(S) = \{X \in \mathcal{S}(S) : X = Y^3 \implies X = Y \text{ for all } Y \in P(S)\}.$$

Remark 1. Every bijection between two left (resp. right) zero ternary semigroups is the isomorphism between them.

We have already discussed in [7], that finite left (resp. right) zero ternary semigroups are globally determined. In this paper, we generalize this result for arbitrary left (resp. right) zero ternary semigroups.

Here we assume the generalized continuum hypothesis which states that if cardinality of an infinite set lies between that of an infinite set A and that of the power set $P(A)$ of A , then it has the same cardinality as either A or $P(A)$.

Lemma 3. If $P(S_1) \cong P(S_2)$ then $|S_1| = |S_2|$ where $|S_1|$ and $|S_2|$ denote cardinality of S_1, S_2 respectively.

P r o o f. To prove the result we consider the following three cases.

Case 1. Suppose that S_1, S_2 both are finite sets. Let $|S_1| = m$ and $|S_2| = n$.

Since $P(S_1) \cong P(S_2)$, so $|P(S_1)| = |P(S_2)|$. Again $|P(S_1)| = 2^m$ and $|P(S_2)| = 2^n$. Therefore, $2^m = 2^n$. This implies that $m = n$.

Case 2. Suppose that S_1 is a finite set and S_2 is an infinite set and $|S_1| = m$. Then $|P(S_1)| = 2^m$, i.e. a finite number but $|P(S_2)|$ is not a finite number. Therefore, $|P(S_1)| \neq |P(S_2)|$. Hence Case 2 is not true.

Case 3. Let us assume that both S_1, S_2 are infinite sets. Then the following three situations may arise.

(i) If S_1 and S_2 both are countable then $|S_1| = |S_2| = \aleph_0^1$. So there is nothing to prove.

(ii) Suppose S_1 is a countable set and S_2 is an uncountable set. Then $|S_1| = \aleph_0 \implies |P(S_1)| = 2^{\aleph_0}$ and $|S_2| \geq 2^{\aleph_0}$. Therefore, $|P(S_2)| > 2^{\aleph_0} = |P(S_1)|$. But this is not possible.

(iii) Suppose S_1 and S_2 both are uncountable. If possible, let $|S_1| \neq |S_2|$. Then $|S_1| = \mathbf{c}$ and $|S_2| = \mathbf{c}_1$ where $\mathbf{c}, \mathbf{c}_1 \geq 2^{\aleph_0}$. Therefore, $|P(S_1)| = 2^{\mathbf{c}}$ and $|P(S_2)| = 2^{\mathbf{c}_1}$. Since $\mathbf{c} \neq \mathbf{c}_1$ thus $2^{\mathbf{c}} \neq 2^{\mathbf{c}_1}$. This contradicts our assumption. Therefore, $|S_1| = |S_2|$. \square

Theorem 1. Left (resp. right) zero ternary semigroups are globally determined.

P r o o f. Let S_1 and S_2 be two left zero ternary semigroups and $\phi : P(S_1) \longrightarrow P(S_2)$ is an isomorphism, i.e. $P(S_1) \cong P(S_2)$. This implies that $|P(S_1)| = |P(S_2)|$. Hence by Lemma 3, $|S_1| = |S_2|$. Thus there is a bijection from S_1 to S_2 . Since S_1 and S_2 are left zero ternary semigroups, by Remark 1, it follows that the bijection is an isomorphism. So it is clear that $S_1 \cong S_2$. Hence the class of all left zero ternary semigroups is globally determined.

Similarly, we can show that right zero ternary semigroups are globally determined. \square

¹ \aleph is the cardinality of the set of all natural number.

3. Main result

A rectangular ternary band is said to be a proper rectangular ternary band if it is not a left zero, right zero or lateral zero ternary semigroup. In this section, we provide some results of proper rectangular ternary bands and show that the proper rectangular ternary band satisfies the strong isomorphism property. By strong isomorphism property we mean that any isomorphism ϕ from $P(S)$ to $P(S_1)$ is also an isomorphism from S to S_1 . Here we also discuss that ternary $*$ -bands are globally determined. Unless otherwise stated, in this section, we assume that S is a proper rectangular ternary band.

Lemma 4. *Let S and S_1 be two ternary semigroups such that $P(S) \cong P(S_1)$ and ψ is an isomorphism from $P(S)$ to $P(S_1)$. Then the restriction $\psi|_{Ch(S)}$ is a bijection from $Ch(S)$ to $Ch(S_1)$.*

P r o o f. Let $A \in Ch(S)$. This implies that $A \in \mathcal{S}(S)$. Therefore, $\psi(A) \in \mathcal{S}(S_1)$.

Let $\psi(A) = A_1$. If possible, there exists $B_1 \in P(S_1)$ such that $B_1^3 = A_1$. Since ψ is an isomorphism there exists $B \in P(S)$ such that $\psi(B) = B_1$. Therefore, $A_1 = B_1^3 = (\psi(B))^3 = \psi(B^3)$.

Hence $\psi(A) = \psi(B^3)$. This implies that $A = B^3$. Since $A \in Ch(S)$, we have $A = B$. Therefore, $\psi(A) = \psi(B)$. This implies that $A_1 = B_1$. Hence $A_1 \in Ch(S_1)$. Therefore, $\psi|_{Ch(S)}$ is a bijection from $Ch(S)$ to $Ch(S_1)$. \square

Lemma 5. *Let S be a proper rectangular ternary band such that $S = L \times R$. Then $A \in Ch(S)$ if and only if $|\pi_L(A)| = 1$ or $|\pi_R(A)| = 1$.*

P r o o f. The proof is similar to the binary result of [2]. \square

Theorem 2. *Rectangular ternary bands are globally determined.*

P r o o f. Proof of the theorem immediately follows from the binary result of [10]. \square

Theorem 3. *Proper rectangular ternary band satisfies the strong isomorphism property.*

P r o o f. The proof is similar to the binary result of [2]. \square

A restricted class of a involution ternary semigroup is ternary $*$ -band. Unless otherwise stated, in the rest of this section, B denotes an involution ternary band and $\mathcal{S}(B)$ denotes the set of all involution ternary subsemigroups of B .

Lemma 6. *For any involution ternary band B , $\mathcal{S}(B)$ coincides with the set of all projections of $P(B)$. Therefore, if B_1 and B_2 be two involution ternary bands, then every isomorphism $\psi : P(B_1) \rightarrow P(B_2)$ induces a bijection from $\mathcal{S}(B_1)$ to $\mathcal{S}(B_2)$.*

P r o o f. Since B is a involution ternary band, for any subset X of B , we have $X \subset X^3$ and $(X^*)^* = X$.

Now let $X \in \mathcal{S}(B)$. This implies $X^3 \subseteq X$, $X^* \subseteq X$ and $X \subseteq B$. Thus $X^3 = X$ and $(X^*)^* \subseteq X^*$. Hence $X^3 = X$ and $X \subseteq X^*$.

Therefore, $X^3 = X$ and $X^* = X$. So X is a projection of $P(B)$.

Conversely, if X is a projection of $P(B)$ then $X^3 = X$ and $X = X^*$. Therefore, $X^3 \subseteq X$ and $X^* \subseteq X$. Thus $X \in \mathcal{S}(B)$.

Hence $\mathcal{S}(B)$ is the set of all projections of $P(B)$.

Let $\psi : P(B_1) \rightarrow P(B_2)$ be an isomorphism, where B_1, B_2 be two involution ternary bands. We have to show that $X \in \mathcal{S}(B_1)$ implies that $\psi(X) \in \mathcal{S}(B_2)$. Let us extend ψ on $(P(B_1))^*$ as $\psi : (P(B_1))^* \rightarrow (P(B_2))^*$ such that $\psi(X^*) = (\psi(X))^*$.

If $X = X^*$ then $\psi(X) = \psi(X^*) = (\psi(X))^*$. Hence $X \in \mathcal{S}(B_1)$ implies that $\psi(X) \in \mathcal{S}(B_2)$. Thus $\psi(\mathcal{S}(B_1)) \subseteq \mathcal{S}(B_2)$. Similarly, $\psi^{-1}(\mathcal{S}(B_2)) \subseteq \mathcal{S}(B_1)$. This implies that

$$\psi(\psi^{-1}(\mathcal{S}(B_2))) \subseteq \psi(\mathcal{S}(B_1)) \implies \mathcal{S}(B_2) \subseteq \psi(\mathcal{S}(B_1)).$$

Therefore, $\mathcal{S}(B_2) = \psi(\mathcal{S}(B_1))$. Thus ψ induces a bijection between $\mathcal{S}(B_1)$ and $\mathcal{S}(B_2)$. \square

Lemma 7. *Let B_1, B_2 be two involution ternary bands. Any isomorphism from $P(B_1)$ to $P(B_2)$ induces a bijection from $Ch(B_1)$ to $Ch(B_2)$.*

Proof. If we are able to show that for any isomorphism $\psi : P(B_1) \rightarrow P(B_2)$, $\psi(Ch(B_1)) = Ch(B_2)$ then $\psi : Ch(B_1) \rightarrow Ch(B_2)$ becomes onto mapping. Again since ψ is an isomorphism from $P(B_1)$ to $P(B_2)$ and $Ch(B_1) \subseteq P(B_1)$ so $\psi : Ch(B_1) \rightarrow Ch(B_2)$ is one-to-one mapping hence a bijection.

Let $X \in Ch(B_1)$. If possible there exists $Y' \in P(B_2)$ such that $Y'^3 = \psi(X)$. Then there exists $Y \in P(B_1)$ such that $\psi(Y) = Y'$. Therefore,

$$\psi(X) = Y'^3 = (\psi(Y))^3 = \psi(Y^3).$$

This implies that $X = Y^3$ because $X \in Ch(B_1)$. Hence $X = Y$. Thus $\psi(X) = \psi(Y)$. Therefore, $\psi(X) = Y'$. So $X \in Ch(B_1)$ implies that $\psi(X) \in Ch(B_2)$. Hence $\psi(Ch(B_1)) \subseteq Ch(B_2)$.

Since ψ is an isomorphism, ψ^{-1} is also an isomorphism. Hence $Y \in Ch(B_2)$ implies that $\psi^{-1}(Y) \in Ch(B_1)$. Thus

$$\psi^{-1}(Ch(B_2)) \subseteq Ch(B_1) \implies \psi(\psi^{-1}(Ch(B_2))) \subseteq \psi(Ch(B_1)) \implies Ch(B_2) \subseteq \psi(Ch(B_1)).$$

Hence $\psi(Ch(B_1)) = Ch(B_2)$.

Therefore, ψ is a bijection from $Ch(B_1)$ to $Ch(B_2)$. \square

Let us define partial ordering and a chain on a ternary band as follows.

Definition 9. *Let B be a ternary band. A partial order \leq on a ternary band B can be defined as $a \leq b$ if and only if*

$$a = a^2b = ab^2 = b^2a = ba^2.$$

Definition 10. *Let A be a non empty subset of a ternary band B . Then A is said to be a chain of B if for all $a, b \in A$ either $a \leq b$ or $b \leq a$.*

Lemma 8. *Let B be a ternary *-band. Then $X \in Ch(B)$ if and only if X is a chain of projections.*

P r o o f. Let B be a ternary $*$ -band. Then

$$x^3 = x, \quad (x^*)^* = x, \quad x^*xx^* = x^*, \quad xx^*x = x \quad \text{and} \quad x^2y = xy^2 \quad \text{for all } x, y \in B.$$

Suppose $X \in Ch(B)$ and $x, y \in X$. If possible let $x^2y \notin \{x, y\}$. Construct $Y = X \setminus \{x^2y\}$. Now $x^2y \in Y^3$ and $Y \subseteq X$. Since B is ternary $*$ -band and $Y \subseteq X \subseteq B$, we have $Y \subseteq Y^3$. Thus it follows that $Y^3 = X$. Again

$$Y \subseteq X \implies Y^3 \subseteq X^3 = X.$$

Now

$$Y = X \setminus \{x^2y\} \subseteq Y^3 \subseteq X.$$

Since $x^2y \in Y^3$, it follows that $Y^3 \neq Y$. Hence $Y^3 = X$. By definition of $Ch(B)$ we find that $Y = X$. This contradicts our assumption that $x^2y \notin \{x, y\}$. Therefore, $x^2y \in \{x, y\}$. Similarly, $xy^2, yx^2, y^2x, xyx, yxy$ all are in $\{x, y\}$. Hence X is a chain.

Now our aim is to show that $x \in X$ implies that x is a projection. Since $X \in Ch(B)$, $X^3 = X$. Therefore, $x^* \in X$ for all $x \in X$. Now $x^2x^* \in \{x, x^*\}$.

Suppose $x^2x^* = x$. This implies that

$$(x^2x^*)^* = x^* \implies xx^*x^* = x^* \implies x^2x^* = x^*.$$

Therefore, $x = x^*$. Hence x is the projection.

Again if

$$x^2x^* = x^* \implies xx^*x^* = x \implies x^2x^* = x.$$

Hence $x^* = x$. Therefore, x is the projection.

This implies that X is a chain of projections.

Conversely, suppose that $X \in P(B_1)$ is a chain of projections. Suppose there exists $Y \in P(B_1)$ such that $Y^3 = X$. It is clear that $Y \subseteq Y^3$. Therefore, $Y \subseteq X$. Subset of a chain must be a chain. Hence $Y^3 \subseteq Y$. This implies $X \subseteq Y \subseteq X$. Thus $X = Y$. Therefore, $X \in Ch(B)$. \square

Let B be a ternary $*$ -band. Let define a partial ordering “ \leq ” on $P(B)$ as follows:

$X \leq Y$ if and only if $X = X^2Y = YX^2$ for all $X, Y \in P(B)$.

$X \rightarrow Y$ if and only if $X < Y$ in $\mathcal{S}(B)$ and there does not exist any $Z \in \mathcal{S}(B)$ such that $X < Z < Y$.

Again $X \rightarrow Y$ if and only if $X < Y$ and there does not exist any $Z \in Ch(B)$ such that $X < Z < Y$.

It is clear that

$$X \rightarrow Y \implies X \longrightarrow Y.$$

Remark 2. If B is a ternary band then B is also a ternary semigroup. So ideal of a ternary band is the same as the ideal of a ternary semigroup.

Lemma 9. *Let B be a ternary band. Thus there exists some ternary semilattice S such that there is a homomorphism $\sigma : B \longrightarrow S$ such that $\sigma(B) = S$.*

P r o o f. Let B be a ternary band. Define

$$I_a = \{xay : x, y \in B\}$$

for any $a \in B$. Then I_a is an ideal of B , generated by a .

Let us define a relation ρ on B such that $a\rho b$ if and only if $I_a = I_b$. There is no doubt that ρ is an equivalence relation on B . Now let $I_{a_1} = I_{b_1}$, $I_{a_2} = I_{b_2}$, $I_{a_3} = I_{b_3}$. Therefore,

$$b_1 = x_1 a_1 y_1, \quad b_2 = x_2 a_2 y_2, \quad b_3 = x_3 a_3 y_3.$$

Hence

$$\begin{aligned} b_1 b_2 b_3 &= x_1 a_1 y_1 x_2 a_2 y_2 x_3 a_3 y_3 = x_1 (a_1 y_1 x_2 a_2^2) a_2 y_2 x_3 a_3 y_3 \\ &= x_1 (a_1 y_1 x_2 a_2^2) (a_1 y_1 x_2 a_2^2) (a_1 y_1 x_2 a_2^2) a_2 y_2 x_3 a_3 y_3 = x_1 X (a_2 a_1 y_1 x_2 a_2 y_2 x_3) a_3 y_3 \\ &= x_1 X (a_2 a_1 Y a_3^2) a_3 y_3 = x_1 X (a_2 a_1 Y a_3^2) (a_2 a_1 Y a_3^2) (a_2 a_1 Y a_3^2) a_3 y_3 \\ &= (x_1 X a_2 a_1 Y a_3^2 a_2 a_1 Y a_3) (a_3 a_2 a_1) (Y a_3 y_3) = X_1 (a_3 a_2 a_1) Y_1, \end{aligned}$$

where

$$X = a_1 y_1 x_2 a_2^2 a_1 y_1 x_2 a_2, \quad Y = y_1 x_2 a_2 y_2 x_3, \quad X_1 = x_1 X a_2 a_1 Y a_3^2 a_2 a_1 Y a_3, \quad Y_1 = Y a_3 y_3.$$

Therefore, $b_1 b_2 b_3 \in I_{a_3 a_2 a_1}$. Similarly, we can show that $a_3 a_2 a_1 \in I_{b_1 b_2 b_3}$.

Thus it is clear that $I_{a_3 a_2 a_1} = I_{b_1 b_2 b_3}$. Now

$$(i) \quad abc = abcabcabc = a(bca)bcabc \in I_{bca}.$$

Similarly, we can show that $bca \in I_{abc}$. This implies that $I_{abc} = I_{bca}$. Again

$$\begin{aligned} (ii) \quad abc &= abcabcabc = a(bcabc)(bcabc)(bcabc)abc \\ &= (abcab)(cbcabcbca)(bcabc) = (abcab)(bcxa)(bcabc) \\ &= (abcab)(bcxa)(bcxa)(bcxa)(bcabc) = (abcabcxcx)acb(cxacbcxabcabc), \end{aligned}$$

where $x = abcbc$. Therefore, $abc \in I_{acb}$. Hence $I_{abc} = I_{acb}$. Thus

$$I_{abc} = I_{acb} = I_{bac} = I_{bca} = I_{cab} = I_{cba}.$$

This shows that $I_{a_1 a_2 a_3} = I_{b_1 b_2 b_3}$. Therefore, ρ is a ternary congruence relation on B .

Now B/ρ be the set of all equivalence classes of the congruence relation and the elements are denoted by \bar{a} for $a \in B$. Define a ternary operation on B/ρ by $\bar{a}\bar{b}\bar{c} = \overline{abc}$.

Now we show that B/ρ is a ternary semilattice w.r.t. above defined ternary operation. This is clear from the above discussion that B/ρ is a commutative ternary semigroup. Again since B is ternary band,

$$\bar{a}\bar{a}\bar{a} = \overline{aaa} = \bar{a}^3 = \bar{a}.$$

Thus B/ρ is also a ternary band. Now

$$a^2 b = a^2 b^3 = a(ab^2)b \in I_{ab^2}, \quad ab^2 = a^3 b^2 = a(a^2 b)b \in I_{a^2 b}.$$

Therefore, $I_{a^2 b} = I_{ab^2}$. This implies that $\overline{a^2 b} = \overline{ab^2}$. Hence $\bar{a}^2 \bar{b} = \bar{a} \bar{b}^2$. Thus B/ρ is a ternary semilattice.

Now we define a mapping $\sigma : B \rightarrow B/\rho$ such that $\sigma(a) = \bar{a}$. Then σ is an epimorphism. If we consider $S = B/\rho$ then there exists a ternary semilattice which is homomorphic image of B . \square

Lemma 10. *Let B be a ternary *-band and S be a ternary semilattice image of B . If $X, Y \in Ch(B)$ are such that $X < Y$ and $\sigma(X) \rightarrow \sigma(Y)$ [resp. $\sigma(X) \rightarrow \sigma(Y)$] holds in $P(S)$ then $X \rightarrow Y$ [resp. $X \rightarrow Y$], where S is the semilattice image of B and σ is the corresponding epimorphism from B to S .*

P r o o f. Let $\sigma : B \rightarrow S$ be an epimorphism. Then

$$\sigma(X) \rightarrow \sigma(Y) \implies \sigma(X) < \sigma(Y).$$

Suppose $Z \in \mathcal{S}(B)$ be such that $X < Z < Y$. Now $Z \in \mathcal{S}(B)$ implies that $\sigma(Z) \in \mathcal{S}(S)$, since $(\sigma(Z))^3 = \sigma(Z^3) = \sigma(Z)$. Therefore,

$$X = X^2Z = XZ^2 = ZX^2 = Z^2X.$$

This implies that

$$\sigma(X) = \sigma(X)^2\sigma(Z) = \sigma(X)\sigma(Z)^2 = \sigma(Z)\sigma(X)^2 = \sigma(Z)^2\sigma(X).$$

Hence $\sigma(X) < \sigma(Z)$. Thus it follows that $\sigma(X) < \sigma(Z) < \sigma(Y)$. This contradicts $\sigma(X) \rightarrow \sigma(Y)$.

Hence $\sigma(X) \rightarrow \sigma(Y) \implies X \rightarrow Y$.

Again let $X, Y \in Ch(B)$ such that $\sigma(X) \rightarrow \sigma(Y)$. If possible, there exists $Z \in Ch(B)$ such that $X < Z < Y$. This implies $\sigma(X) < \sigma(Z) < \sigma(Y)$. Since $Z \in Ch(B)$ implies that $\sigma(Z) \in Ch(S)$, this contradicts that $\sigma(X) \rightarrow \sigma(Y)$. Hence $X \rightarrow Y$. \square

Lemma 11. *Let B be a ternary $*$ -band and $X \in Ch(B)$. If $x \in X$ is not a maximal element of X then $X \rightarrow X \setminus \{x\}$.*

P r o o f. Let $X \in Ch(B)$. This implies that $X^3 = X$. Now

$$X^2(X \setminus \{x\}) = X(X \setminus \{x\})^2 \subseteq X^3 = X.$$

Let $h \in X$ and $h \neq x$. Then $h = h^3 \in X^2(X \setminus \{x\})$. Again if $h = x$ then there exists some $y \in X$ such that $x = x^2y = xy^2$. Therefore, $h = x = x^2y \in X^2(X \setminus \{x\})$. This implies that $X \subseteq X^2(X \setminus \{x\})$. Hence $X^2(X \setminus \{x\}) = X$. Thus $X < X \setminus \{x\}$. Since $X \in Ch(B)$, $X \setminus \{x\} \in Ch(B)$. Since $\{x\}$ is not a maximal element of X , $\sigma(\{x\})$ is also not a maximal element of $\sigma(X)$. Then from [8], we can write

$$\sigma(X) \rightarrow \sigma(X) \setminus \sigma(\{x\}) = \sigma(X \setminus \{x\}).$$

Hence by Lemma 10, it follows that $X \rightarrow X \setminus \{x\}$. \square

Lemma 12. *Let B be a ternary $*$ -band and $X \in Ch(B)$. If X has a greatest element x_1 and there exists a projection $y \in B$ such that $x_1 \rightarrow y$, then $X \rightarrow X \cup \{y\}$.*

P r o o f. Let B be a ternary $*$ -band. Then $y \in B$ implies that

$$(y^*)^* = y, \quad yy^*y = y, \quad y^*yy^* = y^*.$$

Let $X \in Ch(B)$. This implies that X is a chain of projections. If y be a projection of B such that $x_1 \rightarrow y$ then it is clear that $X \cup \{y\}$ is also a chain of projections. Hence $X \cup \{y\} \in Ch(B)$. Now

$$X^2(X \cup \{y\}) = X^3 \cup X^2\{y\} = X.$$

Similarly, $(X \cup \{y\})X^2 = X$. Again

$$X(X \cup \{y\})^2 = X^3 \cup X^2\{y\} \cup X\{y\}^2 \cup X\{y\}X = X, \quad (X \cup \{y\})^2X = X.$$

Therefore, $X < (X \cup \{y\})$.

If possible, there exists $Y \in Ch(B)$ such that $X < Y < (X \cup \{y\})$. Thus

$$X^2Y = YX^2 = X \quad \text{and} \quad Y^2(X \cup \{y\}) = (X \cup \{y\})Y^2 = Y.$$

Therefore, $Y^2X \cup Y^2\{y\} = Y$. This implies that

$$X \cup Y^2\{y\} = Y \implies X \subseteq Y.$$

If $X \neq Y$ then there exists $z \in Y$ such that $z \notin X$. Again let $z \in Y \setminus X$. If $z < x_1$ then

$$z = zx_1^2 = z^2x_1 = x_1z^2 = x_1^2z \in YX^2 = X.$$

So $z \in X$. This contradicts our assumption that $X \neq Y$.

Hence $x_1 < z$. Since

$$X \cup Y^2\{y\} = X \cup \{y\}Y^2 = Y, \quad z \in Y^2\{y\} = \{y\}Y^2.$$

Therefore, $z = y_1y_2y = yy_3y_4$ for some $y_1, y_2, y_3, y_4 \in Y$.

This implies that

$$zy^2 = y_1y_2yy^2 = y_1y_2y = z, \quad y^2z = y^2(yy_3y_4) = y^3y_3y_4 = yy_3y_4 = z.$$

Hence $z = zy^2 = y^2z$. Therefore, $z < y$.

Thus we get $x_1 < z < y$. This contradicts the relation $x_1 \longrightarrow y$. Hence our assumption is not true and so $X \longrightarrow X \cup \{y\}$. \square

Lemma 13. *Let B be a ternary *-band and let $x \in B$ be a projection. If $\{x\} \longrightarrow Y$ for some $Y \in Ch(B)$ then $Y = \{x, y\}$ with $x \longrightarrow y$.*

P r o o f. Since $\{x\} \longrightarrow Y$, we get $\{x\}^2Y = Y\{x\}^2 = \{x\}$. Hence for any $y \in Y$, $x^2y = yx^2 = x$. This implies that $x \leq y$ for all $y \in Y$.

Let $Y_1 = \{x\} \cup Y$. Now

$$Y^2Y_1 = Y^2\{x\} \cup Y^3 = \{x\} \cup Y = Y_1 = YY_1^2, \quad Y_1Y^2 = \{x\}Y^2 \cup Y^3 = \{x\} \cup Y = Y_1 = Y_1^2Y.$$

This implies that $Y_1 \leq Y$.

Again

$$Y_1\{x\}^2 = \{x\}^3 \cup Y\{x\}^2 = \{x\} = Y_1^2\{x\}, \quad \{x\}^2Y_1 = \{x\}^3 \cup \{x\}^2Y = \{x\} = \{x\}Y_1^2.$$

This implies that $\{x\} < Y_1$. Therefore, $\{x\} < Y_1 \leq Y$. This contradicts the relation $\{x\} \longrightarrow Y$. Hence $Y_1 = Y$. This implies $x \in Y$.

Next we assume that $z \in Y \setminus \{x\}$ is an arbitrary element. Consider the set

$$Z = \{y \in Y : y \leq z\}.$$

Since $Y \in Ch(B)$, Z is also a chain of projections. Now $z \in Z$ implies that Z is nonempty. Hence

$$x^2Z = \{x^2y : y \leq z\} = \{x\}.$$

Similarly, $xZ^2 = \{x\}$. Therefore, $\{x\} \leq Z$.

Again let $u \in Z^2Y = ZY^2$. Therefore, $u = z_1z_2y_1$ for some $y_1 \in Y$ and $z_1, z_2 \in Z$. This implies either $y_1 \leq z$ or $y_1 > z$.

Case 1. Let $y_1 \leq z$ then $y_1 z^2 = y_1^2 z = z^2 y_1 = z y_1^2 = y_1$. Hence

$$z^2 u = z^2 z_1 z_2 y_1 = z_1 z_2 y_1 = u, \quad u z^2 = z_1 z_2 y_1 z^2 = z_1 z_2 y_1 = u.$$

This implies $u \leq z$.

Case 2. Let $y_1 > z$ then $y_1 z^2 = y_1^2 z = z^2 y_1 = z y_1^2 = z$. Hence

$$z^2 u = z^2 z_1 z_2 y_1 = z_1 z_2 y_1 = u, \quad u z^2 = z_1 z_2 y_1 z^2 = z_1 z_2 z^2 y_1 = z_1 z_2 y_1 = u.$$

Therefore, $u \leq z$. Thus $u \in Z$. Hence $Z^2 Y = Z Y^2 \subseteq Z$.

Similarly, $v \in Y Z^2 = Y^2 Z \implies v = y_1 z_1 z_2 = y_2 y_3 z_3$. Then either $y_1 \leq z$ or $y_1 > z$.

Case 1. Let $y_1 \leq z$. Then

$$y_1 = y_1 z^2 = y_1^2 z = z^2 y_1 = z y_1^2, \\ z^2 v = z^2 y_1 z_1 z_2 = y_1 z_1 z_2 = v = z v^2, \quad v z^2 = y_1 z_1 z_2 z^2 = y_1 z_1 z_2 = v = v^2 z.$$

Hence $v \leq z$.

Case 2. Let $y_1 > z$. Therefore,

$$z = y_1 z^2 = y_1^2 z = z^2 y_1 = z y_1^2, \\ v z^2 = y_1 z_1 z_2 z^2 = y_1 z_1 z_2 = v, \quad z^2 v = z^2 y_1 z_1 z_2 = y_1 z^2 z_1 z_2 = y_1 z_1 z_2 = v.$$

Hence $v \leq z$. This implies that $v \in Z$. Thus $Y Z^2 = Y^2 Z \subseteq Z$.

Conversely, $Z = Z^3 \subseteq Y^2 Z = Y Z^2$ and $Z = Z^3 \subseteq Z^2 Y = Z Y^2$.

Hence

$$Z = Y^2 Z = Y Z^2 = Z Y^2 = Z^2 Y.$$

This implies that $Z \leq Y$. Therefore, $\{x\} \leq Z \leq Y$. This contradicts the relation $\{x\} \longrightarrow Y$. Hence $Y = Z$. Since z is an arbitrary element, Y has only two elements say $\{x, y\}$. It is clear that $x < y$. If possible $x \twoheadrightarrow y$. Then there exists $z \in Ch(B)$ such that $x < z < y$. Then

$$x^2 \{x, z\} = x \{x, z\}^2 = \{x, z\}^2 x = \{x, y\} x^2 = \{x\}, \\ \{x, z\} Y^2 = x Y^2 \cup z Y^2 = \{x\} \cup \{z\} = \{x, z\} = \{x, z\}^2 Y = Y^2 \{x, z\} = Y \{x, z\}^2.$$

Therefore, $\{x\} < \{x, z\} < Y$. This is a contradiction. Hence $Y = \{x, y\}$ and $x \longrightarrow y$. \square

Proposition 1. *Let B be a ternary $*$ -band and $X \in Ch(B)$ such that $|X| \geq 3$. Then X has a topknot.*

P r o o f. Let $X \in Ch(B)$ and $|X| \geq 3$. Then there exist $x, y, z \in X$ such that $x < y < z$. Since $\{x\}$ and $\{y\}$ are not maximal elements of X , $X \twoheadrightarrow X \setminus \{x\}$ and $X \twoheadrightarrow X \setminus \{y\}$, by Lemma 11. Again $X \setminus \{x\} \twoheadrightarrow X \setminus \{x, y\}$ and $X \setminus \{y\} \twoheadrightarrow X \setminus \{x, y\}$. Therefore, we have the following topknot:

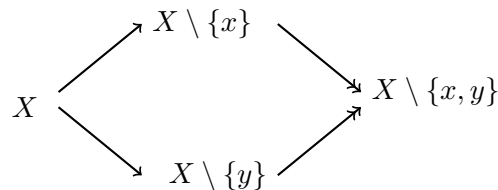

□

Proposition 2. *Let B be a ternary $*$ -band. If $X \in Ch(B)$ and $|X| = 2$ then X has either a maximal hair of length 1 or a topknot.*

Proof. Let $X = \{x, y\}$, with $x < y$. By Lemma 11, it follows that $X \rightarrow X \setminus \{x\} = \{y\}$. If X has no maximal hair of length 1 then there is an element $z \in Ch(B)$ such that $y \rightarrow z$. Again by Lemma 13, $\{y\} \rightarrow \{y, z\}$. Also by Lemma 12, $X \rightarrow X \cup \{z\} = \{x, y, z\}$. Then by Lemma 11, $\{x, y, z\} \rightarrow \{y, z\}$. Hence we can construct the following topknot:

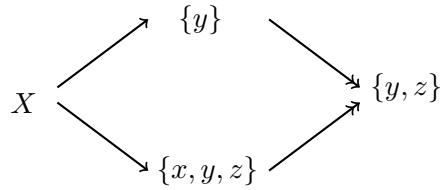

□

Proposition 3. *Let B is a ternary $*$ -band and $X \in Ch(B)$. Then $|X| = 1$ if and only if X has neither maximal hair of length 1 nor topknots.*

Proof. Suppose that $X = \{x\}$ and if possible, X has a maximal hair of length 1. Then there exists $Y \in Ch(B)$ such that $X \rightarrow Y$. Thus by Lemma 13, we get $Y = \{x, y\}$ for some y with $x \rightarrow y$. Since x is not maximal in Y , by Lemma 11, it is clear that $\{x\} \rightarrow Y \rightarrow Y \setminus \{x\}$. This contradicts our assumption that X has a maximal hair of length 1. Now suppose that X has a topknot as follows:

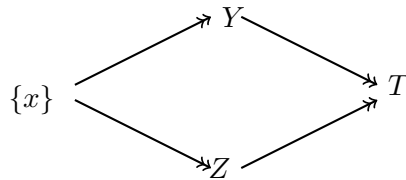

Again by Lemma 13, we have $Y = \{x, y\}$ with $x \rightarrow y$ and $Z = \{x, z\}$ with $x \rightarrow z$ and $y \neq z$ so that $y^2z = yz^2 = zy^2 = z^2y$.

Now $T \in Ch(B)$. Consider $W = \{x, y, z\}$. Since $y^2z = yz^2 = zy^2 = z^2y = x$, $W \notin Ch(B)$.

So $xyz = x$ implies that $W^3 = W$. Hence $W \in \mathcal{S}(S)$. Now

$$\{x, y\}^2W = \{x^3, x^2y, x^2z, xyx, xy^2, xyz, yx^2, yxy, yxz, y^2x, y^3, y^2z\} = \{x, y\}.$$

Similarly,

$$\{x, y\}W^2 = W\{x, y\}^2 = W^2\{x, y\} = \{x, y\}.$$

This shows that $\{x, y\} < W$. Again $W^2T = WT^2 = W$. Thus $\{x, y\} < W < T$. This contradicts the existence of topknot. Hence X has no topknot.

Conversely, suppose that X has neither maximal hair of length 1 nor topknot. If possible, $|X| > 1$. Then Proposition 1 and Proposition 2 contradicts our assumption. Thus the result holds. □

Theorem 4. *Ternary $*$ -band is globally determined.*

P r o o f. Let B_1, B_2 be two ternary $*$ -bands such that $\psi : P(B_1) \rightarrow P(B_2)$ be an isomorphism. Let \bar{B}_1, \bar{B}_2 be the set of all singleton subsets of B_1 and B_2 respectively. Let us define $\psi_1 : B_1 \rightarrow \bar{B}_1$ such that $\psi_1(x) = \{x\}$ and $\psi_2 : \bar{B}_2 \rightarrow B_2$ such that $\psi_2(\{y\}) = y$. Now from the construction of ψ_1, ψ_2 it follows that ψ_1 and ψ_2 be two isomorphisms from B_1 to \bar{B}_1 and from \bar{B}_2 to B_2 respectively.

If we are able to show that $\psi|_{\bar{B}_1}$ is a bijection from \bar{B}_1 to \bar{B}_2 then it follows that $\psi|_{\bar{B}_1} : \bar{B}_1 \rightarrow \bar{B}_2$ is an isomorphism.

Let $X \in Ch(B_1)$ such that $|X| = 1$. Then $X \in \bar{B}_1$. If possible, $\psi(X) = X' \notin \bar{B}_2$, i.e., $|X'| \geq 2$. Then by Proposition 1 and Proposition 2, it follows that X' has either a maximal hair of length 1 or a topknot.

Case 1. Suppose X' has a maximal hair of length 1. Then X has also a maximal hair of length 1. This contradicts that $X \in \bar{B}_1$.

Case 2. Suppose X' has a topknot as follows:

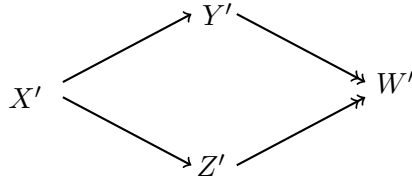

where $Y', Z', W' \in Ch(B_2)$ and $Y' \neq Z'$. Then there exists $Y, Z, W \in Ch(B_1)$ and $Y \neq Z$ such that $Y' = \psi(Y)$, $Z' = \psi(Z)$ and $W' = \psi(W)$. Then the above topknot can be written as follows:

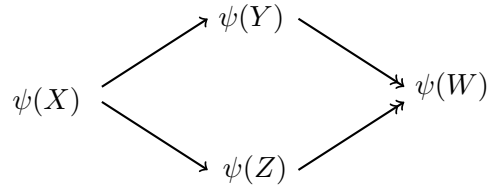

Hence we have the following topknot:

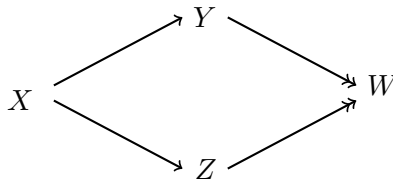

From the Proposition 3, it follows that $X \notin \bar{B}_1$. This contradicts our assumption. Therefore, $|\psi(X)| = |X'| = 1$ and $X' \in Ch(B_2)$. Thus ψ is a bijection from the singleton subset of projection of B_1 to the singleton subset of projection of B_2 .

Now let $x \in B_1$ such that x is not projection. Then $(x^2x^*)^* = xx^{*2} = x^2x^*$. Therefore, x^2x^* is a projection.

Similarly, x^*x^2 is also a projection and $(x^2x^*)(x^2x^*)(x^*x^2) = x$. Therefore, any element of B can be written as a product of three projections, say $x = lmn$, where l, m, n are projections. So

$$\psi(\{x\}) = \psi(\{lmn\}) = \psi(\{l\}\{m\}\{n\}) = \psi(\{l\})\psi(\{m\})\psi(\{n\}) = l_1m_1n_1 = x_1.$$

Therefore, $\{x\} \in \bar{B}_1$ implies that $\psi(\{x\}) \in \bar{B}_2$, i.e., $\psi(\bar{B}_1) \subseteq \bar{B}_2$. Similarly, $\psi^{-1}(\bar{B}_2) \subseteq \bar{B}_1$. This implies that $\psi(\psi^{-1}(\bar{B}_2)) \subseteq \psi(\bar{B}_1)$ and $\bar{B}_2 \subseteq \psi(B_1)$. Hence $\psi(\bar{B}_1) = \bar{B}_2$. Therefore, ψ is an onto

mapping from \bar{B}_1 to \bar{B}_2 and since ψ is an isomorphism from $P(B_1)$ to $P(B_2)$ and $\bar{B}_1 \subseteq P(B_1)$, it follows that $\psi|_{\bar{B}_1}: \bar{B}_1 \rightarrow \bar{B}_2$ is an isomorphism.

Therefore, $\psi_2\psi|_{\bar{B}_1} \psi_1: B_1 \rightarrow B_2$ is an isomorphism. Hence $B_1 \cong B_2$. Thus we conclude that ternary *-bands are globally determined. \square

4. Conclusion

Throughout this paper we investigated the on global determinism of ternary *-bands and successfully proved that ternary *-bands are globally determined. This research enriches the study of global determinism problem on different classes of ternary semigroup. In future we will be able to study the global determinism problem of another class of ternary semigroup with the help of those results that we have proved in this paper. We hope this work will flourish the field of ternary semigroup, specially the global determinism problem on various classes of ternary semigroups.

REFERENCES

1. Gan A., Zhao X. Global determinism of Clifford semigroups. *J. Aust. Math. Soc.*, 2014. Vol. 97, No. 1. P. 63–77. DOI: [10.1017/S1446788714000032](https://doi.org/10.1017/S1446788714000032)
2. Gan A., Zhao X., Shao Y. Globals of idempotent semigroups. *Commun. Algebra*, 2016. Vol. 44, No. 9. P. 3743–3766. DOI: [10.1080/00927872.2015.1087006](https://doi.org/10.1080/00927872.2015.1087006)
3. Gan A., Zhao X., Ren M. Global determinism of semigroups having regular globals. *Period. Math. Hung.*, 2016. Vol. 72. P. 12–22. DOI: [10.1007/s10998-015-0107-y](https://doi.org/10.1007/s10998-015-0107-y)
4. Gould M., Iskra J. A. Globally determined classes of semigroups. *Semigroup Forum*, 1984. Vol. 28. P. 1–11. DOI: [10.1007/BF02572469](https://doi.org/10.1007/BF02572469)
5. Gould M., Iskra J. A., Tsinakis C. Globals of completely regular periodic semigroups. *Semigroup Forum*, 1984. Vol. 29. P. 365–374.
6. Gould M., Iskra J. A., Tsinakis C. Globally determined lattices and semilattices. *Algebra Universalis*, 1984. Vol. 19. P. 137–141. DOI: [10.1007/BF01190424](https://doi.org/10.1007/BF01190424)
7. Kar S., Dutta I. Globally determined ternary semigroups. *Asian-Eur. J. Math.*, 2017. Vol. 10, No. 3. Art. no. 1750038. 13 p. DOI: [10.1142/S1793557117500383](https://doi.org/10.1142/S1793557117500383)
8. Kar S., Dutta I. Global determinism of ternary semilattices. *Asian-Eur. J. Math.*, 2020. Vol. 13, No. 4. Art. no. 2050083. 9 p. DOI: [10.1142/S1793557120500837](https://doi.org/10.1142/S1793557120500837)
9. Kobayashi Y. Semilattices are globally determined. *Semigroup Forum*, 1984. Vol. 29. P. 217–222. DOI: [10.1007/BF02573326](https://doi.org/10.1007/BF02573326)
10. Tamura T. Power semigroups of rectangular groups. *Math. Japon.*, 1984. Vol. 29. P. 671–678.
11. Tamura T., Shafer J. Power semigroups. *Math. Japon.*, 1967. Vol. 12. P. 25–32.
12. Yu B., Zhao X., Gan A. Global determinism of idempotent semigroups. *Communm Algebra*, 2018. Vol. 46. P. 241–253. DOI: [10.1080/00927872.2017.1319474](https://doi.org/10.1080/00927872.2017.1319474)
13. Vinčić M. Global determinism of *-bands. In: *IMC Filomat 2001, Niš, August 26–30, 2001*. 2001. P. 91–97.

WEIGHTED S^p -PSEUDO S -ASYMPTOTICALLY PERIODIC SOLUTIONS FOR SOME SYSTEMS OF NONLINEAR DELAY INTEGRAL EQUATIONS WITH SUPERLINEAR PERTURBATION

Hamza El Bazi[†], Abdellatif Sadrati^{††}

MSISI Laboratory, AM2CSI Group,
Department of Mathematics, FST, Errachidia,
University Moulay Ismal of Meknes, B.P,
509, Boutalamine, 52000, Errachidia, Morocco

[†]hamza.elbazi.uae@gmail.com ^{††}abdo2sadrati@gmail.com

Abstract: This work is concerned with the existence of positive weighted pseudo S -asymptotically periodic solution in Stepanov-like sense for some systems of nonlinear delay integral equations. In this context, we will first be interested in establishing a suitable composition theorem, and then some existing results concerning the S -asymptotic periodicity in the scalar case are developed here for the vector case. We point out that, in this paper, we adopt some changes in the definitions, which, although slight, are necessary to accomplish the work.

Keywords: Weighted S^p -pseudo S -asymptotic periodicity, S -asymptotic periodicity, Systems of nonlinear delay integral equations, Equations with superlinear perturbation.

1. Introduction

The concept of S -asymptotically periodic functions was introduced in the literature by Henríquez et al. [10] in 2008. The concept turns out to generalize that of asymptotically periodic functions. For additional details on this topic, we refer the reader to [1, 5, 7, 8, 10, 11, 18] and the references therein. Since then, S -asymptotically periodic functions are widely investigated and used in the study of differential and integral equations.

However, the notion of weighted S^p -pseudo S -asymptotic periodicity, which was introduced by Xia [17] in 2015, is more general than that of asymptotic periodicity and all its various extensions, namely S -asymptotic periodicity, pseudo S -asymptotic periodicity and weighted pseudo S -asymptotic periodicity.

Motivated by the works on various kinds of systems of nonlinear delay integral equations (see, e.g., [13–16]), on S -asymptotically periodic functions and by the works [9, 17] on weighted Stepanov-like pseudo S -asymptotically periodic functions, we investigate the existence of positive weighted S^p -pseudo S -asymptotically ω -periodic solution ($\omega > 0$) for systems of nonlinear delay integral equations with superlinear perturbations of the following type:

$$\begin{aligned} x(s) &= \alpha_1(s)x^\eta(s-l) + \int_0^{\tau_1(s)} f(s, \sigma, x(s-\sigma-l), y(s-\sigma-l))d\sigma, \\ y(s) &= \alpha_2(s)y^\nu(s-l) + \int_0^{\tau_2(s)} g(s, \sigma, x(s-\sigma-l), y(s-\sigma-l))d\sigma. \end{aligned} \tag{1.1}$$

Let $\eta, \nu \geq 1$ and $l \geq 0$ be fixed numbers, and let $f, g : \mathbb{R} \times \mathbb{R}^+ \times \mathbb{R}^+ \times \mathbb{R}^+ \rightarrow \mathbb{R}^+$, $\alpha_1, \alpha_2 : \mathbb{R} \rightarrow \mathbb{R}^+$, and $\tau_1, \tau_2 : \mathbb{R} \rightarrow \mathbb{R}^+$ be suitable functions satisfying some appropriate conditions mentioned later in the assumptions.

First of all, it is interesting to highlight the biological context of our model. Note that, considering the equation

$$x(s) = \alpha(s)x^\eta(s-l) + \int_0^{\tau(s)} f(s, \sigma, x(s-\sigma-l))d\sigma,$$

we have the scalar case of system (1.1), which generalizes the model studied in 2016 by Zhao et al. [18], if one changes the variable $s - \sigma = u$ and takes $l = 0$:

$$x(s) = \alpha(s)x^\eta(s-l) + \int_{s-\tau(s)}^s f(\sigma, x(\sigma))d\sigma,$$

which in turn generalizes the model

$$x(s) = \int_{s-\tau}^s f(\sigma, x(\sigma))d\sigma$$

published in 1976 by Cooke and Kaplan [4] to explain the spread of some infectious diseases or the population growth of single species.

The work consists of four sections and a conclusion. In the next section, we introduce some basic concepts, definitions, and notation required in what follows. Section 3 is devoted to proving several lemmas and a composition theorem needed to prove our existence result. In Section 4, we give sufficient conditions that ensure the existence and uniqueness of a weighted S^p -pseudo S -asymptotically ω -periodic solution to system (1.1).

2. Some definitions and preliminaries

Throughout the paper, we use the following notation. Let \mathbb{N} be the set of all positive integers, $\mathbb{R} = (-\infty, +\infty)$, $\mathbb{R}^* = (-\infty, 0) \cup (0, +\infty)$, $\mathbb{R}_+ = [0, +\infty)$, $\mathbb{R}_+^n = \mathbb{R}_+ \times \cdots \times \mathbb{R}_+$ (n times), and let, for $x = (x_1, \dots, x_n) \in \mathbb{R}^n$,

$$\|x\| = \sum_{i=1}^n |x_i|.$$

Let $BC(\mathbb{R}, \mathbb{R}^n)$ (resp. $BC(\mathbb{R} \times \mathbb{R}_+ \times \mathbb{R}_+^n, \mathbb{R}^n)$) be the space of continuous bounded functions $f : \mathbb{R} \rightarrow \mathbb{R}^n$ (resp. $f : \mathbb{R} \times \mathbb{R}_+ \times \mathbb{R}_+^n \rightarrow \mathbb{R}^n$). Then, endowed with the sup norm

$$\|f\|_\infty = \sup_{t \in \mathbb{R}} \|f(t)\|,$$

$BC(\mathbb{R}, \mathbb{R}^n)$ is a Banach space. For $1 \leq p \leq +\infty$, $L^p(\mathbb{R}, \mathbb{R}^n)$ denotes the Lebesgue space and $L_{Loc}^p(\mathbb{R}, \mathbb{R}^n)$ denotes the space of all equivalence classes of measurable functions $f : \mathbb{R} \rightarrow \mathbb{R}^n$ such that the restriction of f to every bounded subinterval of \mathbb{R} is in $L^p(\mathbb{R}, \mathbb{R}^n)$. Let $L_{Loc}^{p,1}(\mathbb{R} \times \mathbb{R}_+, \mathbb{R}^n)$ denote the space of all equivalence classes of measurable functions $f : \mathbb{R} \times \mathbb{R}_+ \rightarrow \mathbb{R}^n$, $(s, \sigma) \rightarrow f(s, \sigma)$ such that the restriction of f to every bounded subset of $\mathbb{R} \times \mathbb{R}_+$ is in $L^{p,1}(\mathbb{R} \times \mathbb{R}_+, \mathbb{R}^n) = L^p(\mathbb{R}, L^1(\mathbb{R}_+, \mathbb{R}^n))$.

Furthermore, in the general case when $x = (x_1, \dots, x_n) : \mathbb{R} \rightarrow \mathbb{R}_+^n$, $\tau = (\tau_1, \dots, \tau_n) : \mathbb{R} \rightarrow \mathbb{R}_+^n$, and $f = (f_1, \dots, f_n) : \mathbb{R} \times \mathbb{R}_+ \times \mathbb{R}_+^n \rightarrow \mathbb{R}_+^n$ are appropriate functions, we use the notation

$$\int_0^{\tau(s)} f(s, \sigma, x(s-\sigma-l))d\sigma$$

for the vector of \mathbb{R}^n whose components are

$$\int_0^{\tau_i(s)} f_i(s, \sigma, x_1(s-\sigma-l), \dots, x_n(s-\sigma-l))d\sigma, \quad i = 1, 2, \dots, n.$$

Definition 1 [18]. A function $f \in BC(\mathbb{R}, \mathbb{R}^n)$ is said to be S -asymptotically ω -periodic if there exists $\omega > 0$ such that $\lim_{t \rightarrow \infty} \|f(t + \omega) - f(t)\| = 0$. In this case, we say that ω is an asymptotic period of f . We denote by $SAP_\omega(\mathbb{R}, \mathbb{R}^n)$ the set of all such functions.

Lemma 1 [18]. Let $f, g \in SAP_\omega(\mathbb{R}, \mathbb{R}^n)$. Then the following assertions hold:

- (i) the function $t \rightarrow f(t + s)$ lies in $SAP_\omega(\mathbb{R}, \mathbb{R}^n)$ for every $s \in \mathbb{R}$;
- (ii) the product $f \cdot g$ lies in $SAP_\omega(\mathbb{R}, \mathbb{R}^n)$;
- (iii) equipped with the sup norm

$$\|f\|_\infty = \sup_{s \in \mathbb{R}} \|f(s)\|,$$

$SAP_\omega(\mathbb{R}, \mathbb{R}^n)$ turns out to be a Banach space.

Let U denote the collection of all functions (weights) $\rho : \mathbb{R}^* \rightarrow (0, +\infty)$ locally integrable over $(-\infty, 0)$ and $(0, +\infty)$ such that $\rho(t) > 0$ for almost all $t \in \mathbb{R}^*$. For $\rho \in U$ and $r > 0$, we set

$$m^-(r, \rho) = \int_{-r}^0 \rho(s) ds \quad \text{and} \quad m^+(r, \rho) = \int_0^r \rho(s) ds.$$

Throughout this paper, the set of weights U_∞ stands for

$$U_\infty = \left\{ \rho \in U : \lim_{r \rightarrow +\infty} m^-(r, \rho) = +\infty \text{ and } \lim_{r \rightarrow +\infty} m^+(r, \rho) = +\infty \right\}.$$

Obviously, $U_\infty \subset U$, with strict inclusions.

Definition 2. Let $\rho \in U_\infty$ and $f \in BC(\mathbb{R}, \mathbb{R}^n)$. If

$$\begin{aligned} \lim_{r \rightarrow +\infty} \frac{1}{m^-(r, \rho)} \int_{-r}^0 \|f(s - \omega) - f(s)\| \rho(s) ds &= 0, \\ \lim_{r \rightarrow +\infty} \frac{1}{m^+(r, \rho)} \int_0^r \|f(s + \omega) - f(s)\| \rho(s) ds &= 0, \end{aligned}$$

for some $\omega > 0$, then we call f weighted pseudo S -asymptotically ω -periodic. The collection of such functions is denoted by $PSAP_\omega(\mathbb{R}, \mathbb{R}^n, \rho)$. In particular, we use the notation $PSAP_\omega(\mathbb{R}, \mathbb{R}^n)$ when $\rho \equiv 1$. Equipped with the sup norm

$$\|f\|_\infty = \sup_{s \in \mathbb{R}} \|f(s)\|,$$

$PSAP_\omega(\mathbb{R}, \mathbb{R}^n, \rho)$ turns out to be a Banach space.

Definition 3 [6]. The Bochner transform $f^b(t, s)$, $t \in \mathbb{R}$, $s \in [0, 1]$, of a function $f : \mathbb{R} \rightarrow \mathbb{R}^n$, is defined as

$$f^b(t, s) := f(t + s).$$

Remark 1. Note that a function $\varphi(t, s)$, $t \in \mathbb{R}$, $s \in [0, 1]$, is the Bochner transform of a certain function $f(t)$,

$$\varphi(t, s) = f^b(t, s),$$

if and only if $\varphi(t + \tau, s - \tau) = \varphi(s, t)$ for all $t \in \mathbb{R}$, $s \in [0, 1]$, and $\tau \in [s - 1, s]$.

Definition 4 [6]. The Bochner transform $f^b(t, s, \sigma, u)$, $t \in \mathbb{R}$, $s \in [0, 1]$, $(\sigma, u) \in \mathbb{R} \times \mathbb{R}^n$, of a function $f : \mathbb{R} \times \mathbb{R} \times \mathbb{R}^n \rightarrow \mathbb{R}^n$, is defined as

$$f^b(t, s, \sigma, u) := f(t + s, \sigma, u).$$

Definition 5 [12]. Let $p \in [1, +\infty)$.

- (i) The space $BS^p(\mathbb{R}, \mathbb{R}^n)$ of all Stepanov bounded functions, with the exponent p , consists of all measurable functions f on \mathbb{R} with values in \mathbb{R}^n such that $f^b \in L^\infty(\mathbb{R}, L^p([0, 1], \mathbb{R}^n))$. This is a Banach space with the norm

$$\|f\|_{S^p} = \|f^b\|_{L^\infty(\mathbb{R}, L^p)} = \sup_{t \in \mathbb{R}} \left(\int_t^{t+1} \|f(s)\|^p ds \right)^{1/p}.$$

- (ii) The space $BS^p(\mathbb{R} \times \mathbb{R}_+ \times \mathbb{R}_+^n, \mathbb{R}^n)$ of all Stepanov bounded functions, with the exponent p , consists of all measurable functions $f : \mathbb{R} \times \mathbb{R}_+ \times \mathbb{R}_+^n \rightarrow \mathbb{R}^n$ such that

$$f^b(\cdot, \cdot, \sigma, u) \in L^\infty(\mathbb{R}, L^p([0, 1], \mathbb{R}^n)), \quad t \rightarrow f^b(t, \cdot, \sigma, u) \in L^p([0, 1], \mathbb{R}^n),$$

for every $t \in \mathbb{R}$ and every $(\sigma, u) \in \mathbb{R}_+ \times \mathbb{R}_+^n$.

One can see that, for every $f \in L^p_{Loc}(\mathbb{R}, \mathbb{R}^n)$, the function f^b is continuous (by construction). Then, the space $BS^p(\mathbb{R}, \mathbb{R}^n)$ may also be written as

$$BS^p(\mathbb{R}, \mathbb{R}^n) = \{f \in L^p_{Loc}(\mathbb{R}, \mathbb{R}^n) : f^b \in BC(\mathbb{R}, L^p([0, 1], \mathbb{R}^n))\}.$$

In fact, for $p \geq 1$, we have

$$(BC(\mathbb{R}, \mathbb{R}^n), \|\cdot\|_{BC}) \text{ is continuously embedded in } (BS^p(\mathbb{R}, \mathbb{R}^n), \|\cdot\|_{S^p}).$$

Also, it is well known that $L^p(\mathbb{R}, \mathbb{R}^n) \subset BS^p(\mathbb{R}, \mathbb{R}^n) \subset L^p_{Loc}(\mathbb{R}, \mathbb{R}^n)$ and $BS^p(\mathbb{R}, \mathbb{R}^n) \subset BS^q(\mathbb{R}, \mathbb{R}^n)$ for $p \geq q \geq 1$.

Definition 6. Let $\rho \in U_\infty$ and $f \in BS^p(\mathbb{R}, \mathbb{R}^n)$. If

$$\begin{aligned} \lim_{r \rightarrow +\infty} \frac{1}{m^-(r, \rho)} \int_{-r}^0 \rho(t) \left(\int_{t-1}^t \|f(s - \omega) - f(s)\|^p ds \right)^{1/p} dt &= 0, \\ \lim_{r \rightarrow +\infty} \frac{1}{m^+(r, \rho)} \int_0^r \rho(t) \left(\int_t^{t+1} \|f(s + \omega) - f(s)\|^p ds \right)^{1/p} dt &= 0 \end{aligned}$$

for some $\omega > 0$, then we call f weighted S^p -pseudo S -asymptotically ω -periodic. Such function space is denoted by $PSAP_\omega^p(\mathbb{R}, \mathbb{R}^n, \rho)$. In particular, we use the notation $PSAP_\omega^p(\mathbb{R}, \mathbb{R}^n)$ when $\rho \equiv 1$.

Remark 2. The above definition has a slight difference from [17, Definition 3.1], where a weighted S^p -pseudo S -asymptotically ω -periodic function is defined on \mathbb{R}_+ .

Similarly to [9], we give an example illustrating that $PSAP_\omega^p(\mathbb{R}, \mathbb{R}^n) \neq PSAP_\omega^p(\mathbb{R}, \mathbb{R}^n, \rho)$.

Example 1. Define a function $f : \mathbb{R} \rightarrow \mathbb{R}$ as follows:

$$f(t) = \begin{cases} -n^5(t - n^3 - 1/n)^2 + n^3, & t \in [n^3, n^3 + 2/n], \quad n \in \mathbb{N}, \\ -n^5(t + n^3 + 1/n)^2 + n^3, & t \in [-n^3 - 2/n, -n^3], \quad n \in \mathbb{N}, \\ 0, & \text{otherwise.} \end{cases}$$

Then, for all $\omega > 0$, there exists integer n_0 such that $f(s + \omega) = 0$ (resp. $f(s - \omega) = 0$) for all $n \geq n_0$ and $s \in [n^3, n^3 + 2/n]$ (resp. for all $n \geq n_0$ and $s \in [-n^3 - 2/n, -n^3]$). Let $p = 1$, let $r > 0$ be a sufficiently large number, and let k be the largest integer satisfying the inequality

$$n_0^3 + \frac{2}{n_0} \leq k^3 + \frac{2}{k} \leq r.$$

If the function (weight) $\rho \equiv 1$, then, by the same calculation as in [9, Example 2.2], we obtain

$$\begin{aligned} \frac{1}{r} \int_{-r}^0 \left(\int_{t-1}^t \|f(s - \omega) - f(s)\| ds \right) dt &= \frac{1}{r} \int_{-r}^0 \left(\int_{-1}^0 \|f(t + s - \omega) - f(t + s)\| ds \right) dt \\ &= \int_{-1}^0 \left(\frac{1}{r} \int_{-r}^0 \|f(t + s - \omega) - f(t + s)\| dt \right) ds \\ &\geq \int_{-1}^0 \frac{1}{(k+1)^3 + 2/(k+1)} \left(\sum_{n=n_0}^k \int_{-n^3-2/n}^{-n^3} \left[-n^5 \left(t + n^3 + \frac{1}{n} \right)^2 + n^3 \right] dt \right) ds \\ &= \frac{1}{(k+1)^3 + 2/(k+1)} \sum_{n=n_0}^k \frac{4n^2}{3} \rightarrow \frac{4}{9} \quad (k \rightarrow +\infty) \end{aligned}$$

and

$$\begin{aligned} \frac{1}{r} \int_0^r \left(\int_t^{t+1} \|f(s + \omega) - f(s)\| ds \right) dt \\ \geq \int_0^1 \frac{1}{(k+1)^3 + 2/(k+1)} \left(\sum_{n=n_0}^k \int_{n^3}^{n^3+2/n} \left[-n^5 \left(t - n^3 - \frac{1}{n} \right)^2 + n^3 \right] dt \right) ds \\ = \frac{1}{(k+1)^3 + 2/(k+1)} \sum_{n=n_0}^k \frac{4n^2}{3} \rightarrow \frac{4}{9} \quad (k \rightarrow +\infty). \end{aligned}$$

This implies that $f \notin PSAP_\omega^p(\mathbb{R}, \mathbb{R})$.

Now, take $\rho(t) = 1/t^4$ and $t \neq 0$. Again, by the same calculation as in [9, Example 2.2], we obtain $f \in PSAP_\omega^p(\mathbb{R}, \mathbb{R}, \rho)$.

Theorem 1 [9]. $PSAP_\omega^p(\mathbb{R}, \mathbb{R}^n, \rho)$, where $\rho \in U_\infty$, with the norm $\|\cdot\|_{S^p}$ is a Banach space.

P r o o f. The proof is similar to that of [9, Theorem 3.2], where weighted S^p -pseudo S -asymptotically periodic function is defined on \mathbb{R}_+ , so it is omitted here. \square

Definition 7. Let $\rho \in U_\infty$. A function $f : \mathbb{R} \times \mathbb{R}_+ \times \mathbb{R}_+^n \rightarrow \mathbb{R}$ is called weighted S^p -pseudo S -asymptotically ω -periodic in $s \in \mathbb{R}$ for all $(\sigma, x) \in \mathbb{R}_+ \times \mathbb{R}_+^n$ if $f(\cdot, \sigma, x) \in BS^p(\mathbb{R}, \mathbb{R}^n)$ and

$$\begin{aligned} \lim_{r \rightarrow +\infty} \frac{1}{m^+(r, \rho)} \int_0^r \rho(t) \left(\int_t^{t+1} \|f(s + \omega, \sigma, x) - f(s, \sigma, x)\|^p ds \right)^{1/p} dt = 0, \\ \lim_{r \rightarrow +\infty} \frac{1}{m^-(r, \rho)} \int_{-r}^0 \rho(t) \left(\int_{t-1}^t \|f(s - \omega, \sigma, x) - f(s, \sigma, x)\|^p ds \right)^{1/p} dt = 0 \end{aligned}$$

for all $(\sigma, x) \in \mathbb{R}_+ \times \mathbb{R}_+^n$. Denote by $PSAP_\omega^p(\mathbb{R} \times \mathbb{R}_+ \times \mathbb{R}_+^n, \mathbb{R}, \rho)$ the set of all such functions.

3. Composition theorem

To study the existence of solutions to system (1.1), we reduce the problem to a fixed point problem of a nonlinear operator. For this, we must prove a composition theorem adapted to our case.

Let $BPSAP_\omega^p(\mathbb{R}, \mathbb{R}^n, \rho)$ be the subset of $PSAP_\omega^p(\mathbb{R}, \mathbb{R}^n, \rho)$ consisting of all bounded functions x , that is,

$$\|x\|_\infty = \sup_{s \in \mathbb{R}} \|x(s)\| < \infty.$$

It is clear that $BPSAP_\omega^p(\mathbb{R}, \mathbb{R}^n, \rho)$ is a Banach space with respect to the norm $\|\cdot\|_{S^p}$.

Let $PSAP_\omega^{p,1}(\mathbb{R} \times \mathbb{R}_+ \times \mathbb{R}_+^n, \mathbb{R}^n, \rho)$ be the subset of the space $PSAP_\omega^p(\mathbb{R} \times \mathbb{R}_+ \times \mathbb{R}_+^n, \mathbb{R}^n, \rho)$ consisting of all functions f such that $f(\cdot, \cdot, u) \in L_{Loc}^{p,1}(\mathbb{R} \times \mathbb{R}_+, \mathbb{R}^n)$ for all $u \in \mathbb{R}_+^n$. For $\rho \in U_\infty$, we further assume that (see [2])

$$(H_\rho) \quad \text{for all } \sigma \in \mathbb{R}, \quad \limsup_{|s| \rightarrow +\infty} \frac{\rho(s + \sigma)}{\rho(s)} < +\infty.$$

Note that hypothesis (H_ρ) implies that, for all $\sigma \in \mathbb{R}_+$,

$$\limsup_{r \rightarrow +\infty} \frac{m^+(r + \sigma, \rho)}{m^+(r, \rho)} < +\infty \quad \text{and} \quad \limsup_{r \rightarrow +\infty} \frac{m^-(r + \sigma, \rho)}{m^-(r, \rho)} < +\infty.$$

Lemma 2. *Let $\rho \in U_\infty$ satisfy hypothesis (H_ρ) . If $f \in PSAP_\omega^p(\mathbb{R}, \mathbb{R}^n, \rho)$, then $f_{-\sigma} \in PSAP_\omega^p(\mathbb{R}, \mathbb{R}^n, \rho)$ for all $\sigma \in \mathbb{R}_+$, where $f_{-\sigma}(s) = f(s - \sigma)$.*

P r o o f. Fix $\sigma \in \mathbb{R}_+$. From assumption (H_ρ) , there exist constants $k, s_0 > 0$ such that, for $|s| \geq s_0$,

$$\frac{\rho(s - \sigma)}{\rho(s)} \leq k, \quad \frac{\rho(s + \sigma)}{\rho(s)} \leq k, \quad \frac{m^-(r + \sigma, \rho)}{m^-(r, \rho)} \leq k, \quad \text{and} \quad \frac{m^+(r + \sigma, \rho)}{m^+(r, \rho)} \leq k.$$

Thus, for $r > s_0 + \sigma$,

$$\begin{aligned} & \frac{1}{m^-(r, \rho)} \int_{-r}^{-\sigma} \rho(t) \left(\int_{t-1}^t \|f_{-\sigma}(s - \omega) - f_{-\sigma}(s)\|^p ds \right)^{1/p} dt \\ &= \frac{1}{m^-(r, \rho)} \int_{-r}^{-s_0 - \sigma} \rho(t) \left(\int_{t-1}^t \|f_{-\sigma}(s - \omega) - f_{-\sigma}(s)\|^p ds \right)^{1/p} dt \\ & \quad + \frac{1}{m^-(r, \rho)} \int_{-s_0 - \sigma}^{-\sigma} \rho(t) \left(\int_{t-1}^t \|f_{-\sigma}(s - \omega) - f_{-\sigma}(s)\|^p ds \right)^{1/p} dt. \end{aligned}$$

It is clear that the following integral is defined:

$$\int_{-s_0 - \sigma}^{-\sigma} \rho(t) \left(\int_{t-1}^t \|f_{-\sigma}(s - \omega) - f_{-\sigma}(s)\|^p ds \right)^{1/p} dt.$$

Therefore, since

$$\begin{aligned} & \lim_{r \rightarrow +\infty} m^-(r, \rho) = +\infty, \\ & \lim_{r \rightarrow +\infty} \frac{1}{m^-(r, \rho)} \int_{-s_0 - \sigma}^{-\sigma} \rho(t) \left(\int_{t-1}^t \|f_{-\sigma}(s - \omega) - f_{-\sigma}(s)\|^p ds \right)^{1/p} dt = 0. \end{aligned}$$

Also, we have

$$\begin{aligned} & \frac{1}{m^-(r, \rho)} \int_{-r}^{-s_0-\sigma} \rho(t) \left(\int_{t-1}^t \|f_{-\sigma}(s-\omega) - f_{-\sigma}(s)\|^p ds \right)^{1/p} dt \\ &= \frac{m^-(r+\sigma, \rho)}{m^-(r, \rho)} \frac{1}{m^-(r+\sigma, \rho)} \int_{-r-\sigma}^{-s_0-2\sigma} \frac{\rho(t+\sigma)}{\rho(t)} \rho(t) \left(\int_{t-1}^t \|f(s-\omega) - f(s)\|^p ds \right)^{1/p} dt \\ &\leq \frac{k^2}{m^-(r+\sigma, \rho)} \int_{-(r+\sigma)}^0 \rho(t) \left(\int_{t-1}^t \|f(s-\omega) - f(s)\|^p ds \right)^{1/p} dt. \end{aligned}$$

Since $f \in PSAP_\omega^p(\mathbb{R}, \mathbb{R}^n, \rho)$, we have

$$\lim_{r \rightarrow +\infty} \frac{k^2}{m^-(r+\sigma, \rho)} \int_{-(r+\sigma)}^0 \rho(t) \left(\int_{t-1}^t \|f(s-\omega) - f(s)\|^p ds \right)^{1/p} dt = 0.$$

Thus,

$$\lim_{r \rightarrow +\infty} \frac{1}{m^-(r, \rho)} \int_{-r}^0 \rho(t) \left(\int_{t-1}^t \|f_{-\sigma}(s-\omega) - f_{-\sigma}(s)\|^p ds \right)^{1/p} dt = 0.$$

Similarly, we obtain

$$\lim_{r \rightarrow +\infty} \frac{1}{m^+(r, \rho)} \int_0^r \rho(t) \left(\int_t^{t+1} \|f(s+\omega) - f(s)\|^p ds \right)^{1/p} dt = 0.$$

We deduce that $f_{-\sigma} \in PSAP_\omega^p(\mathbb{R}, \mathbb{R}^n, \rho)$ for all $\sigma \in \mathbb{R}_+$ (see [9, Theorem 3.1] for more details). \square

Now, let us put forward the following hypothesis, which will be helpful throughout the rest of this paper.

(H_0) For every compact subset $K \subset \mathbb{R}_+^n \setminus \{0\}$, there exist constants $L_K, M_K > 0$ such that

(i) for all $x, u \in K$ and all $(s, \sigma) \in \mathbb{R} \times \mathbb{R}_+$,

$$\|f(s, \sigma, x) - f(s, \sigma, u)\| \leq L_K \|x - u\|;$$

(ii) for all $x \in K$ and all $(s, \sigma) \in \mathbb{R} \times \mathbb{R}_+$,

$$\|f(s, \sigma, x)\| \leq M_K \|x\|.$$

Lemma 3. *Let $\rho \in U_\infty$. Assume that $f \in PSAP_\omega^{p,1}(\mathbb{R} \times \mathbb{R}_+ \times \mathbb{R}_+^n, \mathbb{R}^n, \rho)$ satisfies (H_0), and K_1 and K_2 are compact subsets of $\mathbb{R}_+^n \setminus \{0\}$. Then*

$$\lim_{r \rightarrow +\infty} \frac{1}{m^+(r, \rho)} \int_0^r \rho(t) \left[\int_t^{t+1} \left(\sup_{(\tau, x) \in K} \left\| \int_0^\tau [f(s+\omega, \sigma, x) - f(s, \sigma, x)] d\sigma \right\| \right)^p ds \right]^{1/p} dt = 0,$$

$$\lim_{r \rightarrow +\infty} \frac{1}{m^-(r, \rho)} \int_{-r}^0 \rho(t) \left[\int_{t-1}^t \left(\sup_{(\tau, x) \in K} \left\| \int_0^\tau [f(s-\omega, \sigma, x) - f(s, \sigma, x)] d\sigma \right\| \right)^p ds \right]^{1/p} dt = 0,$$

where $K = K_1 \times K_2$ is a compact subset of $\mathbb{R}_+^n \times \mathbb{R}_+^n$.

P r o o f. Fix $\varepsilon > 0$. Then, there exist $(\tau_1, x_1), \dots, (\tau_m, x_m) \in K = K_1 \times K_2$ such that

$$K \subset \bigcup_{i=1}^m B\left((\tau_i, x_i), \frac{\varepsilon}{|K|}\right),$$

where

$$|K| = \sup_{(\tau, x) \in K} \{\|\tau\| + \|x\|\}.$$

For the above $\varepsilon > 0$, there exists $r_0 > 0$ such that

$$\frac{1}{m^+(r, \rho)} \int_0^r \rho(t) \left(\int_t^{t+1} \|f(s + \omega, \sigma, x_i) - f(s, \sigma, x_i)\|^p ds \right)^{1/p} dt < \frac{\varepsilon}{m} \quad (3.1)$$

for $r > r_0$, $\sigma \geq 0$, and $i \in \{1, 2, \dots, m\}$.

Now, let $(\tau, x) \in K$. Then there exists $i_0 \in \{1, 2, \dots, m\}$ such that

$$\|\tau - \tau_{i_0}\| < \frac{\varepsilon}{|K|} \quad \text{and} \quad \|x - x_{i_0}\| < \frac{\varepsilon}{|K|}.$$

Using (H_0) , for all $r > r_0$, we have

$$\begin{aligned} & \left\| \int_0^\tau [f(s + \omega, \sigma, x) - f(s, \sigma, x)] d\sigma \right\| \\ \leq & \left\| \int_0^\tau f(s + \omega, \sigma, x) d\sigma - \int_0^{\tau_{i_0}} f(s + \omega, \sigma, x_{i_0}) d\sigma \right\| + \left\| \int_0^{\tau_{i_0}} [f(s + \omega, \sigma, x_{i_0}) - f(s, \sigma, x_{i_0})] d\sigma \right\| \\ & + \left\| \int_0^{\tau_{i_0}} f(s, \sigma, x_{i_0}) d\sigma - \int_0^\tau f(s, \sigma, x) d\sigma \right\| \\ \leq & \left\| \int_0^{\tau_{i_0}} [f(s + \omega, \sigma, x) - f(s + \omega, \sigma, x_{i_0})] d\sigma \right\| + \int_0^{\|\tau_{i_0}\|} \|f(s + \omega, \sigma, x_{i_0}) - f(s, \sigma, x_{i_0})\| \\ & + \left\| \int_0^\tau [f(s, \sigma, x_{i_0}) - f(s, \sigma, x)] d\sigma \right\| + \left\| \int_{\tau_{i_0}}^\tau f(s + \omega, \sigma, x) d\sigma \right\| + \left\| \int_\tau^{\tau_{i_0}} f(s, \sigma, x_{i_0}) d\sigma \right\| \\ \leq & \int_0^{\|\tau_{i_0}\|} \|f(s + \omega, \sigma, x_{i_0}) - f(s, \sigma, x_{i_0})\| + 2(L_{K_2} + M_{K_2})\varepsilon. \end{aligned}$$

Minkowski's inequality, Hölder's inequality (see, for instance, [3, Theorem 4.6 and Theorem 4.7]), and (3.1) imply that, for all $r > r_0$,

$$\begin{aligned} & \frac{1}{m^+(r, \rho)} \int_0^r \rho(t) \left[\int_t^{t+1} \left(\sup_{(\tau, x) \in K} \left\| \int_0^\tau [f(s + \omega, \sigma, x) - f(s, \sigma, x)] d\sigma \right\| \right)^p ds \right]^{1/p} dt \\ \leq & \sum_{i=1}^m \|\tau_i\|^{(p-1)/p} \frac{1}{m^+(r, \rho)} \int_0^r \rho(t) \left[\int_0^{\|\tau_i\|} \int_t^{t+1} \|f(s + \omega, \sigma, x_i) - f(s, \sigma, x_i)\|^p ds d\sigma \right]^{1/p} dt \\ & + 2(L_{K_2} + M_{K_2})\varepsilon \\ < & \sum_{i=1}^m \|\tau_i\|^{(p-1)/p} \|\tau_i\|^{1/p} \frac{\varepsilon}{m} + 2(L_{K_2} + M_{K_2})\varepsilon \leq [|K| + 2(L_{K_2} + M_{K_2})]\varepsilon. \end{aligned}$$

This proves the former limit. By the same considerations, we prove the latter limit. \square

Theorem 2. Let $\rho \in U_\infty$ satisfy (H_ρ) . Assume that $\tau, x \in BPSAP_\omega^p(\mathbb{R}, \mathbb{R}_+^n, \rho)$, $\inf_{s \in \mathbb{R}} x(s) > 0$, and $f \in PSAP_\omega^{p,1}(\mathbb{R} \times \mathbb{R}_+ \times \mathbb{R}_+^n, \mathbb{R}^n, \rho)$ satisfy (H_0) . Then, the function $Tx : \mathbb{R} \rightarrow \mathbb{R}^n$ defined as

$$Tx(s) = \int_0^{\tau(s)} f(s, \sigma, x(s - \sigma - l)) d\sigma, \quad l \geq 0,$$

belongs to $BPSAP_\omega^p(\mathbb{R}, \mathbb{R}_+^n, \rho)$.

P r o o f. Since $\tau, x \in BPSAP_\omega^p(\mathbb{R}, \mathbb{R}_+^n, \rho)$, using (H_0) (ii), one can easily show that $Tx(\cdot) \in BS^p(\mathbb{R}, \mathbb{R}^n)$. In addition,

$$\begin{aligned} & \left(\int_t^{t+1} \|Tx(s + \omega) - Tx(s)\|^p ds \right)^{1/p} \\ &= \left(\int_t^{t+1} \left\| \int_0^{\tau(s+\omega)} f(s + \omega, \sigma, x(s + \omega - \sigma - l)) d\sigma - \int_0^{\tau(s)} f(s, \sigma, x(s - \sigma - l)) d\sigma \right\|^p ds \right)^{1/p} \\ &\leq \left(\int_t^{t+1} \left\| \int_0^{\tau(s+\omega)} [f(s + \omega, \sigma, x(s + \omega - \sigma - l)) - f(s, \sigma, x(s + \omega - \sigma - l))] d\sigma \right\|^p ds \right)^{1/p} \\ &\quad + \left(\int_t^{t+1} \left\| \int_0^{\tau(s)} [f(s, \sigma, x(s + \omega - \sigma - l)) - f(s, \sigma, x(s - \sigma - l))] d\sigma \right\|^p ds \right)^{1/p} \\ &\quad + \left(\int_t^{t+1} \left\| \int_{\tau(s)}^{\tau(s+\omega)} f(s, \sigma, x(s + \omega - \sigma - l)) d\sigma \right\|^p ds \right)^{1/p}. \end{aligned}$$

Let

$$K_1 = \overline{\{\tau(s) : s \in \mathbb{R}\}}, \quad K_2 = \overline{\{x(s) : s \in \mathbb{R}\}},$$

and $K = K_1 \times K_2$. Then, we have

$$\begin{aligned} & \int_0^r \rho(t) \left(\int_t^{t+1} \|Tx(s + \omega) - Tx(s)\|^p ds \right)^{1/p} dt \\ &\leq \int_0^r \rho(t) \left[\int_t^{t+1} \left(\sup_{(\tau, x) \in K} \left\| \int_0^\tau [f(s + \omega, \sigma, x) - f(s, \sigma, x)] d\sigma \right\|^p ds \right)^{1/p} dt \right. \\ &\quad \left. + \|\tau\|_\infty^{(p-1)/p} \int_0^r \rho(t) \left[\int_t^{t+1} \int_0^{\|\tau\|_\infty} \|f(s, \sigma, x(s + \omega - \sigma - l)) - f(s, \sigma, x(s - \sigma - l))\|^p d\sigma ds \right]^{1/p} dt \right. \\ &\quad \left. + M \|x\|_\infty \int_0^r \rho(t) \left(\int_t^{t+1} \|\tau(s + \omega) - \tau(s)\|^p ds \right)^{1/p} dt. \right. \end{aligned}$$

From (H_0) , Lemma 2, and Lemma 3, we obtain

$$\lim_{r \rightarrow +\infty} \frac{1}{m^+(r, \rho)} \int_0^r \rho(t) \left[\int_t^{t+1} \|Tx(s + \omega) - Tx(s)\|^p ds \right]^{1/p} dt = 0.$$

Similarly, we get

$$\lim_{r \rightarrow +\infty} \frac{1}{m^-(r, \rho)} \int_{-r}^0 \rho(t) \left[\int_{t-1}^t \|Tx(s - \omega) - Tx(s)\|^p ds \right]^{1/p} dt = 0.$$

□

We close this section with the following lemma, which, together with Lemma 2 and Theorem 2, are necessary for the sequel.

Lemma 4. *Let $\rho \in U_\infty$. Assume that $f, g \in BPSAP_\omega^p(\mathbb{R}, \mathbb{R}, \rho)$, then the product $f \cdot g$ belongs to $BPSAP_\omega^p(\mathbb{R}, \mathbb{R}, \rho)$.*

P r o o f. Since $f, g \in PSAP_\omega^p(\mathbb{R}, \mathbb{R}, \rho)$ are bounded, we have

$$\begin{aligned} & \frac{1}{m^+(r, \rho)} \int_0^r \rho(t) \left(\int_t^{t+1} |f(s+\omega)g(s+\omega) - f(s)g(s)|^p ds \right)^{1/p} dt \\ & \leq \frac{1}{m^+(r, \rho)} \int_0^r \rho(t) \left(\int_t^{t+1} |f(s+\omega)g(s+\omega) - f(s+\omega)g(s)|^p ds \right)^{1/p} dt \\ & \quad + \frac{1}{m^+(r, \rho)} \int_0^r \rho(t) \left(\int_t^{t+1} |f(s+\omega)g(s) - f(s)g(s)|^p ds \right)^{1/p} dt \\ & \leq \frac{\|f\|_\infty}{m^+(r, \rho)} \int_0^r \rho(t) \left(\int_t^{t+1} |g(s+\omega) - g(s)|^p ds \right)^{1/p} dt \\ & \quad + \frac{\|g\|_\infty}{m^+(r, \rho)} \int_0^r \rho(t) \left(\int_t^{t+1} |f(s+\omega) - f(s)|^p ds \right)^{1/p} dt. \end{aligned}$$

Thus,

$$\lim_{r \rightarrow +\infty} \frac{1}{m^+(r, \rho)} \int_0^r \rho(t) \left(\int_t^{t+1} |f(s+\omega)g(s+\omega) - f(s)g(s)|^p ds \right)^{1/p} dt = 0,$$

and similarly we get

$$\lim_{r \rightarrow +\infty} \frac{1}{m^-(r, \rho)} \int_{-r}^0 \rho(t) \left(\int_{t-1}^t |f(s-\omega)g(s-\omega) - f(s)g(s)|^p ds \right)^{1/p} dt = 0.$$

□

4. Existence theorem

In this section, we give sufficient conditions for system (1.1) to have a solution in the Banach space $BPSAP_\omega^p(\mathbb{R}, \mathbb{R}, \rho) \times BPSAP_\omega^p(\mathbb{R}, \mathbb{R}, \rho)$. Suppose that $\rho \in U_\infty$ satisfies assumption (H_ρ) . We put forward the following hypotheses on the components of system (1.1), which are essential in the proof of our existence result.

- (H_1) $\tau_i, \alpha_i \in BPSAP_\omega^p(\mathbb{R}, \mathbb{R}, \rho)$ ($i = 1, 2$) are nonnegative functions.
- (H_2) $F = (f, g) \in PSAP_\omega^{p,1}(\mathbb{R} \times \mathbb{R}_+ \times \mathbb{R}_+^2, \mathbb{R}_+^2, \rho)$ is such that, for every $(s, \sigma, x, y) \in \mathbb{R} \times \mathbb{R}_+ \times \mathbb{R}_+ \times \mathbb{R}_+$, $f(s, \sigma, \cdot, y)$ and $g(s, \sigma, x, \cdot)$ are nondecreasing, and $f(s, \sigma, x, \cdot)$ and $g(s, \sigma, \cdot, y)$ are nonincreasing.
- (H_3) There exist positive-valued functions ξ on $(0, 1)$ and φ_i on $(0, 1) \times \mathbb{R}_+ \times \mathbb{R}_+$ ($i = 1, 2$) such that
- (i) $\xi : (0, 1) \rightarrow (0, 1)$ is a surjection;
 - (ii) for all $x, y \in (0, +\infty)$, all $(s, \sigma) \in \mathbb{R} \times \mathbb{R}_+$, and all $\gamma \in (0, 1)$,

$$\begin{aligned} f\left(s, \sigma, \xi(\gamma)x, \frac{1}{\xi(\gamma)}y\right) & \geq \varphi_1(\gamma, x, y)f(s, \sigma, x, y), \\ g\left(s, \sigma, \frac{1}{\xi(\gamma)}x, \xi(\gamma)y\right) & \geq \varphi_2(\gamma, x, y)g(s, \sigma, x, y). \end{aligned}$$

(H₄) There exist constants $M > \varepsilon > 0$ and $N > \delta > 0$ such that, for all $s \in \mathbb{R}$,

$$\varepsilon \leq \alpha_1(s)\varepsilon^\eta + \int_0^{\tau_1(s)} f(s, \sigma, \varepsilon, N) d\sigma \leq \alpha_1(s)M^\eta + \int_0^{\tau_1(s)} f(s, \sigma, M, \delta) d\sigma \leq M$$

and

$$\delta \leq \alpha_2(s)\delta^\nu + \int_0^{\tau_2(s)} g(s, \sigma, M, \delta) d\sigma \leq \alpha_2(s)N^\nu + \int_0^{\tau_2(s)} g(s, \sigma, \varepsilon, N) d\sigma \leq N.$$

(H₅) For every $\gamma \in (0, 1)$,

$$\begin{aligned} \underline{\varphi}_1(\gamma) &= \inf_{\substack{x \in [\varepsilon^2/M, M], \\ y \in [\delta^2/N, N]}} \varphi_1(\gamma, x, y) > \xi(\gamma) + r_1 [\xi(\gamma) - (\xi(\gamma))^\eta], \\ \underline{\varphi}_2(\gamma) &= \inf_{\substack{x \in [\varepsilon^2/M, M], \\ y \in [\delta^2/N, N]}} \varphi_2(\gamma, x, y) > \xi(\gamma) + r_2 [\xi(\gamma) - (\xi(\gamma))^\nu], \end{aligned}$$

where

$$\begin{aligned} r_1 &= \frac{\bar{\alpha}_1 M^\eta}{\inf_{s \in \mathbb{R}} \int_0^{\tau_1(s)} f(s, \sigma, \varepsilon^2/M, N) d\sigma} < +\infty, & r_2 &= \frac{\bar{\alpha}_2 N^\nu}{\inf_{s \in \mathbb{R}} \int_0^{\tau_2(s)} g(s, \sigma, M, \delta^2/N) d\sigma} < +\infty, \\ & \text{and } \bar{\alpha}_i &= \sup_{s \in \mathbb{R}} \alpha_i(s), & i &= 1, 2. \end{aligned}$$

Theorem 3. Let $F = (f, g) \in PSAP_\omega^{p,1}(\mathbb{R} \times \mathbb{R}_+ \times \mathbb{R}_+^2, \mathbb{R}_+^2, \rho)$ be a function satisfying (H₀). Assume that (H₁)–(H₅) hold. Then system (1.1) has a bounded positive weighted S^p -pseudo S -asymptotically periodic solution (x^*, y^*) , that is, $x^*, y^* \in BPSAP_\omega^p(\mathbb{R}, \mathbb{R}, \rho)$ are such that $\inf_{s \in \mathbb{R}} x^*(s) > 0$ and $\inf_{s \in \mathbb{R}} y^*(s) > 0$.

P r o o f. Consider the following set in the Banach space $PSAP_\omega^p(\mathbb{R}; \mathbb{R}, \rho)$:

$$K = \{x \in PSAP_\omega^p(\mathbb{R}; \mathbb{R}, \rho) : \inf_{s \in \mathbb{R}} x(s) > 0\}.$$

Consider nonlinear operators $B = (B_1, B_2)$ and $C = (C_1, C_2)$ defined as

$$\begin{aligned} B_1(x, y)(s) &= \int_0^{\tau_1(s)} f(s, \sigma, x(s - \sigma - l), y(s - \sigma - l)) d\sigma, \\ B_2(x, y)(s) &= \int_0^{\tau_2(s)} g(s, \sigma, x(s - \sigma - l), y(s - \sigma - l)) d\sigma, \\ C_1(x)(s) &= \alpha_1(s)x^\eta(s - l) \quad \text{and} \quad C_2(y)(s) = \alpha_2(s)y^\nu(s - l), \end{aligned}$$

for all $(x, y) \in K \times K$ and all $s \in \mathbb{R}$. Let

$$\begin{aligned} A_1(x, y)(s) &= B_1(x, y)(s) + C_1(x)(s), \\ A_2(x, y)(s) &= B_2(x, y)(s) + C_2(y)(s), \end{aligned}$$

and

$$A(x, y)(s) = (A_1(x, y)(s), A_2(x, y)(s))$$

for all $x, y \in K$ and all $s \in \mathbb{R}$.

Now, for $(x, y) \in K \times K$ such that

$$\frac{\varepsilon^2}{M} \leq x(s) \leq M \quad \text{and} \quad \frac{\delta^2}{N} \leq y(s) \leq N$$

for all $s \in \mathbb{R}$, we have

$$C_1(x)(s) \leq \bar{\alpha}_1 M^\eta = r_1 \inf_{s \in \mathbb{R}} \int_0^{\tau_1(s)} f\left(s, \sigma, \frac{\varepsilon^2}{M}, N\right) d\sigma \leq r_1 B_1(x, y)(s), \quad s \in \mathbb{R},$$

and

$$C_2(y)(s) \leq \bar{\alpha}_2 N^\nu = r_2 \inf_{s \in \mathbb{R}} \int_0^{\tau_2(s)} g\left(s, \sigma, M, \frac{\delta^2}{N}\right) d\sigma \leq r_2 B_2(x, y)(s), \quad s \in \mathbb{R}.$$

It follows that, for all $(x, y) \in K \times K$ such that

$$\frac{\varepsilon^2}{M} \leq x(s) \leq M, \quad \frac{\delta^2}{N} \leq y(s) \leq N, \quad s \in \mathbb{R},$$

and all $\gamma \in (0, 1)$,

$$\begin{aligned} A_1\left(\xi(\gamma)x, \frac{1}{\xi(\gamma)}y\right)(s) &= B_1\left(\xi(\gamma)x, \frac{1}{\xi(\gamma)}y\right)(s) + C_1(\xi(\gamma)x)(s) \\ &\geq \underline{\varphi}_1(\gamma)B_1(x, y)(s) + (\xi(\gamma))^\eta C_1(x)(s) \\ &= \xi(\gamma)A_1(x, y)(s) + \underline{\varphi}_1(\gamma)B_1(x, y)(s) + (\xi(\gamma))^\eta C_1(x)(s) - \xi(\gamma)A_1(x, y)(s) \\ &\geq \xi(\gamma)A_1(x, y)(s) + [\underline{\varphi}_1(\gamma) - \xi(\gamma)]B_1(x, y)(s) - [\xi(\gamma) - (\xi(\gamma))^\eta]r_1 B_1(x, y)(s) \\ &\geq \left[\xi(\gamma) + \frac{\underline{\varphi}_1(\gamma) - \xi(\gamma) - [\xi(\gamma) - (\xi(\gamma))^\eta]r_1}{1 + r_1}\right]A_1(x, y)(s) = \psi_1(\gamma)A_1(x, y)(s). \end{aligned}$$

Similarly, we obtain

$$A_2\left(\frac{1}{\xi(\gamma)}x, \xi(\gamma)y\right)(s) \geq \psi_2(\gamma)A_2(x, y)(s),$$

where

$$\begin{aligned} \psi_1(\gamma) &= \xi(\gamma) + \frac{\underline{\varphi}_1(\gamma) - \xi(\gamma) - [\xi(\gamma) - (\xi(\gamma))^\eta]r_1}{1 + r_1} > \xi(\gamma), \\ \psi_2(\gamma) &= \xi(\gamma) + \frac{\underline{\varphi}_2(\gamma) - \xi(\gamma) - [\xi(\gamma) - (\xi(\gamma))^\nu]r_2}{1 + r_2} > \xi(\gamma) \end{aligned}$$

for all $\gamma \in (0, 1)$ by (H_5) . Take

$$\begin{aligned} x_0(s) &= \varepsilon, & u_0(s) &= M, \\ y_0(s) &= \delta, & v_0(s) &= N \end{aligned}$$

and consider the sequences

$$\begin{aligned} x_k(s) &= A_1(x_{k-1}, v_{k-1})(s), & u_k(s) &= A_1(u_{k-1}, y_{k-1})(s), \\ y_k(s) &= A_2(u_{k-1}, y_{k-1})(s), & v_k(s) &= A_2(x_{k-1}, v_{k-1})(s). \end{aligned}$$

From (H_4) and the monotony of the functions f and g assumed in (H_2) , it is easy to show by induction that, for all $s \in \mathbb{R}$,

$$\begin{aligned} \varepsilon &\leq x_1(s) \leq x_2(s) \leq \cdots \leq x_k(s) \leq \cdots \leq u_k(s) \leq \cdots \leq u_2(s) \leq u_1(s) \leq M, \\ \delta &\leq y_1(s) \leq y_2(s) \leq \cdots \leq y_k(s) \leq \cdots \leq v_k(s) \leq \cdots \leq v_2(s) \leq v_1(s) \leq N. \end{aligned}$$

Now, let

$$\mu_k = \sup \{ \mu > 0 : x_k(s) \geq \mu u_k(s) \text{ and } y_k(s) \geq \mu v_k(s), s \in \mathbb{R} \}.$$

Then $x_k(s) \geq \mu_k u_k(s)$ and $y_k(s) \geq \mu_k v_k(s)$ for all $k \geq 0$.

It follows that

$$\begin{aligned} x_{k+1}(s) &\geq x_k(s) \geq \mu_k u_k(s) \geq \mu_k u_{k+1}(s), \\ y_{k+1}(s) &\geq y_k(s) \geq \mu_k v_k(s) \geq \mu_k v_{k+1}(s) \end{aligned}$$

for all $s \in \mathbb{R}$, which implies that $\mu_{k+1} \geq \mu_k$ and

$$\max \left(\frac{\varepsilon}{M}, \frac{\delta}{N} \right) \leq \mu_k \leq 1, \quad k \geq 0.$$

Therefore, $(\mu_k)_k$ is a convergent sequence. Let us set $\mu^* = \lim_{k \rightarrow +\infty} \mu_k$ and prove that $\mu^* = 1$. Indeed, if we suppose to the contrary that $\mu^* < 1$, then by (H_3) (i), there exist $\gamma^* \in (0, 1)$ such that $\mu^* = \xi(\gamma^*)$. We distinguish two cases.

Case 1. There exists integer k_0 such that $\mu_{k_0} = \mu^*$. Then, $\mu_k = \mu^*$ for all $k \geq k_0$. Hence, for all $k \geq k_0$ and all $s \in \mathbb{R}$,

$$x_{k+1} = A_1(x_k, v_k)(s) \geq A_1 \left(\mu_k u_k, \frac{1}{\mu_k} y_k \right) (s) = A_1 \left(\xi(\gamma^*) u_k, \frac{1}{\xi(\gamma^*)} y_k \right) (s) \geq \psi_1(\gamma^*) u_{k+1}(s).$$

We also conclude that $y_{k+1}(s) \geq \psi_2(\gamma^*) v_{k+1}(s)$ for all $s \in \mathbb{R}$.

Thus,

$$\mu_{k+1} = \mu^* \geq \max\{\psi_1(\gamma^*), \psi_2(\gamma^*)\} > \xi(\gamma^*) = \mu^*.$$

This is a contradiction.

Case 2. For all integer k , $\mu_k < \mu^*$. Again, by (H_3) (i), there exist $\gamma_k \in (0, 1)$ such that

$$\xi(\gamma_k) = \frac{\mu_k}{\mu^*} \in (0, 1).$$

Then, for all $s \in \mathbb{R}$, we have

$$\begin{aligned} x_{k+1}(s) &= A_1(x_k, v_k)(s) \geq A_1 \left(\mu_k u_k, \frac{1}{\mu_k} y_k \right) (s) = A_1 \left(\frac{\mu_k}{\mu^*} \mu^* u_k, \frac{\mu^*}{\mu_k} \frac{1}{\mu^*} y_k \right) (s) \\ &= A_1 \left(\xi(\gamma_k) \mu^* u_k, \frac{1}{\xi(\gamma_k)} \frac{1}{\mu^*} y_k \right) (s) \geq \psi_1(\gamma_k) \psi_1(\gamma^*) u_{k+1}(s). \end{aligned}$$

Similarly, we obtain

$$y_{k+1}(s) \geq \psi_2(\gamma_k) \psi_2(\gamma^*) v_{k+1}(s).$$

Thus, by the definition of μ_k , we have

$$\mu_{k+1} \geq \max \{ \psi_1(\gamma_k) \psi_1(\gamma^*), \psi_2(\gamma_k) \psi_2(\gamma^*) \} \geq \max \left\{ \frac{\mu_k}{\mu^*} \psi_1(\gamma^*), \frac{\mu_k}{\mu^*} \psi_2(\gamma^*) \right\}.$$

Let $k \rightarrow +\infty$, then

$$\mu^* \geq \max\{\psi_1(\gamma^*), \psi_2(\gamma^*)\} > \xi(\gamma^*) = \mu^*.$$

This is also a contradiction.

On the other hand, using hypotheses (H_1) and (H_2) combined with Lemma 2, Theorem 2, and Lemma 4, one can show that $x_k, u_k, y_k, v_k \in BPSAP_\omega^p(\mathbb{R}; \mathbb{R}, \rho)$ for all integer k .

In addition, for integer i and j such that $i > j$ and for all $s \in \mathbb{R}$, we have

$$\begin{aligned} 0 \leq x_i(s) - x_j(s) &\leq u_i(s) - x_j(s) \leq u_j(s) - x_j(s) \leq (1 - \mu_j)u_j(s) \leq (1 - \mu_j)M, \\ 0 \leq y_i(s) - y_j(s) &\leq v_i(s) - y_j(s) \leq v_j(s) - y_j(s) \leq (1 - \mu_j)v_j(s) \leq (1 - \mu_j)N. \end{aligned}$$

It follows that

$$\|x_i - x_j\|_{S^p} \leq (1 - \mu_j)M \rightarrow 0, \quad \|y_i - y_j\|_{S^p} \leq (1 - \mu_j)N \rightarrow 0 \quad (\text{as } j \rightarrow +\infty).$$

This means that $(x_k)_k$ and $(y_k)_k$ are Cauchy sequences in $BPSAP_\omega^p(\mathbb{R}; \mathbb{R}, \rho)$, and thus, there exist $x^*, y^* \in BPSAP_\omega^p(\mathbb{R}; \mathbb{R}, \rho)$ such that $x_k \rightarrow x^*$ and $y_k \rightarrow y^*$ in $BPSAP_\omega^p(\mathbb{R}; \mathbb{R}, \rho)$ as $k \rightarrow +\infty$. Also, one can easily see that $u_k \rightarrow x^*$ and $v_k \rightarrow y^*$ in $BPSAP_\omega^p(\mathbb{R}; \mathbb{R}, \rho)$ as $k \rightarrow +\infty$. Moreover, for all integer k and all $s \in \mathbb{R}$,

$$x_k(s) \leq x^*(s) \leq u_k(s) \quad \text{and} \quad y_k(s) \leq y^*(s) \leq v_k(s).$$

Finally, we have

$$\begin{aligned} x_{k+1}(s) &= A_1(x_k, v_k)(s) \leq A_1(x^*, y^*)(s) \leq A_1(u_k, y_k)(s) = u_{k+1}(s), \\ y_{k+1}(s) &= A_2(u_k, y_k)(s) \leq A_2(x^*, y^*)(s) \leq A_2(x_k, v_k)(s) = v_{k+1}(s). \end{aligned}$$

If $k \rightarrow +\infty$, we get

$$A(x^*, y^*) = (A_1(x^*, y^*), A_2(x^*, y^*)) = (x^*, y^*).$$

That is, (x^*, y^*) is a positive solution of system (1.1) in $BPSAP_\omega^p(\mathbb{R}; \mathbb{R}, \rho) \times BPSAP_\omega^p(\mathbb{R}; \mathbb{R}, \rho)$. The proof is complete. \square

Example 2. Let us choose

$$\eta = \frac{3}{2}, \quad \nu = \frac{4}{3}, \quad \alpha_1 := \frac{1}{10}, \quad \alpha_2 := \frac{1}{6}, \quad \tau_1 = \tau_2 := 1.$$

Consider functions $a, b \in PSAP_\omega^{p,1}(\mathbb{R}, \mathbb{R}, \rho)$ such that

$$\begin{aligned} \frac{9}{10} \sqrt{\frac{12}{19}} &\leq \inf_{s \in \mathbb{R}} a(s) \leq \sup_{s \in \mathbb{R}} a(s) \leq \frac{8}{5} \sqrt{\frac{9}{11}}, \\ \frac{5}{6} \left(\frac{5}{2}\right)^{1/5} &\leq \inf_{s \in \mathbb{R}} b(s) \leq \sup_{s \in \mathbb{R}} b(s) \leq \frac{4}{3} \left(\frac{2}{3}\right)^{1/5} \end{aligned}$$

and take

$$f(s, \sigma, x, y) = a(s - \sigma) \sqrt{x + \frac{1}{4} + \frac{1}{y+1}}, \quad g(s, \sigma, x, y) = b(s - \sigma) \sqrt[5]{\frac{y+1}{x^2+1}}.$$

Then, using the Mean value Theorem, one easily verifies that f and g satisfy $(H_0)(i)$, furthermore $(H_0)(ii)$ is obvious. Also, (H_1) and (H_2) are easy to check.

Hypothesis (H_3) is satisfied for

$$\xi(\lambda) := \lambda, \quad \varphi_1(\lambda, x, y) := \sqrt{\lambda}, \quad \text{and} \quad \varphi_2(\lambda, x, y) := \sqrt[5]{\lambda^3},$$

whenever $\lambda \in (0, 1)$ and $x, y \in (0, +\infty)$.

Finally, (H_4) and (H_5) are satisfied for $\varepsilon = \delta = 1$, $M = N = 2$,

$$r_1 = \frac{2^{3/2}}{10 \inf_{s \in \mathbb{R}} \int_0^1 f(s, \sigma, 1/2, 2) d\sigma} \leq 1, \quad \text{and} \quad r_2 = \frac{2^{4/3}}{6 \inf_{s \in \mathbb{R}} \int_0^1 g(s, \sigma, 2, 1/2) d\sigma} \leq 1.$$

Thus, all the assumptions of Theorem 3 hold. Therefore, system (1.1) with the above data has the desired solution.

5. Conclusion

We have extended for the first time the study of a nonlinear integral equation in certain spaces to multidimensional systems in the space of weighted S^p -pseudo S -asymptotically ω -periodic functions. Moreover, we have made a change to the definition of this type of function, especially in the domain of definition, which we considered as \mathbb{R} instead of \mathbb{R}^+ . Our perspective in the future is to extend such a study to the abstract case where the dimension is infinite.

REFERENCES

1. Blot J., Cieutat P., N'Guérékata G. M. S -asymptotically ω -periodic functions and applications to evolution equations. *Afr. Diaspora J. Math.*, 2011. Vol. 12, No. 2. P. 113–121.
2. Blot J., Mophou G. M., N'Guérékata G. M., Pennequin D. Weighted pseudo almost automorphic functions and applications to abstract differential equations. *Nonlinear Anal.*, 2009. Vol. 71. P. 903–909. DOI: [10.1016/j.na.2008.10.113](https://doi.org/10.1016/j.na.2008.10.113)
3. Brezis H. *Functional Analysis, Sobolev Spaces and Partial Differential Equations*, 1st edition. NY: Springer, 2010. 600 p. DOI: [10.1007/978-0-387-70914-7](https://doi.org/10.1007/978-0-387-70914-7)
4. Cooke K. L., Kaplan J. L. A periodicity threshold theorem for epidemics and population growth. *Math. Biosci.*, 1976. Vol. 31, No. 1–2. P. 87–104. DOI: [10.1016/0025-5564\(76\)90042-0](https://doi.org/10.1016/0025-5564(76)90042-0)
5. Cuevas C., de Souza J. C. S -asymptotically ω -periodic solutions of semilinear fractional integro-differential equations. *Appl. Math. Lett.*, 2009. Vol. 22, No. 6. P. 865–870. DOI: [10.1016/j.aml.2008.07.013](https://doi.org/10.1016/j.aml.2008.07.013)
6. Diagana T., Mophou G. M., N'Guérékata G. M. Existence of weighted pseudo-almost periodic solutions to some classes of differential equations with S^p -weighted pseudo-almost periodic coefficients. *Nonlinear Anal.*, 2010. Vol. 72, No. 1. P. 430–438. DOI: [10.1016/j.na.2009.06.077](https://doi.org/10.1016/j.na.2009.06.077)
7. Dimbour W., Mado J.-C. S -asymptotically ω -periodic solution for a nonlinear differential equation with piecewise constant argument in a Banach space. *CUBO. Math. J.*, 2014. Vol. 16, No. 3. P. 55–65. URL: <https://hal.science/hal-02067049>
8. Dimbour W., Manou-Abi S. M. Asymptotically ω -periodic functions in the Stepanov sense and its application for an advanced differential equation with piecewise constant argument in a Banach space. *Mediterr. J. Math.*, 2018. Vol. 15. Art. no. 25. DOI: [10.1007/s00009-018-1071-6](https://doi.org/10.1007/s00009-018-1071-6)
9. He B., Wang Q.-R., Cao J.-F. Weighted S^p -pseudo S -asymptotic periodicity and applications to Volterra integral equations. *Appl. Math. Comput.*, 2020. Vol. 380. P. 125–275. DOI: [10.1016/j.amc.2020.125275](https://doi.org/10.1016/j.amc.2020.125275)
10. Henríquez H. R., Pierri M., Táboas P. On S -asymptotically ω -periodic functions on Banach spaces and applications. *J. Math. Anal. Appl.*, 2008. Vol. 343. P. 1119–1130. DOI: [10.1016/j.jmaa.2008.02.023](https://doi.org/10.1016/j.jmaa.2008.02.023)
11. Lee H. M., Jang H. H., Yun C. M. S -asymptotically ω -periodic mild solutions for the systems of differential equations with piecewise constant argument in Banach spaces. *J. Chungcheong Math. Soc.*, 2018. Vol. 31, No. 1. P. 13–27. DOI: [10.14403/jcms.2018.31.1.13](https://doi.org/10.14403/jcms.2018.31.1.13)
12. N'Guérékata G. M., Pankov A. Stepanov-like almost automorphic functions and monotone evolution equations. *Nonlinear Anal.*, 2008. Vol. 68, No. 9. P. 2658–2667. DOI: [10.1016/j.na.2007.02.012](https://doi.org/10.1016/j.na.2007.02.012)
13. Sadrati A., Zertiti A. A study of systems of nonlinear delay integral equations by using the method of upper and lower solutions. *Int. J. Math. Comput.*, 2012. Vol. 17, No. 4. P. 93–102.
14. Sadrati A., Zertiti A. A topological methods for Existence and multiplicity of positive solutions for some systems of nonlinear delay integral equations. *Int. J. Math. Stat.*, 2013. Vol. 13, No. 1. P. 47–55.
15. Sadrati A., Zertiti A. Existence and uniqueness of positive almost periodic solution for systems of nonlinear delay integral equations. *Electron. J. Diff. Equ.*, 2015. Vol. 2015, No. 116. P. 1–12.
16. Sadrati A., Zertiti A. The Existence and uniqueness of positive weighted pseudo almost automorphic solution for some systems of neutral nonlinear delay integral equations. *Int. J. Appl. Math.*, 2016. Vol. 29, No. 3. P. 331–347. DOI: [10.12732/ijam.v29i3.5](https://doi.org/10.12732/ijam.v29i3.5)
17. Xia Z. N. Weighted pseudo asymptotically periodic mild solutions of evolution equations. *Acta. Math. Sin.-English Ser.*, 2015. Vol. 31, No. 8. P. 1215–1232. DOI: [10.1007/s10114-015-4727-1](https://doi.org/10.1007/s10114-015-4727-1)
18. Zhao J.-Y., Ding H.-S., N'Guérékata G. M. S -asymptotically periodic solutions for an epidemic model with superlinear perturbation. *Adv. Differ. Equ.*, 2016. Vol. 2016. Art. no. 221. DOI: [10.1186/s13662-016-0954-8](https://doi.org/10.1186/s13662-016-0954-8)

ON THE PROPERTIES OF THE SET OF TRAJECTORIES OF THE NONLINEAR CONTROL SYSTEM WITH QUADRATIC INTEGRAL CONSTRAINT ON THE CONTROL FUNCTIONS

Anar Huseyin[†], Nesir Huseyin^{††}

Sivas Cumhuriyet University,
58140 Merkez, Sivas, Turkey

[†]ahuseyin@cumhuriyet.edu.tr ^{††}nhuseyin@cumhuriyet.edu.tr

Abstract: In this paper the control system described by a nonlinear differential equation is studied. It is assumed that the control functions have a quadratic integral constraint, more precisely, the admissible control functions are chosen from the ellipsoid of the space $L_2([t_0, \theta]; \mathbb{R}^m)$. Different properties of the set of trajectories are investigated. It is proved that a small perturbation of the set of control functions causes also appropriate small perturbation of the set of trajectories. It is also shown that the set of trajectories has a small change if along with the integral constraint on the control functions, a sufficiently large norm type geometric constraint on the control functions is introduced. It is established that every trajectory is robust with respect to the fast consumption of the remaining control resource, and hence every trajectory of the system can be approximated by a trajectory generated by full consumption of the total control resource.

Keywords: Nonlinear control system, Quadratic integral constraint, Set of trajectories, Robustness.

1. Introduction

The control systems described by nonlinear differential equations are investigated in a vast number of papers. Depending on the character of the control efforts the control systems are classified as a) the control systems with geometric constraint on the control functions; b) the control systems with integral constraint on the control functions; and c) the control systems with mixed constraints on the control functions which include both the geometric and the integral constraints on the control functions. The geometric constraints on the control functions appear in the case when the control resource is not exhausted by consumption. But, if the control resource is exhausted by consumption, say as energy, food, fuel, finance, etc., then the integral constraints on the control functions is inevitable (see, e.g., [1, 2, 9, 12, 15, 16]). For example, the behaviour of the flying objects with rapidly changing mass is described as a control system with integral constraint on the control functions (see, e.g., [2, 12]).

One of the important notions of the control systems theory is the set of trajectories and attainable set concepts. Attainable set of the system at the given instant of time consists of points to which arrive the trajectories of the system and can be defined as a section of the set of trajectories at the given instant of time. Different topological properties and approximate construction methods of the set of trajectories described by various types of the integral and differential equations, where the control functions have integral constraints, are considered in papers [4–8, 11, 13, 14]. In papers [4, 5, 11, 14] the compactness, closedness, path-connectedness properties and approximate construction methods of the set of trajectories and attainable sets of the control systems which are affine with respect to the control vector are discussed. In papers [6–8, 13] the same problems are investigated for nonlinear control systems. In presented paper the properties of the set of trajec-

ries of the nonlinear control systems are studied where the admissible control functions are chosen from the ellipsoid of the space L_2 .

The paper is organized as follows. In Section 2, the basic conditions which have to satisfy the system's equation are formulated and preliminary properties of the system's trajectories are given. In Section 3 it is shown that introduction of the sufficiently large norm type constraint along with integral constraint and a small perturbation of the given ellipsoid, which characterizes the integral constraint, induce a small change of the set of trajectories (Theorem 2). A perturbation evaluation for the set of trajectories is presented. In Section 4 it is proved that every trajectory is robust with respect to the fast and full consumption of remaining control resource (Proposition 7). Applying this result it is proved that every trajectory can be approximated by the trajectory generated by full consumption of the total control resource (Theorem 3).

2. The system's dynamics

Consider control system described by nonlinear ordinary differential equation

$$\dot{x}(t) = f(t, x(t), u(t)), \quad x(t_0) = x_0 \quad (2.1)$$

where $x(t) \in \mathbb{R}^n$ is the phase state vector, $u(t) \in \mathbb{R}^m$ is the control vector, $t \in [t_0, \theta]$ is the time.

Let $B(\cdot) : [t_0, \theta] \rightarrow \mathbb{R}^{m \times m}$ be a continuous matrix function and $B(t)$ be a positive definite $m \times m$ matrix for every $t \in [t_0, \theta]$. For given $\varepsilon \in [0, 1]$ and $\alpha > 0$ we denote

$$\begin{aligned} U_\varepsilon &= \left\{ u(\cdot) \in L_2([t_0, \theta]; \mathbb{R}^m) : \int_{t_0}^{\theta} \langle B(t)u(t), u(t) \rangle dt \leq 1 + \varepsilon \right\}, \\ U_\varepsilon^\alpha &= \{ u(\cdot) \in U_\varepsilon : \|u(t)\| \leq \alpha \text{ for almost all } t \in [t_0, \theta] \}, \\ U_0^* &= \left\{ u(\cdot) \in L_2([t_0, \theta]; \mathbb{R}^m) : \int_{t_0}^{\theta} \langle B(t)u(t), u(t) \rangle dt = 1 \right\}, \end{aligned}$$

where $L_2([t_0, \theta]; \mathbb{R}^m)$ is the space of Lebesgue measurable functions $u(\cdot) : [t_0, \theta] \rightarrow \mathbb{R}^m$ such that

$$\|u(\cdot)\|_2 < +\infty, \quad \|u(\cdot)\|_2 = \left(\int_{t_0}^{\theta} \|u(t)\|^2 ds \right)^{1/2},$$

$\|\cdot\|$ denotes the Euclidean norm, $\langle \cdot, \cdot \rangle$ stands for inner product.

Proposition 1. *The sets U_ε and U_ε^α are bounded, closed and convex subsets of the space $L_2([t_0, \theta]; \mathbb{R}^m)$. The set U_0^* is bounded and closed subset of the space $L_2([t_0, \theta]; \mathbb{R}^m)$.*

It is not difficult to show that there exists $c_* > 0$ such that the inequality

$$\|u(\cdot)\|_2 \leq c_* \quad (2.2)$$

is satisfied for every $u(\cdot) \in U_\varepsilon$ and $\varepsilon \in [0, 1]$.

It is assumed that the function $f(\cdot, \cdot, \cdot) : [t_0, \theta] \times \mathbb{R}^n \times \mathbb{R}^m \rightarrow \mathbb{R}^n$ satisfies the following conditions:

2.A. The function $f(\cdot, \cdot, \cdot) : [t_0, \theta] \times \mathbb{R}^n \times \mathbb{R}^m \rightarrow \mathbb{R}^n$ is continuous.

2.B. For every bounded set $D \subset [t_0, \theta] \times \mathbb{R}^n$ there exist $\gamma_1 = \gamma_1(D) > 0$, $\gamma_2 = \gamma_2(D) > 0$ and $\gamma_3 = \gamma_3(D) > 0$ such that the inequality

$$\|f(t, x_1, u_1) - f(t, x_2, u_2)\| \leq [\gamma_1 + \gamma_2(\|u_1\| + \|u_2\|)] \|x_1 - x_2\| + \gamma_3 \|u_1 - u_2\|$$

is satisfied for every $(t, x_1, u_1) \in D \times \mathbb{R}^m$ and $(t, x_2, u_2) \in D \times \mathbb{R}^m$.

2.C. There exists $\kappa > 0$ such that the inequality

$$\|f(t, x, u)\| \leq \kappa (\|x\| + 1) (\|u\| + 1)$$

is held for every $(t, x, u) \in [t_0, \theta] \times \mathbb{R}^n \times \mathbb{R}^m$.

If the function $(t, x, u) \rightarrow f(t, x, u) : [t_0, \theta] \times \mathbb{R}^n \times \mathbb{R}^m \rightarrow \mathbb{R}^n$ is Lipschitz continuous with respect to (x, u) , then the conditions 2.B and 2.C are satisfied.

Let us define the trajectory of the system (2.1) generated by a control function $u_*(\cdot) \in L_2([t_0, \theta]; \mathbb{R}^m)$. An absolutely continuous function $x_*(\cdot) : [t_0, \theta] \rightarrow \mathbb{R}^n$ satisfying the equation $\dot{x}_*(t) = f(t, x_*(t), u_*(t))$ for almost all $t \in [t_0, \theta]$ and initial condition $x_*(t_0) = x_0$ is said to be a trajectory of the system (2.1) generated by the control function $u_*(\cdot) \in L_2([t_0, \theta]; \mathbb{R}^m)$. The sets of trajectories of the system (2.1) generated by all admissible control functions $u(\cdot) \in U_\varepsilon$, $u(\cdot) \in U_\varepsilon^\alpha$ and $u(\cdot) \in U_0^*$ are denoted by $X_\varepsilon(t_0, x_0)$, $X_\varepsilon^\alpha(t_0, x_0)$ and $X_0^*(t_0, x_0)$ respectively. It is obvious that the inclusions

$$X_\varepsilon^\alpha(t_0, x_0) \subset X_\varepsilon(t_0, x_0), \quad X_0^*(t_0, x_0) \subset X_\varepsilon(t_0, x_0)$$

are verified for every $\varepsilon \in [0, 1]$ and $\alpha > 0$.

For fixed $t \in [t_0, \theta]$ we set

$$X_\varepsilon(t; t_0, x_0) = \{x(t) \in \mathbb{R}^n : x(\cdot) \in X_\varepsilon(t_0, x_0)\}, \quad (2.3)$$

$$X_\varepsilon^\alpha(t; t_0, x_0) = \{x(t) \in \mathbb{R}^n : x(\cdot) \in X_\varepsilon^\alpha(t_0, x_0)\}, \quad (2.4)$$

$$X_0^*(t; t_0, x_0) = \{x(t) \in \mathbb{R}^n : x(\cdot) \in X_0^*(t_0, x_0)\}. \quad (2.5)$$

The sets $X_\varepsilon(t; t_0, x_0)$, $X_\varepsilon^\alpha(t; t_0, x_0)$ and $X_0^*(t; t_0, x_0)$ are called the attainable sets of the system (2.1) at the instant of time t , generated by all admissible control functions from the sets U_ε , U_ε^α and U_0^* respectively.

It is obvious that the attainable sets consist of points to which arrive the trajectories of the system (2.1) at the instant of time t .

By symbol $C([t_0, \theta]; \mathbb{R}^n)$ we denote the space of continuous functions $x(\cdot) : [t_0, \theta] \rightarrow \mathbb{R}^n$ with norm

$$\|x(\cdot)\|_C = \max \{\|x(t)\| : t \in [t_0, \theta]\},$$

$h_n(\cdot, \cdot)$ and $h_C(\cdot, \cdot)$ stand for the Hausdorff distance between the subsets of the spaces \mathbb{R}^n and $C([t_0, \theta]; \mathbb{R}^n)$ respectively.

Let us formulate the propositions which will be used in following arguments.

Proposition 2. *Each control function $u(\cdot) \in L_2([t_0, \theta]; \mathbb{R}^m)$ generates unique trajectory of the system (2.1).*

Denote

$$\alpha_* = \kappa \left[(\theta - t_0) + (\theta - t_0)^{1/2} c_* \right] \cdot \exp \kappa \left[(\theta - t_0) + c_* (\theta - t_0)^{1/2} \right] \quad (2.6)$$

where c_* is defined by (2.2).

The following proposition characterizes boundedness of the set of trajectories.

Proposition 3. *For every $\varepsilon \in [0, 1]$ and $x(\cdot) \in X_\varepsilon(t_0, x_0)$ the inequality $\|x(\cdot)\|_C \leq \alpha_*$ holds.*

P r o o f. Let us choose an arbitrary $\varepsilon > 0$ and $x(\cdot) \in X_\varepsilon(t_0, x_0)$, generated by the control function $u(\cdot) \in U_\varepsilon$. According to the Condition 2.C, inequality (2.2) and Cauchy–Schwarz inequality we have

$$\begin{aligned} \|x(t)\| &\leq \kappa \int_{t_0}^t (\|x(\tau)\| + 1) (\|u(\tau)\| + 1) d\tau \\ &\leq \kappa \int_{t_0}^t (\|u(\tau)\| + 1) \|x(\tau)\| d\tau + \kappa \left[(\theta - t_0) + (\theta - t_0)^{1/2} c_* \right] \end{aligned}$$

for every $t \in [t_0, \theta]$. Applying Bellman–Gronwall inequality and Cauchy–Schwarz inequality and taking into consideration (2.2) and (2.6) we conclude from the last inequality

$$\begin{aligned} \|x(t)\| &\leq \kappa \left[(\theta - t_0) + (\theta - t_0)^{1/2} c_* \right] \cdot \exp \left[\kappa \int_{t_0}^{\theta} (\|u(\tau)\| + 1) d\tau \right] \\ &\leq \kappa \left[(\theta - t_0) + (\theta - t_0)^{1/2} c_* \right] \cdot \exp \kappa \left[(\theta - t_0) + c_* (\theta - t_0)^{1/2} \right] = \alpha_* \end{aligned} \quad (2.7)$$

for every $t \in [t_0, \theta]$. The inequality (2.7) completes the proof. \square

Let

$$\psi(\delta) = \kappa(\alpha_* + 1) \left(\delta + c_* \delta^{1/2} \right), \quad \delta \geq 0. \quad (2.8)$$

It is obvious that $\psi(\delta) \rightarrow 0$ as $\delta \rightarrow 0^+$.

Proposition 4. For every $\varepsilon \in [0, 1]$, $x(\cdot) \in X_\varepsilon(t_0, x_0)$, $t_1 \in [t_0, \theta]$ and $t_2 \in [t_0, \theta]$ the inequality

$$\|x(t_1) - x(t_2)\| \leq \psi(|t_1 - t_2|)$$

is verified, and hence

$$h_n(X_\varepsilon(t_1; t_0, x_0), X_\varepsilon(t_2; t_0, x_0)) \leq \psi(|t_1 - t_2|)$$

where $\psi(\cdot)$ is defined by (2.8).

P r o o f. Without loss of generality let us assume that $t_2 > t_1$. Choose an arbitrary $\varepsilon > 0$ and $x(\cdot) \in X_\varepsilon(t_0, x_0)$, generated by the control function $u(\cdot) \in U_\varepsilon$. According to the Condition 2.C, Proposition 3, (2.2) and (2.8) we have

$$\begin{aligned} \|x(t_2) - x(t_1)\| &\leq \kappa \int_{t_1}^{t_2} (\|x(\tau)\| + 1)(\|u(\tau)\| + 1) d\tau \leq \kappa(\alpha_* + 1) \int_{t_1}^{t_2} (\|u(\tau)\| + 1) d\tau \\ &\leq \kappa(\alpha_* + 1) \left[(t_2 - t_1) + (t_2 - t_1)^{1/2} c_* \right] = \psi(|t_2 - t_1|). \end{aligned}$$

The proposition is proved. \square

Proposition 3, Proposition 4 and Arzela-Ascoli theorem (see, e.g., [10, p. 102]) imply the validity of the following theorem.

Theorem 1. For each $\varepsilon \in [0, 1]$ the set of trajectories $X_\varepsilon(t_0, x_0)$ of the system (2.1) is a precompact subset of the space $C([t_0, \theta]; \mathbb{R}^n)$.

Note that in general, the set of trajectories $X_\varepsilon(t_0, x_0)$ and $X_0^*(t_0, x_0)$ are not closed subsets of the space $C([t_0, \theta]; \mathbb{R}^n)$ (see, [3, 6]). Denote

$$\begin{aligned} B_n(\alpha_*) &= \{x \in \mathbb{R}^n : \|x\| \leq \alpha_*\}, \\ D_n(\alpha_*) &= \{(t, x) \in [t_0, \theta] \times \mathbb{R}^n : x \in B_n(\alpha_*)\}, \end{aligned}$$

where α_* is defined by equality (2.6).

Here and henceforth we will have in mind the cylinder $D_n(\alpha_*)$ as the set D in Condition 2.B.

3. Properties of the set of trajectories

Denote

$$\beta_* = \gamma_1(\theta - t_0) + 2\gamma_2 c_*(\theta - t_0)^{1/2}, \quad (3.1)$$

$$g_* = \gamma_3 c_*(\theta - t_0)^{1/2} \cdot \exp(\beta_*), \quad (3.2)$$

$$B_C(1) = \{x(\cdot) \in C([t_0, \theta]; \mathbb{R}^n) : \|x(\cdot)\|_C \leq 1\}, \quad (3.3)$$

where c_* is defined in (2.2).

Proposition 5. *For every $\varepsilon \in [0, 1]$ the inequality*

$$h_C(X_\varepsilon(t_0, x_0), X_0(t_0, x_0)) \leq g_* \left(1 - \frac{1}{\sqrt{1 + \varepsilon}}\right)$$

holds.

P r o o f. Let us choose an arbitrary $x(\cdot) \in X_\varepsilon(t_0, x_0)$ generated by the control function $u(\cdot) \in U_\varepsilon$. Define new control function $u_0(\cdot) : [t_0, \theta] \rightarrow \mathbb{R}^m$, setting

$$u_0(t) = \frac{1}{\sqrt{1 + \varepsilon}} u(t), \quad t \in [t_0, \theta]. \quad (3.4)$$

The equality (3.4) yields that $u_0(\cdot) \in U_0$. Now, from (2.2), (3.4) and Cauchy-Schwarz inequality it follows that

$$\|u(\cdot) - u_0(\cdot)\|_1 = \int_{t_0}^\theta \left(1 - \frac{1}{\sqrt{1 + \varepsilon}}\right) \|u(\tau)\| d\tau \leq c_*(\theta - t_0)^{1/2} \left(1 - \frac{1}{\sqrt{1 + \varepsilon}}\right). \quad (3.5)$$

Let $x_0(\cdot) : [t_0, \theta] \rightarrow \mathbb{R}^n$ be the trajectory of the system (2.1) generated by the control function $u_0(\cdot) \in U_0$. Then $x_0(\cdot) \in X_0(t_0, x_0)$. From Condition 2.B, (2.1) and (3.5) it follows that

$$\begin{aligned} \|x(t) - x_0(t)\| &\leq \int_{t_0}^t [\gamma_1 + \gamma_2(\|u(\tau)\| + \|u_0(\tau)\|)] \|x(\tau) - x_0(\tau)\| d\tau \\ &\quad + \gamma_3 c_*(\theta - t_0)^{1/2} \left(1 - \frac{1}{\sqrt{1 + \varepsilon}}\right) \end{aligned} \quad (3.6)$$

for every $t \in [t_0, \theta]$.

Taking into consideration the inequality (2.2), Gronwall–Bellman inequality and Cauchy–Schwarz inequality, from (3.1), (3.2) and (3.6) we obtain

$$\begin{aligned} \|x(t) - x_0(t)\| &\leq \gamma_3 c_*(\theta - t_0)^{1/2} \left(1 - \frac{1}{\sqrt{1 + \varepsilon}}\right) \cdot \exp \left[\int_{t_0}^\theta [\gamma_1 + \gamma_2(\|u(\tau)\| + \|u_0(\tau)\|)] d\tau \right] \\ &\leq \gamma_3 c_*(\theta - t_0)^{1/2} \left(1 - \frac{1}{\sqrt{1 + \varepsilon}}\right) \cdot \exp(\beta_*) = g_* \left(1 - \frac{1}{\sqrt{1 + \varepsilon}}\right) \end{aligned}$$

for every $t \in [t_0, \theta]$, and hence

$$\|x(\cdot) - x_0(\cdot)\|_C \leq g_* \left(1 - \frac{1}{\sqrt{1 + \varepsilon}}\right).$$

Since $x(\cdot) \in X_\varepsilon(t_0, x_0)$ is an arbitrarily chosen trajectory, $x_0(\cdot) \in X_0(t_0, x_0)$, then the last inequality implies that

$$X_\varepsilon(t_0, x_0) \subset X_0(t_0, x_0) + g_* \left(1 - \frac{1}{\sqrt{1 + \varepsilon}}\right) B_C(1) \quad (3.7)$$

where $B_C(1)$ is defined by (3.3). From inclusion $X_0(t_0, x_0) \subset X_\varepsilon(t_0, x_0)$ and (3.7) we obtain the proof of the proposition. \square

From Proposition 5 it follows the validity of the following corollaries.

Corollary 1. $h_C(X_\varepsilon(t_0, x_0), X_0(t_0, x_0)) \rightarrow 0$ as $\varepsilon \rightarrow 0^+$.

Corollary 2. For every $\varepsilon \in [0, 1]$ and $t \in [t_0, \theta]$ the inequality

$$h_n(X_\varepsilon(t; t_0, x_0), X_0(t; t_0, x_0)) \leq g_* \left(1 - \frac{1}{\sqrt{1 + \varepsilon}} \right)$$

is verified where the sets $X_\varepsilon(t; t_0, x_0)$, $\varepsilon \in [0, 1]$, are defined by (2.3).

Denote

$$r_* = 2\gamma_3 c_*^2 \cdot \exp(\beta_*) \quad (3.8)$$

where β_* is defined by (3.1).

Proposition 6. For every $\varepsilon \in [0, 1]$ and $\alpha > 0$ the inequality

$$h_C(X_\varepsilon(t_0, x_0), X_\varepsilon^\alpha(t_0, x_0)) \leq \frac{r_*}{\alpha}$$

is satisfied where r_* is defined by (3.8).

P r o o f. Let us choose an arbitrary $\varepsilon \in [0, 1]$ and $y(\cdot) \in X_\varepsilon(t_0, x_0)$ generated by the control function $v(\cdot) \in U_\varepsilon$. Define new control function $v_*(\cdot) : [t_0, \theta] \rightarrow \mathbb{R}^m$, setting

$$v_*(t) = \begin{cases} v(t) & \text{if } \|v(t)\| \leq \alpha, \\ \frac{v(t)}{\|v(t)\|} \cdot \alpha & \text{if } \|v(t)\| > \alpha. \end{cases} \quad (3.9)$$

Let

$$A_* = \{t \in [t_0, \theta] : \|v(t)\| > \alpha\}.$$

Then from (2.2) we have

$$\alpha^2 \mu(A_*) \leq \int_{A_*} \|v(\tau)\|^2 d\tau \leq \int_{t_0}^{\theta} \|v(\tau)\|^2 d\tau \leq c_*^2,$$

and hence

$$\mu(A_*) \leq \frac{c_*^2}{\alpha^2} \quad (3.10)$$

where $\mu(A_*)$ stands for the Lebesgue measure of the set A_* .

Since $v(\cdot) \in U_\varepsilon$ and $\|v(\tau)\| > \alpha$ for every $\tau \in A_*$, then (3.9) implies that

$$\begin{aligned} & \int_{t_0}^{\theta} \langle B(\tau)v_*(\tau), v_*(\tau) \rangle d\tau \\ &= \int_{[t_0, \theta] \setminus A_*} \langle B(\tau)v(\tau), v(\tau) \rangle d\tau + \int_{A_*} \langle B(\tau)v(\tau), v(\tau) \rangle \cdot \frac{\alpha^2}{\|v(\tau)\|^2} d\tau \\ &\leq \int_{[t_0, \theta] \setminus A_*} \langle B(\tau)v(\tau), v(\tau) \rangle d\tau + \int_{A_*} \langle B(\tau)v(\tau), v(\tau) \rangle d\tau \\ &= \int_{t_0}^{\theta} \langle B(\tau)v(\tau), v(\tau) \rangle d\tau \leq 1 + \varepsilon. \end{aligned} \quad (3.11)$$

Now, (3.9) and (3.11) yield that $v_*(\cdot) \in U_\varepsilon^\alpha$. Let $y_*(\cdot) : [t_0, \theta] \rightarrow \mathbb{R}^n$ be the trajectory of the system (2.1) generated by the control function $v_*(\cdot) \in U_\varepsilon^\alpha$. Then $y_*(\cdot) \in X_\varepsilon^\alpha(t_0, x_0)$. Now the condition 2.B, inclusions $v(\cdot) \in U_\varepsilon$, $v_*(\cdot) \in U_\varepsilon^\alpha$, (2.2), (3.9) and (3.10) imply that

$$\begin{aligned} \|y(t) - y_*(t)\| &\leq \int_{t_0}^t [\gamma_1 + \gamma_2(\|v(\tau)\| + \|v_*(\tau)\|)] \|y(\tau) - y_*(\tau)\| d\tau + \gamma_3 \int_{A_*} \|v(\tau) - v_*(\tau)\| d\tau \\ &\leq \int_{t_0}^t [\gamma_1 + \gamma_2(\|v(\tau)\| + \|v_*(\tau)\|)] \|y(\tau) - y_*(\tau)\| d\tau + \gamma_3 \cdot [\mu(A_*)]^{1/2} [\|v(\cdot)\|_2 + \|v_*(\cdot)\|_2] \\ &\leq \int_{t_0}^t [\gamma_1 + \gamma_2(\|v(\tau)\| + \|v_*(\tau)\|)] \|y(\tau) - y_*(\tau)\| d\tau + \frac{2\gamma_3 c_*^2}{\alpha} \end{aligned}$$

for every $t \in [t_0, \theta]$. The last inequality, the inclusions $v(\cdot) \in U_\varepsilon$, $v_*(\cdot) \in U_\varepsilon^\alpha$, Bellman–Gronwall inequality and (3.8) yield

$$\|y(t) - y_*(t)\| \leq \frac{2\gamma_3 c_*^2}{\alpha} \cdot \exp\left(\int_{t_0}^\theta [\gamma_1 + \gamma_2(\|v(\tau)\| + \|v_*(\tau)\|)] d\tau\right) \leq \frac{2\gamma_3 c_*^2}{\alpha} \cdot \exp(\beta_*) = \frac{r_*}{\alpha}$$

for every $t \in [t_0, \theta]$, and hence

$$\|y(\cdot) - y_*(\cdot)\|_C \leq \frac{r_*}{\alpha}. \quad (3.12)$$

Since $y(\cdot) \in X_\varepsilon(t_0, x_0)$ is an arbitrarily chosen trajectory, $y_*(\cdot) \in X_\varepsilon^\alpha(t_0, x_0)$, then from (3.12) it follows that

$$X_\varepsilon(t_0, x_0) \subset X_\varepsilon^\alpha(t_0, x_0) + \frac{r_*}{\alpha} \cdot B_C(1), \quad (3.13)$$

where the set $B_C(1)$ is defined by (3.3). Taking into consideration that $X_\varepsilon^\alpha(t_0, x_0) \subset X_\varepsilon(t_0, x_0)$, we obtain from (3.13) the proof of the proposition. \square

Corollary 3. $h_C(X_\varepsilon(t_0, x_0), X_\varepsilon^\alpha(t_0, x_0)) \rightarrow 0$ as $\alpha \rightarrow +\infty$ uniformly with respect to the $\varepsilon \in [0, 1]$.

From Propositions 5 and 6 it follows the validity of the following theorem.

Theorem 2. For every $\varepsilon \in [0, 1]$ and $\alpha > 0$ the inequality

$$h_C(X_0(t_0, x_0), X_\varepsilon^\alpha(t_0, x_0)) \leq g_* \left(1 - \frac{1}{\sqrt{1+\varepsilon}}\right) + \frac{r_*}{\alpha}$$

is satisfied where g_* and r_* are defined by (3.2) and (3.8) respectively.

Corollary 4. For every $\varepsilon \in [0, 1]$, $\alpha > 0$ and $t \in [t_0, \theta]$ the inequality

$$h_n(X_0(t; t_0, x_0), X_\varepsilon^\alpha(t; t_0, x_0)) \leq g_* \left(1 - \frac{1}{\sqrt{1+\varepsilon}}\right) + \frac{r_*}{\alpha}$$

is satisfied where $X_\varepsilon^\alpha(t; t_0, x_0)$ is defined by (2.4).

4. Robustness of the trajectories

Let us discuss the robustness of the trajectories with respect to the fast consumption of the remaining control resource.

Proposition 7. Let $\nu > 0$ be a given number, $Q_* \subset [a, b]$ be Lebesgue measurable set, $z(\cdot) \in X_0(t_0, x_0)$ be a trajectory of the system (2.1) generated by the control function $w(\cdot) \in U_0$,

$$\int_{t_0}^{\theta} \langle B(\tau)w(\tau), w(\tau) \rangle d\tau = \sigma_* < 1,$$

the control function $w_*(\cdot) \in L_2([t_0, \theta]; \mathbb{R}^m)$ be such that

$$\int_{t_0}^{\theta} \langle B(\tau)w_*(\tau), w_*(\tau) \rangle d\tau = 1, \quad w_*(t) = w(t), \quad t \in [t_0, \theta] \setminus Q_*,$$

and $z_*(\cdot)$ be the trajectory of the system (2.1) generated by the control function $w_*(\cdot)$. If

$$\mu(Q_*) \leq \left[\frac{\nu}{2c_*\gamma_3 \exp(\beta_*)} \right]^2, \quad (4.1)$$

then

$$\|z(\cdot) - z_*(\cdot)\|_C \leq \nu$$

where c_* is defined by (2.2), β_* is defined by (3.1).

P r o o f. Let us underline that the equality

$$\int_{t_0}^{\theta} \langle B(\tau)w_*(\tau), w_*(\tau) \rangle d\tau = 1$$

implies that $w_*(\cdot) \in U_0^*$ and hence $z_*(\cdot) \in X_0^*(t_0, x_0)$. From Condition 2.B, inclusions $w(\cdot) \in U_0$, $w_*(\cdot) \in U_0^*$, (2.2) and definition of the control function $w_*(\cdot)$ it follows that

$$\begin{aligned} \|z(t) - z_*(t)\| &\leq \int_{t_0}^t [\gamma_1 + \gamma_2(\|w(\tau)\| + \|w_*(\tau)\|)] \|z(\tau) - z_*(\tau)\| d\tau + \gamma_3 \int_{Q_*} \|w(\tau) - w_*(\tau)\| d\tau \\ &\leq \int_{t_0}^t [\gamma_1 + \gamma_2(\|w(\tau)\| + \|w_*(\tau)\|)] \|z(\tau) - z_*(\tau)\| d\tau + \gamma_3 \cdot [\mu(Q_*)]^{1/2} [\|w(\cdot)\|_2 + \|w_*(\cdot)\|_2] \\ &\leq \int_{t_0}^t [\gamma_1 + \gamma_2(\|w(\tau)\| + \|w_*(\tau)\|)] \|z(\tau) - z_*(\tau)\| d\tau + 2\gamma_3 c_* \cdot [\mu(Q_*)]^{1/2} \end{aligned}$$

for every $t \in [t_0, \theta]$. The last inequality, the inclusions $w(\cdot) \in U_0$, $w_*(\cdot) \in U_0^*$, Bellman–Gronwall inequality, (3.1) and (4.1) imply

$$\begin{aligned} \|z(t) - z_*(t)\| &\leq 2\gamma_3 c_* [\mu(Q_*)]^{1/2} \cdot \exp \left(\int_{t_0}^{\theta} [\gamma_1 + \gamma_2(\|w(\tau)\| + \|w_*(\tau)\|)] d\tau \right) \\ &\leq 2\gamma_3 c_* [\mu(Q_*)]^{1/2} \cdot \exp(\beta_*) \leq \nu \end{aligned}$$

for every $t \in [t_0, \theta]$, and consequently $\|z(\cdot) - z_*(\cdot)\|_C \leq \nu$.

The proof is completed. □

Theorem 3. *The equality*

$$h_C(X_0(t_0, x_0), X_0^*(t_0, x_0)) = 0$$

holds.

P r o o f. Let $\nu > 0$ be an arbitrary fixed number and let us choose an arbitrary trajectory $x(\cdot) \in X_0(t_0, x_0)$ of the system (2.1) generated by the control function $u(\cdot) \in U_0$. Assume that

$$\int_{t_0}^{\theta} \langle B(\tau)u(\tau), u(\tau) \rangle d\tau = \sigma_* < 1.$$

Let $Q_* \subset [t_0, \theta]$ be such that

$$\mu(Q_*) \leq \left[\frac{\nu}{2c_*\gamma/3 \exp(\beta_*)} \right]^2, \quad (4.2)$$

where c_* is defined by (2.2), β_* is defined by (3.1) and let

$$\int_{[t_0, \theta] \setminus Q_*} \langle B(\tau)u(\tau), u(\tau) \rangle d\tau = \sigma_1, \quad (4.3)$$

$$B_* = \int_{Q_*} B(\tau) d\tau. \quad (4.4)$$

It is obvious that B_* is positive definite $m \times m$ matrix and $\sigma_1 \leq \sigma_* < 1$.

Define new control function $v_0(\cdot) : [t_0, \theta] \rightarrow \mathbb{R}^m$, setting

$$v_0(t) = \begin{cases} u(t) & \text{if } t \in [t_0, \theta] \setminus Q_*, \\ u_0 & \text{if } t \in Q_*, \end{cases} \quad (4.5)$$

where $u_0 \in \mathbb{R}^m$ is such that

$$\langle B_*u_0, u_0 \rangle = 1 - \sigma_1. \quad (4.6)$$

From (4.3), (4.4), (4.5) and (4.6) it follows that

$$\begin{aligned} \int_{t_0}^{\theta} \langle B(\tau)v_0(\tau), v_0(\tau) \rangle d\tau &= \int_{[t_0, \theta] \setminus Q_*} \langle B(\tau)u(\tau), u(\tau) \rangle d\tau + \int_{Q_*} \langle B(\tau)u_0, u_0 \rangle d\tau \\ &= \sigma_1 + \left\langle \left(\int_{Q_*} B(\tau) d\tau \right) u_0, u_0 \right\rangle = \sigma_1 + \langle B_*u_0, u_0 \rangle = \sigma_1 + 1 - \sigma_1 = 1, \end{aligned}$$

and hence $v_0(\cdot) \in U_0^*$. Let $x_0(\cdot)$ be the trajectory of the system (2.1) generated by the control function $v_0(\cdot) \in U_0^*$. Then $x_0(\cdot) \in X_0^*(t_0, x_0)$ and from (4.2) and Proposition 7 we obtain

$$\|x(\cdot) - x_0(\cdot)\|_C \leq \nu.$$

Since $x(\cdot) \in X_0(t_0, x_0)$ is an arbitrarily chosen trajectory, $x_0(\cdot) \in X_0^*(t_0, x_0)$, then the last inequality implies that

$$X_0(t_0, x_0) \subset X_0^*(t_0, x_0) + \nu \cdot B_C(1) \quad (4.7)$$

where $B_C(1)$ is defined by (3.3). Taking into consideration that $X_0^*(t_0, x_0) \subset X_0(t_0, x_0)$, from (4.7) we obtain that

$$h_C(X_0^*(t_0, x_0), X_0(t_0, x_0)) \leq \nu. \quad (4.8)$$

Since $\nu > 0$ is an arbitrarily fixed number, then (4.8) yields the proof of the theorem. \square

From Theorem 3 we obtain the validity of the following corollaries.

Corollary 5. *The equality*

$$\text{cl}(X_0(t_0, x_0)) = \text{cl}(X_0^*(t_0, x_0))$$

is verified where cl denotes the closure of a set.

The Corollary 5 means that every trajectory $x(\cdot) \in X_0(t_0, x_0)$ of the system (2.1) can be approximated by the trajectory which is generated by full consumption of the control resource.

Corollary 6. For every $t \in [t_0, \theta]$ the equality

$$\text{cl}(X_0(t; t_0, x_0)) = \text{cl}(X_0^*(t; t_0, x_0))$$

is satisfied where $X_0(t; t_0, x_0)$ and $X_0^*(t; t_0, x_0)$ are defined by (2.3) and (2.5) respectively.

From Theorems 2 and 3 we obtain the validity of the following theorem.

Theorem 4. For every $\varepsilon \in [0, 1]$ and $\alpha > 0$ the inequality

$$h_C(X_0^*(t_0, x_0), X_\varepsilon^\alpha(t_0, x_0)) \leq g_* \left(1 - \frac{1}{\sqrt{1 + \varepsilon}} \right) + \frac{r_*}{\alpha}$$

is satisfied where g_* and r_* are defined by (3.2) and (3.8) respectively.

5. Conclusion

The results asserting that a small perturbations in the quadratic integral constraints inspire a small deviation on the set of trajectories can be applied in mathematical modelling of the control systems where the total control resource is measured with small errors. According to the obtained results, it is possible to introduce a norm type geometric constraint along with quadratic type integral constraint where upper bound of the norm type geometric constraint is sufficiently large. Since the integrally constrained control functions are not geometrically constrained, this fact simplifies the structure of the set of control functions and allows to avoid geometrical unboundedness of the admissible control functions.

Robustness of the trajectories with respect to the fast and full consumption implies that it is reasonable to spend the control resource in economical mode, i.e. it is advisable to consume the control resource on the domains with sufficiently small Lebesgue measures in small portions. This yields that if you have a superfluous control resource and you want to get rid of this resource, then by spending all of the resource on the domain with sufficiently small Lebesgue measure, you will get a small deviation from the original system's trajectory.

REFERENCES

1. Beletskii V.V. *Notes on the Motion of Celestial Bodies*. Moscow: Nauka, 1972. 360 p.
2. Conti R. *Problemi di Controllo e di Controllo Ottimale*. Torino: UTET, 1974. 239 p. (in Italian)
3. Filippov A.F. *Differential Equations with Discontinuous Right-Hand Sides*. Dordrecht: Kluwer, 1988. 304 p.
4. Gusev M.I., Zykov I.V. On the geometry of the reachable sets of control systems with isoperimetric constraints. *Tr. Inst. Mat. Mekh. UrO RAN*, 2018. Vol. 24, No. 1. P. 63–75. DOI: [10.21538/0134-4889-2018-24-1-63-75](https://doi.org/10.21538/0134-4889-2018-24-1-63-75) (in Russian)
5. Guseinov K.G., Ozer O., Akyar E., Ushakov V.N. The approximation of reachable sets of control systems with integral constraint on controls. *Nonlin. Dif. Equat. Appl. (NoDEA)*, 2007. Vol. 14, No. 1-2. P. 57–73. DOI: [10.1007/s00030-006-4036-6](https://doi.org/10.1007/s00030-006-4036-6)
6. Guseinov Kh.G., Nazlipinar A.S. On the continuity properties of the attainable sets of nonlinear control systems with integral constraint on controls. *Abstr. Appl. Anal.*, 2008. Art ID 295817, 14 pp. DOI: [10.1155/2008/295817](https://doi.org/10.1155/2008/295817)
7. Huseyin N., Huseyin A., Guseinov Kh.G. Approximations of the set of trajectories and integral funnel of the non-linear control systems with L_p norm constraints on the control functions. *IMA J. Math. Control Inform.*, 2022. Vol. 39, No. 4. P. 1213–1231. DOI: [10.1093/imamci/dnac028](https://doi.org/10.1093/imamci/dnac028)

8. Huseyin A., Huseyin N., Guseinov Kh. G. Approximations of the images and integral funnels of the L_p balls under a Urysohn-type integral operator. *Funktsionalnyi Analiz i ego Prilozheniya*, 2022. Vol. 56, No. 4. P. 43–58. DOI: [10.4213/faa3974](https://doi.org/10.4213/faa3974)
9. Ibragimov G., Ferrara M., Kuchkarov A., Pansera B. A. Simple motion evasion differential game of many pursuers and evaders with integral constraints. *Dynamic Games Appl.*, 2018. Vol. 8, No. 2. P. 352–378. DOI: [10.1007/s13235-017-0226-6](https://doi.org/10.1007/s13235-017-0226-6)
10. Kolmogorov A. N., Fomin S. V. *Introductory Real Analysis*. New York: Dover Publications, Inc., 1975. 403 p.
11. Kostousova E. K. On the polyhedral estimation of reachable sets in the "extended" space for discrete-time systems with uncertain matrices and integral constraints. *Tr. Inst. Mat. Mekh. UrO RAN*, 2020. Vol. 26, No. 1. P. 141–155. DOI: [10.21538/0134-4889-2020-26-1-141-155](https://doi.org/10.21538/0134-4889-2020-26-1-141-155) (in Russian)
12. Krasovskii N. N. *Theory of Control of Motion: Linear Systems*. Moscow: Nauka, 1968. 475 p. (in Russian)
13. Motta M., Sartori C. Minimum time with bounded energy, minimum energy with bounded time. *SIAM J. Contr. Optimiz.*, 2003. Vol. 42, No. 3. P. 789–809. DOI: [10.1137/S0363012902385284](https://doi.org/10.1137/S0363012902385284)
14. Rouse R., Garoche P.-L., Henrion D. Parabolic set simulation for reachability analysis of linear time-invariant systems with integral quadratic constraint. *European J. Contr.*, 2021. Vol. 58. P. 152–167. DOI: [10.1016/j.ejcon.2020.08.002](https://doi.org/10.1016/j.ejcon.2020.08.002)
15. Subbotin A. I., Ushakov V. N. Alternative for an encounter-evasion differential game with integral constraints on the players controls. *J. Appl. Math. Mech.*, 1975. Vol. 39, No. 3. P. 387–396. DOI: [10.1016/0021-8928\(75\)90001-5](https://doi.org/10.1016/0021-8928(75)90001-5)
16. Subbotina N. N., Subbotin A. I. Alternative for the encounter-evasion differential game with constraints on the momenta of the players' controls. *J. Appl. Math. Mech.*, 1975. Vol. 39, No. 3. P. 397–406. DOI: [10.1016/0021-8928\(75\)90002-7](https://doi.org/10.1016/0021-8928(75)90002-7)

INEQUALITIES FOR A CLASS OF MEROMORPHIC FUNCTIONS WHOSE ZEROS ARE WITHIN OR OUTSIDE A GIVEN DISK¹

Mohd Yousf Mir[†], Shah Lubna Wali^{††}, Wali Mohammad Shah^{†††}

Department of Mathematics, Central University of Kashmir,
Ganderbal-191201, India

[†]myousf@cukashmir.ac.in ^{††}shahlw@yahoo.co.in ^{†††}wali@cukashmir.ac.in

Abstract: In this paper, we consider a class of meromorphic functions $r(z)$ having an s -fold zero at the origin and establish some inequalities of Bernstein and Turán type for the modulus of the derivative of rational functions in the sup-norm on the disk in the complex plane. These results produce some sharper inequalities while taking into account the placement of zeros of the underlying rational function. Moreover, many inequalities for polynomials and polar derivatives follow as special cases. In particular, our results generalize as well as refine a result due Dewan et al. [6].

Keywords: Polynomial, Rational function, s -fold zeros, Bernstein inequality.

1. Introduction

Let \mathcal{P}_n denote the class of all complex polynomials

$$p(z) := \sum_{j=0}^n a_j z^j$$

of degree at most n and $p'(z)$ denote the derivative of $p(z)$. Let D_k^- denote the region inside $T_k := \{z : |z| = k\}$ and D_k^+ denote the region outside T_k . For $\alpha_j \in \mathbb{C}$, we write

$$w(z) := \prod_{j=1}^n (z - \alpha_j); \quad B(z) := \prod_{j=1}^n \left(\frac{1 - \overline{\alpha_j} z}{z - \alpha_j} \right)$$

and

$$\mathcal{R}_n = \mathcal{R}_n(\alpha_1, \alpha_2, \dots, \alpha_n) := \left\{ \frac{p(z)}{w(z)} : p \in \mathcal{P}_n \right\},$$

the set of rational functions with poles $\alpha_1, \alpha_2, \dots, \alpha_n$, such that $\alpha_j \in D_1^+$ and with finite limit at infinity. A famous result due to Bernstein states that:

Theorem 1 [5]. *If $p \in \mathcal{P}_n$, then for any $z \in \mathbb{C}$*

$$\max_{z \in T_1} |p'(z)| \leq n \max_{z \in T_1} |p(z)|.$$

¹The first author is highly thankful to the funding agency DST-INSPIRE for their financial support.

If $p(z) \neq 0$ for $z \in D_1^-$ then it was conjectured by Erdős and latter proved by Lax [9] that

$$\max_{z \in T_1} |p'(z)| \leq \frac{n}{2} \max_{z \in T_1} |p(z)|,$$

where as, if $p(z) \neq 0$ for $z \in D_1^+$, then Turán [11] proved:

$$\max_{z \in T_1} |p'(z)| \geq \frac{n}{2} \max_{z \in T_1} |p(z)|.$$

Li, Mohapatra and Rodriguez [10] obtained Bernstein-type inequalities for rational functions $r \in \mathcal{R}_n$ with prescribed poles $\alpha_1, \alpha_2, \dots, \alpha_n$ replacing z^n by Blasheke product $B(z)$. Among other things they proved the following results for rational functions with prescribed poles.

Theorem 2. *If $r \in \mathcal{R}_n$ has n zeros all lie in $T_1 \cup D_1^+$, then for $z \in T_1$, we have*

$$|r'(z)| \leq \frac{1}{2} |B'(z)| |r(z)|.$$

The result is sharp and equality holds for $r(z) = aB(z) + b$, with $|a| = |b| = 1$.

As a refinement of Theorem 2, Aziz and Shah [2] proved the following:

Theorem 3. *Let $r \in \mathcal{R}_n$ be such that all the zeros of $r(z)$ lie in $T_1 \cup D_1^+$. If t_1, t_2, \dots, t_n are the zeros of $B(z) + \lambda$ and s_1, s_2, \dots, s_n are the zeros of $B(z) - \lambda, \lambda \in T_1$, then for $z \in T_1$*

$$|r'(z)| \leq \frac{|B'(z)|}{2} \left\{ \left(\max_{1 \leq j \leq n} |r(t_j)| \right)^2 + \left(\max_{1 \leq j \leq n} |r(s_j)| \right)^2 \right\}^{1/2}. \tag{1.1}$$

In this paper we prove some results which infact strengthen certain known inequalities for rational functions with prescribed poles and inturn produce refinements of some known polynomial inequalities. We first prove the following generalization as well as a refinement of a result due to Wali and Shah [12].

2. Main results

Theorem 4. *Let*

$$r(z) = \frac{p(z)}{w(z)} \in \mathcal{R}_n,$$

where

$$p(z) = z^s \left(a_0 + \sum_{j=1}^{m-s} a_j z^j \right)$$

is a polynomial of degree m , having all zeros in $T_k \cup D_k^+$, $k \geq 1$ except an s -fold zero at the origin. If t_1, t_2, \dots, t_n are the zeros of $B(z) + \lambda$ and s_1, s_2, \dots, s_n are the zeros of $B(z) - \lambda, \lambda \in T_1$, then for $z \in T_1$

$$|r'(z)| \leq \frac{|B'(z)|}{2} \left\{ \left(\max_{1 \leq j \leq n} |r(t_j)| \right)^2 + \left(\max_{1 \leq j \leq n} |r(s_j)| \right)^2 - 4 \left[\left(\frac{k}{1+k} \left(\frac{|a_0| - k^{m-s} |a_{m-s}|}{|a_0| + k^{m-s} |a_{m-s}|} \right) - \frac{sk}{1+k} - \frac{2m - n(1+k)}{2(1+k)} \right) \frac{|r(z)|^2}{|B'(z)|} \right] \right\}^{1/2}.$$

If we take $k = 1$ and $m = n$, in Theorem 4, we get the following:

Corollary 1. *Let*

$$r(z) = \frac{p(z)}{w(z)} \in \mathcal{R}_n,$$

where

$$p(z) = z^s \left(a_0 + \sum_{j=1}^{n-s} a_j z^j \right)$$

is a polynomial of degree n , having all zeros in $T_1 \cup D_1^+$ except a zero of multiplicity s at origin. If t_1, t_2, \dots, t_n are the zeros of $B(z) + \lambda$ and s_1, s_2, \dots, s_n are the zeros of $B(z) - \lambda$, $\lambda \in T_1$, then for $z \in T_1$

$$|r'(z)| \leq \frac{|B'(z)|}{2} \left\{ \left(\max_{1 \leq j \leq n} |r(t_j)| \right)^2 + \left(\max_{1 \leq j \leq n} |r(s_j)| \right)^2 - 2 \left[\left(\frac{|a_0| - |a_{n-s}|}{|a_0| + |a_{n-s}|} \right) \frac{|r(z)|^2}{|B'(z)|} - s \right] \right\}^{1/2}. \quad (2.1)$$

On comparing inequalities (1.1) and (2.1) and noting that $|a_0| \geq |a_{n-s}|$, it is easy to see that for $s = 0$, Corollary 1 is an improvement of Theorem 3 which is a result due to Aziz and Shah [2].

Remark 1. For $s = 0, k = 1$ and $m = n$, Theorem 4 reduces to a result due to Wali and Shah [12, Theorem 1].

It is to be noted that in the paper of Wali and Shah [12] an advanced tool (Osserman's lemma) has been used for its proof. However, we here use a simple application of mathematical induction to prove a more general result from which the result of Wali and Shah follows as special case.

If we take $s = 0, m = n$ in Theorem 4, we have the following:

Corollary 2. *Let*

$$r(z) = \frac{p(z)}{w(z)} \in \mathcal{R}_n,$$

where

$$p(z) = \left(a_0 + \sum_{j=1}^n a_j z^j \right)$$

is a polynomial of degree n , having all zeros in $T_k \cup D_k^+$, $k \geq 1$. If t_1, t_2, \dots, t_n are the zeros of $B(z) + \lambda$ and s_1, s_2, \dots, s_n are the zeros of $B(z) - \lambda$, $\lambda \in T_1$, then for $z \in T_1$

$$|r'(z)| \leq \frac{|B'(z)|}{2} \left\{ \left(\max_{1 \leq j \leq n} |r(t_j)| \right)^2 + \left(\max_{1 \leq j \leq n} |r(s_j)| \right)^2 - 4 \left[\frac{n(k-1)}{2(k+1)} + \frac{k}{k+1} \left(\frac{|a_0| - k^n |a_n|}{|a_0| + k^n |a_n|} \right) \frac{|r(z)|^2}{|B'(z)|} \right] \right\}^{1/2}.$$

If we consider that $r(z)$ has a pole of order n at $z = \alpha$, then

$$r(z) = \frac{p(z)}{(z - \alpha)^n},$$

where $p(z)$ is a polynomial of degree m . Therefore, we have

$$r'(z) = \left(\frac{p(z)}{(z - \alpha)^n} \right)' = -\frac{(n - m)p(z) + D_\alpha p(z)}{(z - \alpha)^{n+1}},$$

where for any $\alpha \in \mathbb{C}$, $D_\alpha p(z)$ denotes the polar derivative of the polynomial $p(z)$. Also

$$B(z) = \left(\frac{1 - \bar{\alpha}z}{z - \alpha} \right)^n = \frac{w^*(z)}{w(z)},$$

with $B(z) \rightarrow z^n$ as $\alpha \rightarrow \infty$, and

$$B'(z) = \frac{n(|\alpha|^2 - 1)}{(z - \alpha)^2} \left(\frac{1 - \bar{\alpha}z}{z - \alpha} \right)^{n-1}.$$

Further for $z \in T_1$,

$$|B'(z)| = \frac{n(|\alpha|^2 - 1)}{|z - \alpha|^2}.$$

Using these observations with $m = n$ in Theorem 4 and letting $|\alpha| \rightarrow \infty$, we get the following:

Corollary 3. *Let $p \in \mathcal{P}_n$ be such that all the zeros of*

$$p(z) = z^s \left(a_0 + \sum_{j=1}^{n-s} a_j z^j \right)$$

lie in $T_k \cup D_k^+$ except an s -fold zero at the origin. If t_1, t_2, \dots, t_n are the zeros of $z^n + \lambda$ and s_1, s_2, \dots, s_n are the zeros of $z^n - \lambda, \lambda \in T_1$, then for $z \in T_1$

$$|p'(z)| \leq \frac{n}{2} \left\{ \left(\max_{1 \leq j \leq n} |p(t_j)| \right)^2 + \left(\max_{1 \leq j \leq n} |p(s_j)| \right)^2 - 4 \left[\frac{k}{1+k} \left(\frac{|a_0| - k^{n-s}|a_{n-s}|}{|a_0| + k^{n-s}|a_{n-s}|} \right) - \frac{sk}{1+k} - \frac{n(1-k)}{2(1+k)} \right] \frac{|p(z)|^2}{n} \right\}^{1/2}.$$

By taking $k = 1$ in Corollary 3, we get the following:

Corollary 4. *Let $p \in \mathcal{P}_n$ be such that all the zeros of*

$$p(z) = z^s \left(a_0 + \sum_{j=1}^{n-s} a_j z^j \right)$$

lie in $T_1 \cup D_1^+$ except an s -fold zero at the origin. If t_1, t_2, \dots, t_n are the zeros of $z^n + \lambda$ and s_1, s_2, \dots, s_n are the zeros of $z^n - \lambda, \lambda \in T_1$, then for $z \in T_1$

$$|r'(z)| \leq \frac{|B'(z)|}{2} \left\{ \left(\max_{1 \leq j \leq n} |p(t_j)| \right)^2 + \left(\max_{1 \leq j \leq n} |p(s_j)| \right)^2 - 2 \left[\left(\frac{|a_0| - |a_{n-s}|}{|a_0| + |a_{n-s}|} \right) \frac{|p(z)|^2}{n} - s \right] \right\}^{1/2}.$$

Taking $s = 0$, and noting that $|a_0| \geq |a_{n-s}|$, it can easily be seen that Corollary 4 is an improvement of a result due to Aziz [1, Theorem 4].

We next prove the following:

Theorem 5. *Let $r \in \mathcal{R}_n$ be such that all zeros of $r(z)$ lie in $T_k \cup D_k^-$, $k \leq 1$ with an s -fold zero at the origin, then for some γ with $|\gamma| \leq 1$ and for any $z \in T_1$*

$$\left| zr'(z) + \frac{\gamma}{2} \left(|B'(z)| + \frac{2ks + n(1-k)}{1+k} \right) r(z) \right| \geq \left| \left(1 + \frac{\gamma}{2} \right) |B'(z)| + \frac{\gamma}{2} \left(\frac{2ks + n(1-k)}{1+k} \right) \right| \inf_{z \in T_k} |r(z)|.$$

By taking $s = 0$, $k = 1$, Theorem 5 reduces to the result due to Hans et al. [8, Theorem 1].

Again substituting for $r(z)$, $r'(z)$ and $|B'(z)|$ the values as in Corollary 3 and letting $|\alpha| \rightarrow \infty$, we get the next property from Theorem 5.

Corollary 5. *Let $p \in \mathcal{P}_n$ be such that all the zeros of a polynomial $p(z)$ lie in $T_k \cup D_k^-$ except an s -fold zero at the origin, then for some γ with $|\gamma| \leq 1$ and for any $z \in T_1$*

$$\left| zp'(z) + \frac{\gamma}{2} \left(n + \frac{2ks + n(1-k)}{1+k} \right) p(z) \right| \geq \left| \left(1 + \frac{\gamma}{2} \right) n + \frac{\gamma}{2} \left(\frac{2ks + n(1-k)}{1+k} \right) \right| \min_{z \in T_k} |p(z)|. \quad (2.2)$$

Remark 2. For $s = 0$, $k = 1$, (2.2) reduces to a result due to Dewan and Hans [6, Theorem 1].

3. Lemmas

For the proof of these theorems we need the following lemmas.

Lemma 1. *If*

$$B(z) = \prod_{j=1}^n \frac{1 - \overline{\alpha_j} z}{z - \alpha_j}.$$

Then for $z \in T_1$

$$\operatorname{Re} \left(\frac{zw'(z)}{w(z)} \right) = \frac{n - |B'(z)|}{2}.$$

The above lemma is due to Aziz and Zargar [3].

Lemma 2. *If $(x_j)_{j=1}^{\infty}$ be a sequence of real numbers such that $x_j \geq 1$, $j \in \mathbb{N}$. Then*

$$\sum_{j=1}^n \frac{1 - x_j}{1 + x_j} \leq \frac{1 - \prod_{j=1}^n x_j}{1 + \prod_{j=1}^n x_j}$$

for all $n \in \mathbb{N}$.

The proof of Lemma 2 is a simple consequence of the principle of mathematical induction.

Lemma 3. *Suppose $r \in \mathcal{R}_n$ and if t_1, t_2, \dots, t_n are the zeros of $B(z) + \lambda$ and s_1, s_2, \dots, s_n are the zeros of $B(z) - \lambda$, $\lambda \in T_1$, then for $z \in T_1$*

$$|r'(z)|^2 + |r^*(z)|^2 \leq \frac{|B'(z)|^2}{2} \left\{ \left(\max_{1 \leq j \leq n} |r(t_j)| \right)^2 + \left(\max_{1 \leq j \leq n} |r(s_j)| \right)^2 \right\}.$$

The above lemma is due to Aziz and Shah [2].

Lemma 4. *Let $r \in \mathcal{R}_n$ be such that all zeros of $r(z)$ lie in $T_k \cup D_k^-$, $k \leq 1$ with s -fold zeros at the origin, then for $z \in T_1$*

$$|zr'(z)| \geq \frac{1}{2} \left(|B'(z)| + \frac{1}{1+k} (2ks + n(1-k)) \right) |r(z)|.$$

The above lemma follows from a result due to Akhter et al. [4].

Next lemma is due to Li, Mohapatra and Rodriguez [10].

Lemma 5. *If A and B are two complex numbers, then*

- (i) *if $|A| \geq |B|$ and $B \neq 0$, then $A \neq vB$ for some complex number v with $|v| < 1$;*
- (ii) *conversely, if $A \neq vB$ for some complex number v , with $|v| < 1$, then $|A| \geq |B|$.*

4. Proofs of Theorems

Proof of Theorem 2. Since

$$r(z) = \frac{z^s h(z)}{w(z)},$$

where

$$h(z) = a_0 + \sum_{j=1}^{m-s} a_j z^j.$$

This implies

$$\frac{zr'(z)}{r(z)} = s + \frac{zh'(z)}{h(z)} - \frac{zw'(z)}{w(z)}.$$

Equivalently, we get

$$\operatorname{Re} \left(\frac{zr'(z)}{r(z)} \right) = s + \operatorname{Re} \left(\frac{zh'(z)}{h(z)} \right) - \operatorname{Re} \left(\frac{zw'(z)}{w(z)} \right).$$

Let z_1, z_2, \dots, z_{m-s} be the zeros of $h(z)$, such that $|z_j| \geq k > 1$. In particular for $z \in T_1$, we get by using Lemma 1.

$$\begin{aligned} \operatorname{Re} \left(\frac{zr'(z)}{r(z)} \right) &= s + \operatorname{Re} \left(\sum_{j=1}^{m-s} \frac{z}{z - z_j} \right) - \operatorname{Re} \left(\frac{zw'(z)}{w(z)} \right) \\ &\leq s + \sum_{j=1}^{m-s} \frac{1}{1 + |z_j|} - \operatorname{Re} \left(\frac{zw'(z)}{w(z)} \right) \\ &= s + \frac{m-s}{1+k} + \sum_{j=1}^{m-s} \left(\frac{1}{1 + |z_j|} - \frac{1}{1+k} \right) - \left(\frac{n - |B'(z)|}{2} \right) \\ &= s + \frac{m-s}{1+k} + \frac{k}{1+k} \sum_{j=1}^{m-s} \frac{k - |z_j|}{k + |z_j|k} - \left(\frac{n - |B'(z)|}{2} \right) \\ &\leq s + \frac{m-s}{1+k} + \frac{k}{1+k} \sum_{j=1}^{m-s} \frac{k - |z_j|}{k + |z_j|} - \left(\frac{n - |B'(z)|}{2} \right). \end{aligned}$$

Now using Lemma 2 with $|z_j|/k \geq 1$, we get

$$\begin{aligned} \operatorname{Re} \left(\frac{zr'(z)}{r(z)} \right) &\leq s + \frac{m-s}{1+k} + \frac{k}{1+k} \left(\frac{1 - \prod_{j=1}^{m-s} |z_j|/k}{1 + \prod_{j=1}^{m-s} |z_j|/k} \right) - \left(\frac{n - |B'(z)|}{2} \right) \\ &= s + \frac{m-s}{1+k} + \frac{k}{1+k} \left(\frac{k^{m-s} |a_{m-s}| - |a_0|}{k^{m-s} |a_{m-s}| + |a_0|} - \left(\frac{n - |B'(z)|}{2} \right) \right) \tag{4.3} \\ &= \frac{1}{2} \left\{ |B'(z)| + \frac{2m - n(1+k)}{1+k} + \frac{2sk}{1+k} - \frac{2k}{1+k} \left(\frac{|a_0| - k^{m-s} |a_{m-s}|}{|a_0| + k^{m-s} |a_{m-s}|} \right) \right\}. \end{aligned}$$

Now

$$r^*(z) = B(z) \overline{r(1/\bar{z})},$$

therefore using the fact that

$$\frac{zB'(z)}{B(z)} = |B'(z)|,$$

(see also [10]) we get for any $z \in T_1$

$$|r^{*'}(z)| = |B'(z)r(z) - zr'(z)|.$$

This implies for $z \in T_1$

$$\left| \frac{zr^{*'}(z)}{r(z)} \right|^2 = \left| B'(z) - \frac{zr'(z)}{r(z)} \right|^2 = |B'(z)|^2 + \left| \frac{zr'(z)}{r(z)} \right|^2 - 2|B'(z)|\operatorname{Re} \left(\frac{zr'(z)}{r(z)} \right). \quad (4.4)$$

Now using (4.3) in (4.4), we get

$$\begin{aligned} \left| \frac{zr^{*'}(z)}{r(z)} \right|^2 &\geq |B'(z)|^2 + \left| \frac{zr'(z)}{r(z)} \right|^2 \\ &- |B'(z)| \left(|B'(z)| + \frac{2m - n(1+k)}{1+k} + \frac{2sk}{1+k} - \frac{2k}{1+k} \left(\frac{|a_0| - k^{m-s}|a_{m-s}|}{|a_0| + k^{m-s}|a_{m-s}|} \right) \right). \end{aligned}$$

This gives for $z \in T_1$

$$|r^{*'}(z)|^2 \geq |r'(z)|^2 + \left\{ \frac{2k}{1+k} \left(\frac{|a_0| - k^{m-s}|a_{m-s}|}{|a_0| + k^{m-s}|a_{m-s}|} \right) - \frac{2sk}{1+k} - \frac{2m - n(1+k)}{1+k} \right\} |B'(z)||r(z)|^2.$$

This implies

$$\begin{aligned} 2|r'(z)|^2 + \left\{ \frac{2k}{1+k} \left(\frac{|a_0| - k^{m-s}|a_{m-s}|}{|a_0| + k^{m-s}|a_{m-s}|} \right) - \frac{2sk}{1+k} - \frac{2m - n(1+k)}{1+k} \right\} |B'(z)||r(z)|^2 \\ \leq |r'(z)|^2 + |r^{*'}(z)|^2. \end{aligned}$$

Using Lemma 3, we get

$$\begin{aligned} 2|r'(z)|^2 + \left\{ \frac{2k}{1+k} \left(\frac{|a_0| - k^{m-s}|a_{m-s}|}{|a_0| + k^{m-s}|a_{m-s}|} \right) - \frac{2sk}{1+k} - \frac{2m - n(1+k)}{1+k} \right\} |B'(z)||r(z)|^2 \\ \leq \frac{|B'(z)|^2}{2} \left\{ \left(\max_{1 \leq j \leq n} |r(t_j)| \right)^2 + \left(\max_{1 \leq j \leq n} |r(s_j)| \right)^2 \right\}. \end{aligned}$$

On simplification, it follows that

$$\begin{aligned} |r'(z)| &\leq \frac{|B'(z)|}{2} \left\{ \left(\max_{1 \leq j \leq n} |r(t_j)| \right)^2 + \left(\max_{1 \leq j \leq n} |r(s_j)| \right)^2 \right\} \\ &- 4 \left[\left(\frac{k}{1+k} \left(\frac{|a_0| - k^{m-s}|a_{m-s}|}{|a_0| + k^{m-s}|a_{m-s}|} \right) - \frac{sk}{1+k} - \frac{2m - n(1+k)}{2(1+k)} \right) \frac{|r(z)|^2}{|B'(z)|} \right]^{1/2}. \end{aligned}$$

This completely proves Theorem 2. □

Proof of Theorem 3. Suppose $r(z)$ has a zero on T_k , then

$$m = \inf_{z \in T_k} |r(z)| = 0$$

and the result holds trivially. We assume all the zeros of $r(z)$ lie in $D_k^-, k \leq 1$ with an s -fold zero at the origin. So that $m > 0$ and for $z \in D_k^-, |r(z)| \geq m$.

Since $|B(z)| \leq 1$ for $z \in T_1 \cup D_1^-$ (see [7, p. 40]), therefore $|B(z)| \leq 1$ for $z \in T_k, k \leq 1$. Hence it follows by Rouché's theorem that for some δ with $|\delta| < 1$,

$$F(z) = r(z) - \delta m B(z)$$

has all zeros in $D_k^-, k \leq 1$. Applying Lemma 4 to $F(z)$, we get for $z \in T_1$

$$|zF'(z)| \geq \frac{1}{2} \left\{ \frac{2ks + n(1 - k)}{1 + k} + |B'(z)| \right\} |F(z)|.$$

That is for $z \in T_1$

$$\left| zr'(z) - \delta mzB'(z) \right| \geq \frac{1}{2} \left\{ \frac{2ks + n(1 - k)}{1 + k} + |B'(z)| \right\} |r(z) - \delta mB(z)|.$$

Since $F(z) \neq 0$ in $T_k \cup D_k^+$, therefore for any complex number γ with $|\gamma| \leq 1$, we have from (i) of Lemma 5,

$$T(z) = zr'(z) - \delta mzB'(z) + \gamma \left\{ \frac{2ks + n(1 - k)}{2(1 + k)} + \frac{|B'(z)|}{2} \right\} (r(z) - \delta mB(z)) \neq 0.$$

This gives for $z \in T_1$

$$\begin{aligned} T(z) &= zr'(z) + \frac{\gamma}{2} \left\{ \frac{2ks + n(1 - k)}{1 + k} + |B'(z)| \right\} r(z) \\ &\quad - \delta m \left[zB'(z) + \frac{\gamma}{2} \left\{ \frac{2ks + n(1 - k)}{1 + k} + |B'(z)| \right\} B(z) \right] \neq 0. \end{aligned}$$

Now using (ii) part of Lemma 5, we get for $|\delta| < 1, |\gamma| \leq 1$ and $k \leq 1$

$$\left| zr'(z) + \frac{\gamma}{2} \left\{ \frac{2ks + n(1 - k)}{1 + k} + |B'(z)| \right\} r(z) \right| \geq m \left| zB'(z) + \frac{\gamma B(z)}{2} \left\{ \frac{2ks + n(1 - k)}{1 + k} + |B'(z)| \right\} \right|.$$

Equivalently for $z \in T_1$, we have

$$\begin{aligned} &\left| zr'(z) + \frac{\gamma}{2} \left\{ \frac{2ks + n(1 - k)}{1 + k} + |B'(z)| \right\} r(z) \right| \\ &\geq \left| \left(1 + \frac{\gamma}{2} \right) |B'(z)| + \frac{\gamma}{2} \left(\frac{2ks + n(1 - k)}{1 + k} \right) \right| \inf_{z \in T_k} |r(z)|. \end{aligned}$$

This completely proves Theorem 3. □

Acknowledgements

The authors are highly grateful to the referee for his/her useful suggestions.

REFERENCES

1. Aziz A. A refinement of an inequality of S. Bernstein. *J. Math. Anal. Appl.*, 1989. Vol. 142, No. 1. P. 226–235. DOI: [10.1016/0022-247X\(89\)90370-3](https://doi.org/10.1016/0022-247X(89)90370-3)
2. Aziz A., Shah W. M. Some refinements of Bernstein-type inequalities for rational functions. *Glas. Math.*, 1997. Vol. 32, No. 1. P. 29–37.
3. Aziz-Ul-Auzeem A., Zargar B. A. Some properties of rational functions with prescribed poles. *Canad. Math. Bull.*, 1999. Vol. 42, No. 4. P. 417–426. DOI: [10.4153/CMB-1999-049-0](https://doi.org/10.4153/CMB-1999-049-0)
4. Akhter T., Malik S. A., Zargar B. A. Turán type inequalities for rational functions with prescribed poles. *Int. J. Nonlinear Anal. Appl.*, 2022. Vol. 13, No. 1. P. 1003–1009. DOI: [10.22075/ijnaa.2021.23145.2484](https://doi.org/10.22075/ijnaa.2021.23145.2484)
5. Bernstein S. N. Sur la limitation des dérivées des polynomes. *C. R. Acad. Sci. Paris*, 1930. Vol 190. P. 338–340. (in French)

6. Dewan K. K., Hans S. Generalization of certain well-known polynomial inequalities. *J. Math Anal. Appl.*, 2010. Vol. 363, No. 1. P. 38–41. DOI: [10.1016/j.jmaa.2009.07.049](https://doi.org/10.1016/j.jmaa.2009.07.049)
7. Garcia S. R., Mashreghi J., Ross W. T. *Finite Blaschke Products and Their Connections*. Cham: Springer, 2018. 328 p. DOI: [10.1007/978-3-319-78247-8](https://doi.org/10.1007/978-3-319-78247-8)
8. Hans S., Tripathi D., Mogbademu A. A., Babita Tyagi. Inequalities for rational functions with prescribed poles. *J. Interdiscip. Math.*, 2018. Vol. 21, No. 1. P. 157–169. DOI: [10.1080/09720502.2015.1033837](https://doi.org/10.1080/09720502.2015.1033837)
9. Lax P. D. Proof of a conjecture of P. Erdős on the derivative of a polynomial. *Bull. Amer. Math. Soc.*, 1944. Vol. 50. P. 509–513. DOI: [10.1090/S0002-9904-1944-08177-9](https://doi.org/10.1090/S0002-9904-1944-08177-9)
10. Li X., Mohapatra R. N., Rodriguez R. S. Bernstein-type inequalities for rational functions with prescribed poles. *J. London Math. Soc.*, 1995. Vol. 51. P. 523–531. DOI: [10.1112/jlms/51.3.523](https://doi.org/10.1112/jlms/51.3.523)
11. Turán P. Über die ableitung von polynomen. *Compos. Math.*, 1939. Vol. 7. P. 89–95. (in German)
12. Wali S. L., Shah W. M. Applications of the Schwarz lemma to inequalities for rational functions with prescribed poles. *J. Anal.*, 2017. Vol. 25, No. 1. P. 43–53. DOI: [10.1007/s41478-016-0025-2](https://doi.org/10.1007/s41478-016-0025-2)

ON CAUCHY-TYPE BOUNDS FOR THE EIGENVALUES OF A SPECIAL CLASS OF MATRIX POLYNOMIALS

Zahid Bashir Monga[†], Wali Mohammad Shah^{††}

Department of Mathematics, Central University of Kashmir,
Ganderbal-191201, India

[†]zahidmonga@cukashmir.ac.in ^{††}wali@cukashmir.ac.in

Abstract: Let $\mathbb{C}^{m \times m}$ be the set of all $m \times m$ matrices whose entries are in \mathbb{C} , the set of complex numbers. Then $P(z) := \sum_{j=0}^n A_j z^j$, $A_j \in \mathbb{C}^{m \times m}$, $0 \leq j \leq n$ is called a matrix polynomial. If $A_n \neq 0$, then $P(z)$ is said to be a matrix polynomial of degree n . In this paper we prove some results for the bound estimates of the eigenvalues of some lacunary type of matrix polynomials.

Keywords: Matrix polynomial, Eigenvalue, Positive-definite matrix, Cauchy's theorem, Spectral radius.

1. Introduction

Let $\mathbb{C}^{m \times m}$ be the set of all $m \times m$ matrices whose entries are in \mathbb{C} , the set of complex numbers. For a matrix polynomial we mean the matrix-valued function of a complex variable of the form

$$P(z) := \sum_{j=0}^n A_j z^j, \quad A_j \in \mathbb{C}^{m \times m}, \quad 0 \leq j \leq n.$$

If $A_n \neq 0$, then $P(z)$ is called a matrix polynomial of degree n .

A complex number λ is said to be an eigenvalue of the matrix polynomial $P(z)$, if there exists a nonzero vector $u \in \mathbb{C}^m$, such that $P(\lambda)u = 0$. The vector u is called an eigenvector of $P(z)$ associated to the eigenvalue λ .

For matrices $A, B \in \mathbb{C}^{m \times m}$, we write $A \geq 0$ or $A > 0$, if A is positive semi-definite or positive definite respectively. By $A \geq B$, we mean $A - B \geq 0$ and $A > B$, means $A - B > 0$.

We denote by $\lambda_{max}(A)$ and $\lambda_{min}(A)$ the maximum and minimum eigenvalues of a Hermitian matrix A respectively. Also the spectral radius denoted by $\rho(A)$ of a matrix A is defined by

$$\rho(A) = \max \{ |\lambda| : \lambda \text{ is an eigenvalue of } A \}.$$

The identity matrix and the conjugate transpose of a vector u are respectively denoted by I and u^* . Also for $\alpha \geq 0$, denote the open disk

$$K^*(0, \alpha) := \{ z \in \mathbb{C} : |z| < \alpha \}$$

and the closed disk

$$K(0, \alpha) := \{ z \in \mathbb{C} : |z| \leq \alpha \}.$$

Polynomial eigenvalue problems have vital applications in a wide range of science and engineering fields (see for example [4, 9]). It is generally challenging to compute the eigenvalues of a matrix polynomial, but bounds on such eigenvalues are relatively easy to obtain. These bounds

can be used by iterative methods to calculate them and are also valuable for the computation of pseudospectra.

A simple but classical result due to Cauchy [2; 7, Theorem 27.1, p. 122] on the location of zeros of a polynomial with complex coefficients states:

Theorem 1. *Let*

$$p(z) := \sum_{j=0}^n a_j z^j, \quad a_n \neq 0$$

be a polynomial of degree n with complex coefficients. Then the zeros of $p(z)$ lie in $\{z : |z| < \rho\}$, where ρ is the unique positive root of the equation

$$|a_n|z^n - |a_{n-1}|z^{n-1} - \dots - |a_1|z - |a_0| = 0.$$

An extension to matrix polynomials of Cauchy's classical result was obtained in [1, 5, 8]. It states:

Theorem 2. *Let*

$$P(z) := \sum_{j=0}^n A_j z^j, \quad \det(A_n) \neq 0$$

be a matrix polynomial. Then the eigenvalues of $P(z)$ lie in $|z| \leq \rho$, where ρ is the unique positive root of the equation

$$\|A_n^{-1}\|^{-1}z^n - \|A_{n-1}\|z^{n-1} - \dots - \|A_1\|z - \|A_0\| = 0.$$

Throughout this paper, $\|\cdot\|$ denotes a subordinate matrix norm.

2. Main results

We call a matrix polynomial lacunary, if some of its coefficients are missing. In this paper, we obtain bounds for the eigenvalues of a class of lacunary matrix polynomials. The first result we prove in this paper states:

Theorem 3. *Let*

$$P(z) := Iz^n - Iz^{n-1} - A_1z + A_0, \quad \|A_0\| \cdot \|A_1\| \neq 0, \quad n > 2$$

be a matrix polynomial. Then the eigenvalues of $P(z)$ lie in $K(0, \delta)$, where $\delta > 1$ is the largest positive root of the equation

$$z^{n+1} - 2z^n - \|A_1\|z^2 + (\|A_1\| - \|A_0\|)z + \|A_0\| = 0.$$

P r o o f. Let u be a unit vector, then we have for $|z| > 1$,

$$\begin{aligned} \|P(z)u\| &= \|uz^n - uz^{n-1} - A_1uz + A_0u\| \\ &\geq |z|^n - \|uz^{n-1} + A_1uz - A_0u\| \\ &\geq |z|^n - |z|^{n-1} - \|A_1\||z| - \|A_0\| \\ &= |z|^n \left(1 - \left(\frac{1}{|z|} + \|A_1\| \frac{1}{|z|^{n-1}} + \|A_0\| \frac{1}{|z|^n} \right) \right) \\ &> |z|^n \left(1 - \left(\frac{1}{|z|-1} + \|A_1\| \frac{1}{|z|^{n-1}} + \|A_0\| \frac{1}{|z|^n} \right) \right) \\ &= \frac{1}{|z|-1} (|z|^{n+1} - 2|z|^n - \|A_1\||z|^2 + (\|A_1\| - \|A_0\|)|z| + \|A_0\|) \\ &= \frac{1}{|z|-1} H(|z|), \end{aligned} \tag{2.1}$$

where

$$H(z) = z^{n+1} - 2z^n - \|A_1\|z^2 + (\|A_1\| - \|A_0\|)z + \|A_0\|.$$

Here $H(z)$ has two sign changes within its sequence of coefficients and $H(0) = \|A_0\| > 0$ and $H(1) = -1 < 0$, therefore by Descartes' rule of signs $H(z)$ has two positive zeros. Let δ be the largest positive zero of $H(z)$, then $H(|z|) > 0$ if $|z| > \delta$. Noting that $\delta > 1$, therefore from (2.1), we have

$$\|P(z)u\| > 0 \quad \text{if } |z| > \delta.$$

Hence the eigenvalues of $P(z)$ lie in the closed disk $K(0, \delta)$, where $\delta > 1$ is the largest positive root of $H(z)$. □

The following result can be deduced from the above theorem.

Corollary 1. *Let*

$$P(z) := Iz^n - Iz^{n-1} - A_1z + A_0, \quad \|A_0\| \cdot \|A_1\| \neq 0, \quad n > 2$$

be a matrix polynomial. Then the eigenvalues of $P(z)$ lie in $K(0, \delta')$, where $\delta' > 1$ is the largest positive root of the equation

$$z^{n+1} - 2z^n - Mz^2 + M = 0$$

and

$$M = \max(\|A_1\|, \|A_0\|).$$

P r o o f. Let

$$H(z) = z^{n+1} - 2z^n - \|A_1\|z^2 + (\|A_1\| - \|A_0\|)z + \|A_0\|.$$

Then we have for $|z| \geq 1$

$$\begin{aligned} H(|z|) &= |z|^{n+1} - 2|z|^n - \|A_1\||z|^2 + (\|A_1\| - \|A_0\|)|z| + \|A_0\| \\ &= |z|^{n+1} - 2|z|^n - \|A_1\|(|z|^2 - |z|) - \|A_0\|(|z| - 1) \\ &\geq |z|^{n+1} - 2|z|^n - M(|z|^2 - |z|) - M(|z| - 1) \\ &= |z|^{n+1} - 2|z|^n - M|z|^2 + M = G(|z|), \end{aligned} \tag{2.2}$$

where

$$G(z) = z^{n+1} - 2z^n - Mz^2 + M.$$

Since $\|A_0\| \cdot \|A_1\| \neq 0$, therefore $M \neq 0$ and hence $G(z)$ has two sign changes within its sequence of coefficients. Also $G(0) = M > 0$ and $G(1) = -1 < 0$, thus by Descartes rule of signs $G(z)$ has two positive zeros. Let $\delta' > 1$ be the largest positive zero of $G(z)$. Therefore from (2.2), we have

$$H(|z|) \geq G(|z|) > 0 \quad \text{if } |z| > \delta'.$$

Thus

$$H(|z|) > 0 \quad \text{if } |z| > \delta'.$$

Thus $\delta \leq \delta'$, where δ is the largest positive zero of $H(z)$. However by Theorem 3 all eigenvalues of $P(z)$ lie in $K(0, \delta)$, therefore

$$K(0, \delta) \subseteq K(0, \delta').$$

This proves the corollary. □

We next prove the following results which give bounds on the eigenvalues of a matrix polynomial in terms of the norms of coefficient matrices.

Theorem 4. *Let*

$$P(z) := Iz^n - Iz^{n-1} - A_1z + A_0, \quad \|A_0\| \cdot \|A_1\| \neq 0, \quad n > 2$$

be a matrix polynomial. Then the eigenvalues of $P(z)$ lie in the closed disk

$$K\left(0, (1 + \sqrt{1 + 4\|A_0\| + 4\|A_1\|})/2\right).$$

P r o o f. Let u be a unit vector. Then just as in the proof of the Theorem 3, we have for $|z| > 1$

$$\begin{aligned} \|P(z)u\| &\geq |z|^n - (|z|^{n-1} + \|A_1\||z| + \|A_0\|) \\ &> |z|^n - (|z|^{n-1} + \|A_1\||z|^{n-2} + \|A_0\||z|^{n-2}) \\ &= |z|^{n-2}(|z|^2 - |z| - \|A_1\| - \|A_0\|) = |z|^{n-2}H(|z|), \end{aligned} \quad (2.3)$$

where

$$H(z) = z^2 - z - \|A_1\| - \|A_0\|.$$

Now $H(z) = 0$ implies

$$z = \frac{1 \pm \sqrt{1 + 4\|A_1\| + 4\|A_0\|}}{2}.$$

Also $\lim_{z \rightarrow \infty} H(z) = \infty$, thus if

$$|z| > \frac{1 + \sqrt{1 + 4\|A_1\| + 4\|A_0\|}}{2},$$

then $H(|z|) > 0$. This implies from (2.3) that for $|z| > 1$

$$\|P(z)u\| > 0 \quad \text{if} \quad |z| > \frac{1 + \sqrt{1 + 4\|A_1\| + 4\|A_0\|}}{2}.$$

We note that

$$\frac{1 + \sqrt{1 + 4\|A_1\| + 4\|A_0\|}}{2} > 1,$$

therefore the eigenvalues of $P(z)$ lie in the closed disk $K\left(0, (1 + \sqrt{1 + 4\|A_1\| + 4\|A_0\|})/2\right)$. \square

It is clear that if $\rho > 0$ then

$$1 + \rho > \frac{1}{2}(1 + \sqrt{1 + 4\rho})$$

and therefore we have the following:

Corollary 2. *Let*

$$P(z) := Iz^n - Iz^{n-1} - A_1z + A_0, \quad \|A_0\| \cdot \|A_1\| \neq 0, \quad n > 2$$

be a matrix polynomial. Then the eigenvalues of $P(z)$ lie in the open disk $K^(0, 1 + \|A_0\| + \|A_1\|)$.*

The next result which we prove gives an upper bound for the positive eigenvalues. For the proof we need the following lemmas.

Lemma 1 [3]. *If the real polynomial*

$$p(z) = z^n - z^{n-1} - a_1z + a_0, \quad a_1a_0 > 0, \quad n > 2,$$

has two positive zeros, its largest positive zero δ satisfies $\delta < 1 + \sqrt{a_1}$.

The above lemma is due to Dehmer and Mowshowitz [3]. We also need the following lemma.

Lemma 2 [6, p. 235]. *Let $M \in \mathbb{C}^{m \times m}$ be a Hermitian matrix, then*

$$\lambda_{\min}(M) = \min_{u \in \mathbb{C}^m, u^*u=1} \{u^*Mu\}$$

and

$$\lambda_{\max}(M) = \max_{u \in \mathbb{C}^m, u^*u=1} \{u^*Mu\}.$$

Theorem 5. *Let*

$$P(z) =: Iz^n - Iz^{n-1} - A_1z + A_0, \quad A_1 \geq A_0 > 0, \quad n > 2$$

be a matrix polynomial. If λ is a positive eigenvalue of $P(z)$, then

$$\lambda < 1 + \sqrt{\|A_1\|}.$$

P r o o f. Let u be a unit vector. Define

$$P_u(z) = u^*P(z)u = z^n - z^{n-1} - u^*A_1uz + u^*A_0u.$$

Then $P_u(z)$ is a polynomial with complex coefficients. Also since $A_0 > 0$, therefore $P_u(z)$ has two sign changes within its sequence of coefficients. Moreover $P_u(0) = u^*A_0u > 0$ and

$$P_u(1) = u^*A_0u - u^*A_1u = u^*(A_0 - A_1)u \leq 0,$$

therefore by Descartes' rule of signs $P_u(z)$ has two positive roots. Hence by Lemma 1, the largest positive zero δ_u of $P_u(z)$ satisfies

$$\delta_u < 1 + \sqrt{u^*A_1u}.$$

Thus by Lemma 2, we have

$$\delta_u < 1 + \sqrt{\lambda_{\max}(A_1)} \leq 1 + \sqrt{\|A_1\|}. \tag{2.4}$$

Let λ be a positive eigenvalue of $P(z)$, then λ is a zero of $P_u(z)$ for some unit vector u and therefore by (2.4), we have

$$\lambda < 1 + \sqrt{\|A_1\|}.$$

This proves the theorem. □

Taking $A_1 = I$ in Theorem 5, we get the following:

Corollary 3. *Let*

$$P(z) =: Iz^n - Iz^{n-1} - Iz + A_0, \quad I \geq A_0 > 0, \quad n > 2$$

be a matrix polynomial. If λ is a positive eigenvalue of $P(z)$, then $\lambda < 2$.

The next theorem gives a bound on the eigenvalues of another class of lacunary matrix polynomials.

Theorem 6. *Let*

$$P(z) =: Iz^n - A_1z + A_0, \quad \|A_0\| \cdot \|A_1\| \neq 0, \quad n > 2$$

be a matrix polynomial. Then the eigenvalues of $P(z)$ lie in the closed disk

$$K \left(0, (\|A_1\| + \sqrt{\|A_1\|^2 + 4\|A_0\| + 4})/2 \right).$$

P r o o f. Let u be a unit vector. Then just as in the proof of the Theorem 3, we have for $|z| > 1$,

$$\begin{aligned} \|P(z)u\| &\geq |z|^n - \|A_1\||z| - \|A_0\| \\ &> |z|^n - (\|A_1\||z|^{n-1} + \|A_0\||z|^{n-2} + |z|^{n-2}) \\ &= |z|^{n-2}(|z|^2 - \|A_1\||z| - \|A_0\| - 1) = |z|^{n-2}H(|z|), \end{aligned} \quad (2.5)$$

where

$$H(z) = z^2 - \|A_1\|z - \|A_0\| - 1.$$

Now $H(z) = 0$ implies

$$z = \frac{\|A_1\| \pm \sqrt{\|A_1\|^2 + 4\|A_0\| + 4}}{2}.$$

Thus $H(|z|) > 0$ if

$$|z| > \frac{\|A_1\| + \sqrt{\|A_1\|^2 + 4\|A_0\| + 4}}{2}.$$

Also noting that

$$\frac{\|A_1\| + \sqrt{\|A_1\|^2 + 4\|A_0\| + 4}}{2} > 1.$$

therefore from (2.5), we have

$$\|P(z)u\| > 0 \quad \text{if} \quad |z| > \frac{\|A_1\| + \sqrt{\|A_1\|^2 + 4\|A_0\| + 4}}{2}.$$

Therefore the eigenvalues of $P(z)$ lie in the closed disk

$$K \left(0, (\|A_1\| + \sqrt{\|A_1\|^2 + 4\|A_0\| + 4})/2 \right).$$

□

The next result is obtained on restricting the coefficient matrices. For the proof we need the following lemma due to Dehmer and Mowshowitz [3].

Lemma 3 [3]. *If the real polynomial*

$$p(z) = z^n - a_1z + a_0, \quad a_1a_0 > 0, \quad n > 2,$$

has two positive zeros, its largest positive zero satisfies

$$\delta < \frac{1 + \sqrt{4a_1 + 1}}{2}.$$

Theorem 7. *Let*

$$P(z) =: Iz^n - A_1z + A_0, \quad A_1 \geq I + A_0, \quad A_0 > 0, \quad n > 2$$

be a matrix polynomial. If λ is a positive eigenvalue of $P(z)$, then

$$\lambda < \frac{1 + \sqrt{4\|A_1\| + 1}}{2}.$$

P r o o f. Let u be a unit vector and $P_u(z) = u^*P(z)u$. Then since

$$P(z) = Iz^n - A_1z + A_0,$$

we have

$$P_u(z) = z^n - u^*A_1uz + u^*A_0u.$$

Now by hypothesis

$$P_u(1) = 1 - u^*A_1u + u^*A_0u = u^*(I - A_1 + A_0)u \leq 0$$

and

$$P_u(0) = u^*A_0u > 0.$$

Also $P_u(z)$ has two sign changes within its sequence of coefficients, therefore by Descartes' rule of signs $P_u(z)$ has two positive zeros. Hence by Lemma 3, the largest positive zero δ_u of $P_u(z)$ satisfies

$$\delta_u < \frac{1 + \sqrt{4u^*A_1u + 1}}{2}.$$

This gives on using Lemma 2

$$\delta_u < \frac{1 + \sqrt{4\lambda_{\max}(A_1) + 1}}{2} \leq \frac{1 + \sqrt{4\|A_1\| + 1}}{2}.$$

In the same way as in Theorem 5, we conclude that any positive eigenvalue λ of $P(z)$ satisfies

$$\lambda < \frac{1 + \sqrt{4\|A_1\| + 1}}{2}.$$

□

For $m = 1$, the matrices A_j reduce to $a_j \in \mathbb{C}$ and therefore in this case the above results reduce to various theorems proved by Dehmer and Mowshowitz [3].

The bounds obtained in Theorem 3–5 are incomparable. We consider the following examples:

Example 1. Let $n = 3$, $\|A_0\| = \|A_1\| = \|A\|$ for some matrix A . Then if $\|A\| = 1$, we have

$$\delta = 2.3485 > 2 = \frac{1 + \sqrt{1 + 4\|A_0\| + 4\|A_1\|}}{2}.$$

However, if $\|A\| = 6$, then

$$\delta = 3.5544 < 4 = \frac{1 + \sqrt{1 + 4\|A_0\| + 4\|A_1\|}}{2}.$$

Example 2. Let $\|A_0\| = \|A_1\| = 3$, then

$$\frac{1 + \sqrt{1 + 4\|A_0\| + 4\|A_1\|}}{2} = 3 > 1 + \sqrt{3} = 1 + \sqrt{\|A_1\|}.$$

However, if $\|A_0\| = \|A_1\| = 1/2$, then

$$\frac{1 + \sqrt{1 + 4\|A_0\| + 4\|A_1\|}}{2} = 1.618 < 1.7071 = 1 + \sqrt{\|A_1\|}.$$

Example 3. Assume $\|A_0\| = \|A_1\| = \|A\|$ for some matrix A . Then if $n = \|A\| = 4$ we have

$$\delta = 2.5279 < 3 = 1 + \sqrt{\|A_1\|}.$$

However, if $n = 3$ and $\|A\| = 6$ then

$$\delta = 3.5544 > 3.44 = 1 + \sqrt{\|A_1\|}.$$

Note, we used Desmos, an online graphing calculator and mathematical tool, for the calculations.

Acknowledgements

The authors are highly grateful to the referees for their useful suggestions.

REFERENCES

1. Bini D.A., Noferini V., Sharify M. Locating the eigenvalues of matrix polynomials. *SIAM J. Matrix Anal. Appl.*, 2013. Vol. 34, No. 4. P. 1708–1727. DOI: [10.1137/120886741](https://doi.org/10.1137/120886741)
2. Cauchy A.-L. *Mémoire sur la Résolution des Équations numériques et sur la Théorie de l'Élimination*. Paris: de Bure Frères, 1829. 64 p. (in French)
3. Dehmer M., Mowshowitz A. Bounds on the moduli of polynomial zeros. *Appl. Math. Comp.*, 2011. Vol. 218, No. 8. P. 4128–4137. DOI: [10.1016/j.amc.2011.09.043](https://doi.org/10.1016/j.amc.2011.09.043)
4. Gohberg I., Lancaster P., Rodman L. *Matrix Polynomials*. New York: Academic Press, 1982. 433 p.
5. Higham N.J., Tisseur F. Bounds for eigenvalues of matrix polynomials. *Linear Algebra Appl.*, 2003. Vol. 358, No. 1–3. P. 5–22. DOI: [10.1016/S0024-3795\(01\)00316-0](https://doi.org/10.1016/S0024-3795(01)00316-0)
6. Horn R.A., Johnson C.R. *Matrix Analysis*. Cambridge: Cambridge University Press, 2013. 643 p. DOI: [10.1017/CBO9780511810817](https://doi.org/10.1017/CBO9780511810817)
7. Marden M. *Geometry of Polynomials*. Math. Surveys Monogr., vol. 3. Providence, RI: American Mathematical Society, 1966. 243 p.
8. Melman A. Generalization and variations of Pellet's theorem for matrix polynomials. *Linear Algebra Appl.*, 2013. Vol. 439, No. 5. P. 1550–1567. DOI: [10.1016/j.laa.2013.05.003](https://doi.org/10.1016/j.laa.2013.05.003)
9. Tisseur F., Meerbergen K. The quadratic eigenvalue problem. *SIAM Review*, 2001. Vol. 43, No. 2. P. 235–286.

SUM SIGNED GRAPHS – II

Athira P. Ranjith[†], Joseph Varghese Kureethara^{††}

Christ University,
Bangalore-560029, Karnataka, India

[†]athira.ranjith@res.christuniversity.in ^{††}frjoseph@christuniversity.in

Abstract: In this paper, the study of sum signed graphs is continued. The balancing and switching nature of the graphs are analyzed. The concept of *rna* number is revisited and an important relation between the number and its complement is established.

Keywords: Balanced signed graph, *rna* number, *rna* complement number.

1. Introduction

Consider a scenario in which there exists a road of width 5 units. Clearly, vehicles of width 1 & 2, 1 & 3, 1 & 4 and 2 & 3 pass through the road with ease whereas the vehicles of width 2 & 4 and 3 & 4 find it difficult to pass through the road simultaneously. Also, the vehicle with width 5 cannot pass with any other given vehicles. There can exist situations in which the vehicle of width 5 can pass through the road alone which is depicted in the first figure. Also, there can be situations in which such a vehicle cannot pass through the road or may not exist at all and this idea is represented in the second figure. These two situations are modelled below in which the vertices are the vehicles and the corresponding width is given as labels for the vertices. The dashed line represents the case in which two vehicles travelling together are not possible and these types of edges are the negative edges. The other case in which two vehicles can travel together is represented by the bold line or positive edge.

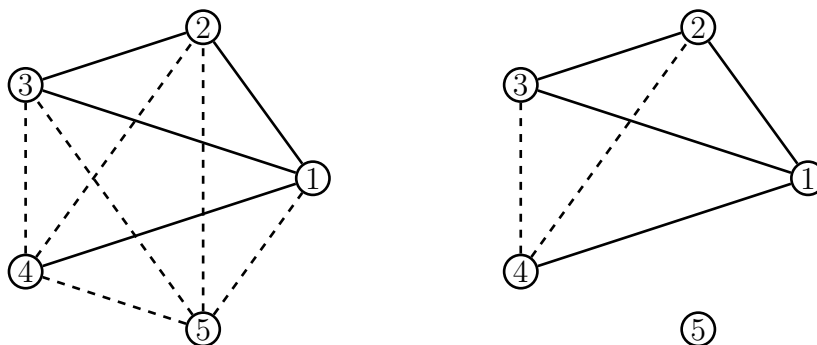

Figure 1. The illustration above gives us a picture of which all vehicles can travel together or not.

The motivation for the concept of sum signed labeling arose from the above idea that the vehicles passing through a road are sometimes restricted in terms of width of the road from a smooth, continuous ride. Introductory studies on sum signed graphs is available in [7]. In this paper, we extend the studies on sum signed graphs.

In Section 2, the criteria for switching from one sum signed graph to another will be discussed. The balance theory in the context of sum signed graphs is discussed in Section 3. An algorithm is provided in Section 4 to find the *rna* number for trees. Finally, the Section 5 introduces the concept of *rna* complement and discusses some of its properties.

2. Preliminaries

All the underlying graphs considered in this paper are simple, unless mentioned otherwise. We give the definition of the sum signed graph now.

Definition 1 [7]. A sum signed graph is a trio, $S = (G, f, \sigma)$ where G is a graph,

$$f : V(G) \longrightarrow \{1, 2, \dots, |V(G)|\}$$

is a bijective function and $\sigma : E(G) \longrightarrow \{+, -\}$ is a mapping such that $\sigma(uv) = +$, whenever $f(u) + f(v) \leq n$ and $\sigma(uv) = -$, whenever $f(u) + f(v) > n$.

An edge receiving '+' sign is said to be a positive edge and the one receiving '-' sign is said to be a negative edge. A sum signed graph is said to be homogeneous, if all the edges receive either positive or negative sign, or else the signed graph will be a heterogeneous one. For basic terminologies on unsigned graphs and signed graphs, we refer to [5] and [9].

Definition 2 [7]. The smallest number of negative edges among all sum signed labeling of its underlying graph G is called the *rna* number. It is denoted by $\sigma^-(G)$.

From a socio-psychological point of view, negation [6] of a signed graph to another is an important operation. The negation $\eta(S)$ of a signed graph S is obtained by negating every edge of S that is, by changing the sign of each edge to its opposite. When this process is done, surely a signed graph is obtained but the question arises when will that signed graph become a sum signed graph. This question is answered in the next theorem.

Theorem 1. A sum sign graph $S_1 = (G, f, \sigma)$ can be negated to another sum signed graph $S_2 = (G, g, \sigma)$ whenever

$$g(u) = n + 1 - f(u), \quad u \in V(G).$$

P r o o f. Consider that there exists a sum signed graph $S_1 = (G, f, \sigma)$ for an underlying graph G with n vertices which can be switched to $S_2 = (G, g, \sigma)$ without the stated relation between f and g . In particular, assume that the stated relation does not exist for the vertex v_i having the label n i.e., all the edges incident to the vertex v_i in S_1 is negative. Then, v_i can be assigned the label $k > 1$ in S_2 such that all edges incident to v_i in is positive. Now, consider the same procedure in which the edges incident to the vertex receive opposite signs, for the vertex v_j having the label $n - 1$ in S_1 . Proceeding like this, a contradiction will be reached at some vertex u in S_1 , where at least one of the edges of the vertex u will have the same sign in S_1 and S_2 by not admitting the condition of sum signed labeling. \square

Remark 1. In the case of $(n, 1)$ -shovel graphs [8], none of its sum signed graphs can be switched to another sum signed graph.

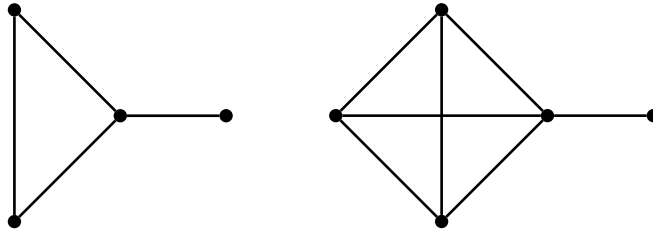

Figure 2. (3, 1) and (4, 1) shovel graphs.

3. Balanced sum signed graphs

Before diving into proving the balanced nature of sum signed graphs, we shall have a look at the topic of energy in sum signed graphs [4]. Let v_1, v_2, \dots, v_n be the vertices of a graph G and S be its sum signed graph. Then, the $n \times n$ matrix $A(S) = a_{ij}$ known as the adjacency matrix is defined as,

$$a_{ij} = \begin{cases} \sigma(v_i, v_j) & \text{if } v_i \text{ and } v_j \text{ are adjacent,} \\ 0 & \text{otherwise.} \end{cases}$$

The eigenvalues of $A(S)$ that are also the eigenvalues of S , are real in nature. The spectrum is the set of distinct eigenvalues along with their multiplicities. The graphs with same spectrum are known as cospectral. Upon observation, some interesting characteristics were seen.

Theorem 2. *Every sum signed graph of the underlying graph G which satisfies the switching function are cospectral if and only if the spectrum is symmetric about the origin.*

P r o o f. Let S be a sum signed graph of G which can be switched to another sum signed graph S_1 using the switching function above. Clearly, $S_1 = -S$ where $-S$ is the sum signed graph obtained by negating each sign of S . Then, the statement holds as proved in [4]. \square

The concept of balance in signed graphs was introduced by Harary in [6]. This concept is very relevant while applying the ideas related to signed graph in a society. A signed graph is balanced if all the cycles present in the graph are positive. Otherwise, the signed graph is said to be unbalanced. In [1], a criterion was formulated to prove the balanced nature of signed graphs in terms of spectrum. The same condition is satisfied in the case of sum signed graphs.

Theorem 3. *A sum signed graph is balanced if and only if it is cospectral with the underlying graph.*

Theorem 4. *Every sum signed complete graph K_n , where $n \geq 4$ is unbalanced.*

P r o o f. Let K_n where $n \geq 4$, be a complete graph with n vertices having a sum signed labeling. Every vertex of K_n is adjacent to every other vertex of the graph. Thus, there exists only one sum signed labeling of the graph. For $n = 3$, the number of negative edges in K_3 is 2 as given [7]. When $n \geq 4$, the minimum size of cycle present in K_n is that of 3. Consider a cycle between the vertices having the labels $n, n - 1$ and $n - 2$ and such a C_3 exists since all the vertices are adjacent. The product of signs of that cycle is negative, i.e., that cycle is unbalanced. In every K_n , $n \geq 4$ contains such a C_3 making the graph unbalanced. \square

Theorem 5. *For every graph that is neither a complete graph nor a tree there exists at least one sum signed labeling which is unbalanced.*

P r o o f. Let G be a connected graph which is neither complete nor a tree, with n vertices and m edges. Any sum signed labeling S of G will have $\sigma^-(G)$ and $\sigma_+(G)$ negative and positive edges respectively since they are the minimum in number. Thus, there exists $m - (\sigma^-(G) + \sigma_+(G))$ edges that can vary in signs. Accordingly, for each variation a sum signed graph is obtained which contains at least one cycle with odd number of negative edges making the graph unbalanced. \square

Figure 3 represents two distinct sum signed graphs of the underlying graph G . The solid line represents positive edge and dashed line represents negative edge. Clearly, the former is balanced and the latter is unbalanced.

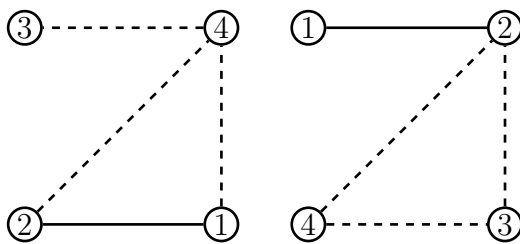

Figure 3. A graph with 4 vertices having two distinct sum signed labelling.

4. Algorithm for rna number of a tree

The concept of rna number in parity signed graphs was introduced in [2] and was studied in [3]. In [7], the rna number of sum signed graphs was introduced and has been found for various types of graphs. Here, the concept will be generalized in particular for acyclic graphs.

Consider a tree T with n vertices that has k pendant vertices. For finding the minimum number of negative edges in T , let T be drawn in such a way that the degrees of the vertices are increasing in each level by placing the pendant vertices in the lower level and the root in the upper level.

- Label the k pendant vertices v_1, v_2, \dots, v_k as $n, n-1, \dots, n-k-1$, respectively. Thus, the first level of vertices in tree is labeled.
- Except the vertex adjacent to v_1 labeled as n , mark the j adjacent vertices of v_2, v_3, \dots, v_k with $1, 2, \dots, j$. If any of the two pendant vertices have the same adjacent vertex v_i then, mark v_i with $\min\{1, 2, \dots, j\}$ which is not repeated. If v_1 is adjacent to a vertex which is adjacent to any other pendant vertex the, label it accordingly as mentioned previously. Otherwise, label the adjacent vertex to v_1 with the renewed $\min\{1, 2, \dots, j\}$ or $j+1$.
- Label the next level of l vertices with the minimum label from the set $\{1, 2, \dots, n\}$ which has not been repeated yet and also maintains the condition that the sum of the labels of the adjacent vertices never exceeds n .
- In a similar way, label all the remaining levels of the tree T .

Labeling a tree T in this way ensures that $\sigma^-(T) = 1$.

Pictorial representation of the algorithm is given in Fig. 4 for a tree with 23 vertices. In the figure, solid line represents positive edge and dashed line represents negative edge.

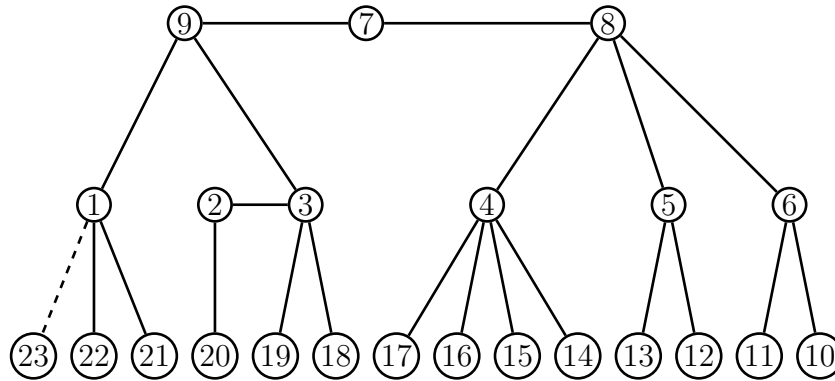

Figure 4. A tree with 23 vertices satisfying the above algorithm.

5. The *rna* complement number

The notion of *rna* number is mainly associated with that of negativity or negative people in a society. In contrast to that another number is introduced which deals with the minimization of positivity or positive people in a society. This number is known as *rna complement*.

Definition 3. The ‘*rna complement*’ number of a sum signed graph G is the minimum number of positive edges among all the sum signed labelings of G . It is denoted by $\sigma_+(G)$.

Theorem 6. For every tree T , $\sigma_+(T) = 0$.

Proceeding as in the algorithm for $\sigma_+(T)$ by changing the lowest labels to the highest ones and and vice versa, we have the result.

Theorem 7. For any graph G containing no pendant vertices, $\sigma_+(G) \geq 1$.

P r o o f. Consider a graph G with n vertices containing no pendant vertices. Assign the minimum label 1 to the vertex v_j with degree $\delta(G)$ so that minimum number of positive edges is obtained for the graph. Then, there exists at least $\delta(G) - 1$ positive edges. Since, G is a graph with no pendant vertices, $\delta(G) \geq 2$. Then, $\sigma_+(G) \geq \delta(G) - 1$ can be written as $\sigma_+(G) \geq 1$. \square

From the above observations, we can conclude the following theorem.

Theorem 8. For any graph G , $\sigma_+(G) < \sigma^-(G)$.

P r o o f. Let G be a graph with n number of vertices and let v_j be the vertex with degree $\delta(G)$. Let S_1 and S_2 be two sum signed graphs of G such that in S_1 , the vertex v_j with degree $\delta(G)$ is given the lowest label 1 and in S_2 , v_j is given the highest label n . Let the two graphs satisfy the condition that $|E^+(S_1)| > |E^-(S_2)|$. So, S_1 has the minimum number of negative edges as compared to S_2 and S_2 has the minimum number of positive edges as compared to S_1 . So,

$$|E^+(S_1)| = \delta(G) - 1 + k, \quad |E^-(S_2)| = \delta(G) + m,$$

where k and m are two positive integers. We need to minimise k and m such that $k \leq m$.

In S_1 , we need to minimise the number of positive edges, i.e., to maximise the number of negative edges. For this, we will exchange labels of any two vertices except v_j such that number of negative edges is maximised. Then,

$$|E^+(S_1)| = \delta(G) - 1 + k - a.$$

This process is continued for every vertex till the maximum number of negative edges is obtained in S_1 . Thus, $|E^+(S_1)| = \sigma_+(G)$. Similarly, we proceed with S_2 . After the process we will see that $|E^+(S_1)| \leq |E^-(S_2)|$.

The determination of rna and rna complement number is mainly depended on the assignment of maximum and minimum labels existing for the graph G to the vertex v_j . When these two labels, i.e., n and 1 are assigned to the vertex v_j in two different graphs S_3 and S_4 , it will be observed that in S_3 , there exists $\delta(G)$ negative edges for v_j and in S_4 and $\delta(G) - 1$ positive edges associated with the vertex v_j . This difference in the number of negative and positive edges goes on increasing as the labeling of the graph proceeds to find rna and $adhika$ number. Hence, it can be concluded that $\sigma_+(G) \neq \sigma^-(G)$. \square

Theorem 9. *The number of distinct signed graphs satisfying sum signed labeling for a connected graph G is at most $|E(G)| - \sigma^-(G) - \sigma_+(G)$.*

P r o o f. Let G be a connected graph with n vertices and m edges. Any sum signed labeling S of G will have $\sigma^-(G)$ and $\sigma_+(G)$ negative and positive edges since they are the minimum in number. Thus, there exist $m - (\sigma^-(G) + \sigma_+(G))$ edges which can vary in signs. For each variation in the sign of the edge, we will obtain a sum signed labeling of G which will be different from the previous ones. Hence, there exist at most $m - \sigma^-(G) - \sigma_+(G)$ distinct sum signed graphs for a graph G . \square

6. Conclusion

The recently introduced signed graphs open a wide variety of interesting problems in Graph Theory. In this paper, we have explored the balance nature, switching property, number of negative edges etc. of sum signed graph. The balanced nature of the sum signed graphs are studied using the concept of energy of signed graphs. An algorithm relating to the rna number of trees has been discussed. The concept of rna complement has been introduced and analyzed to some extent. There is enough scope for further studies. One such concept is that of energy of sum signed graphs and the other one is that of rna complement which has only been grazed.

REFERENCES

1. Acharya B.D. Spectral criterion for cycle balance in networks. *J. Graph Theory*, 1980. Vol. 4, No. 1. P. 1–11. DOI: [10.1002/jgt.3190040102](https://doi.org/10.1002/jgt.3190040102)
2. Acharya M., Kureethara J.V. *Parity Labeling in Signed Graphs*. 2021. 10 p. [arXiv:2012.07737v2](https://arxiv.org/abs/2012.07737v2) [math.CO]
3. Acharya M., Kureethara J.V., Zaslavsky T. Characterizations of some parity signed graphs. *Australas. J. Combin.*, 2021. Vol. 81. No. 1. P. 89–100.
4. Bhat M. A., Pirzada S. On equienergetic signed graphs. *Discrete Appl. Math.*, 2015. Vol. 189. P. 1–7. DOI: [10.1016/j.dam.2015.03.003](https://doi.org/10.1016/j.dam.2015.03.003)
5. Harary F. On the notion of balance of a signed graph. *Michigan Math. J.*, 1953/1954. Vol. 2, No. 2. P. 143–146. DOI: [10.1307/mmj/1028989917](https://doi.org/10.1307/mmj/1028989917)
6. Harary F. Structural duality. *Behavioural Sciences*, 1957. Vol. 2, No. 4. P. 255–265. DOI: [10.1002/bs.3830020403](https://doi.org/10.1002/bs.3830020403)
7. Ranjith A.P., Kureethara J.V. Sum signed graphs - I. *AIP Conf. Proc.*, 2020. Vol. 2261, No. 1. Art. no. 030047. DOI: [10.1063/5.0019053](https://doi.org/10.1063/5.0019053)
8. Sudev N. K., Germina K. A. A study on topological integer additive set-labeling of graphs. *Electron. J. Graph Theory Appl.*, 2015. Vol. 3, No. 1. P. 70–84. DOI: [10.5614/ejgta.2015.3.1.8](https://doi.org/10.5614/ejgta.2015.3.1.8)
9. Zaslavsky T. Signed graphs. *Discrete Appl. Math.*, 1982. Vol. 4, No. 1. P. 47–74. DOI: [10.1016/0166-218X\(82\)90033-6](https://doi.org/10.1016/0166-218X(82)90033-6)

LATTICE UNIVERSALITY OF LOCALLY FINITE p -GROUPS

Vladimir B. Repnitskiĭ

Ural Federal University,
19 Mira str., Ekaterinburg, 620002, Russian Federation

vladimir.repnitskii@urfu.ru

Abstract: For an arbitrary prime p , we prove that every algebraic lattice is isomorphic to a complete sublattice in the subgroup lattice of a suitable locally finite p -group. In particular, every lattice is embeddable in the subgroup lattice of a locally finite p -group.

Keywords: Subgroup lattice, Algebraic lattice, Complete sublattice, Lattice-universal class of algebras, Locally finite p -group, Group valuation.

1. Introduction and formulation of results

A lattice is called *algebraic* if it is complete and each element is a join of compact elements. Important examples of algebraic lattices include subalgebra lattices of universal algebras, particularly subgroup lattices of groups.

If a lattice L is complete and a subset M of L has the property that $\bigvee S, \bigwedge S \in M$ for every nonempty subset $S \subseteq M$, then M is called a *complete sublattice* of L . It is well known that a complete sublattice of an algebraic lattice is itself algebraic. This implies that complete sublattices of subgroup lattices are algebraic as well. Conversely, we proved in [7] that every algebraic lattice can be represented as a complete sublattice of the subgroup lattice of a suitable locally finite 2-group. It should be noted that every lattice can be embedded in some algebraic lattice, namely, in the lattice of its ideals. It follows that every lattice is embeddable in the subgroup lattice of a locally finite 2-group. For a given class K of algebras, we say that K is *lattice-universal* if every lattice is embeddable in the subalgebra lattice of some algebra from K . In this sense, the class of all locally finite 2-groups is lattice-universal. It must be said here that the lattice universality of the class of all groups was first proved by Whitman in [12]. Other examples of lattice-universal classes of algebras can be found in [3–5, 10].

The main theorem of the present paper generalizes the key result of the author's paper [7] from the case $p = 2$ to the case of an arbitrary prime number p .

Theorem 1. *For an arbitrary prime p , let K be an abstract class of groups satisfying the following conditions:*

- (1) K contains a group of order p ;
- (2) K is closed under restricted direct products, semidirect products and direct limits over totally ordered sets.

Then every algebraic lattice is isomorphic to a complete sublattice in the subgroup lattice of some group in K .

Since the class of all locally finite p -groups obviously satisfies conditions (1)–(2) of the theorem, from here we get the following corollary.

Corollary 1. *For an arbitrary prime p , every algebraic lattice is isomorphic to a complete sublattice in the subgroup lattice of a suitable locally finite p -group.*

As a consequence, we get the following statement.

Corollary 2. *For every prime p , the class of all locally finite p -groups is lattice-universal.*

The proof of Theorem 1 is given in the next section. Technically, it is based on the concept of so-called group valuations used by us in [7] when proving a specific case of this theorem for $p = 2$. Here we essentially apply the ideas and constructions of the mentioned paper.

Below we give some additional concepts and notation.

$\text{Sub } G$ is the subgroup lattice of a group G .

$\langle X \rangle$ is the subgroup generated by a subset X of a given group.

The commutator $[u, v]$ of elements u and v of a group means $u^{-1}v^{-1}uv$ and u^v means $v^{-1}uv$.

$\prod_{\lambda \in \Lambda} G_\lambda$ is the direct product of a set $\{G_\lambda \mid \lambda \in \Lambda\}$ of groups.

$\overline{\prod}_{\lambda \in \Lambda} G_\lambda$ is the restricted direct product of a set $\{G_\lambda \mid \lambda \in \Lambda\}$ of groups; this group is a subgroup of the corresponding direct product, and it can be regarded as the group of all functions from $\text{fun}(\Lambda, \bigcup_{\lambda \in \Lambda} G_\lambda)$ with the property $f(\lambda) \in G_\lambda$ and with finite supports.

For given groups G and T , let us consider the direct product $\prod_{h \in T} G^h$ of isomorphic copies G^h of the group G ; here $G^1 = G$. This group is regarded as the group $\text{fun}(T, G)$ of all functions from T to G and is denoted by G^T . The group T naturally acts on the group G^T in the following way: $f^t(h) = f(th)$ for all $f \in G^T$ and $t \in T$. With respect to this action, one can consider the semidirect product $T \ltimes G^T$, which is denoted by $G \wr T$ and is called the *wreath product* of the group G by the group T . Here, for $t_1, t_2 \in T$ and $f_1, f_2 \in G^T$, we have

$$(t_1, f_1) \cdot (t_2, f_2) = (t_1 t_2, f_1^{t_2} f_2).$$

For a prime p , the group

$$\langle u, v \mid u^p = v^p = [u, v]^p = 1, [u, [u, v]] = [v, [u, v]] = 1 \rangle$$

is of the order p^3 and is isomorphic to the multiplicative *unitriangular group of matrices* of order 3 over the field of order p . So it will be denoted by $\text{UT}_3(p)$. Here the generating elements u and v correspond to the matrices

$$\begin{pmatrix} 1 & 1 & 0 \\ 0 & 1 & 0 \\ 0 & 0 & 1 \end{pmatrix} \quad \text{and} \quad \begin{pmatrix} 1 & 0 & 0 \\ 0 & 1 & 1 \\ 0 & 0 & 1 \end{pmatrix},$$

respectively. For $p = 2$, this group is isomorphic to the 8-element *dihedral group*

$$\mathbb{D}_4 = \langle u, v \mid u^2 = v^2 = (uv)^4 = 1 \rangle.$$

Obviously, we have

$$\text{UT}_3(p) \cong \langle u \rangle \ltimes \langle v, [u, v] \rangle,$$

where the group $\langle u \rangle$ acts by conjugation on the normal subgroup $\langle v, [u, v] \rangle$ in $\text{UT}_3(p)$ and

$$\langle v, [u, v] \rangle \cong \langle v \rangle \times \langle [u, v] \rangle.$$

$J(P)$ is the *ideal lattice* of a given \vee -semilattice P with zero. Recall that every algebraic lattice is isomorphic to the ideal lattice $J(P)$ of its \vee -semilattice P of compact elements.

The other definitions and notations used but undefined in the paper can be found in the books [1, 2, 9].

2. Concept of group valuation and the proof of the theorem

Let us give a key notion of the present paper. It was introduced by the author in [6] (see also [7, 8, 11]).

Definition 1. Let P be a \vee -semilattice with zero. For a group G , we call a mapping $\delta: G \rightarrow P$ a **group valuation** if the following conditions hold:

- (1) $\delta(1) = 0$;
- (2) $\delta(g^{-1}) = \delta(g)$ for every $g \in G$;
- (3) $\delta(g_1g_2) \leq \delta(g_1) \vee \delta(g_2)$ for every $g_1, g_2 \in G$.

For an arbitrary ideal $I \in \mathbf{J}(P)$ and $a \in P$, let us put $O_\delta(I) = \delta^{-1}(I)$ and $O_\delta(a) = O_\delta(a\downarrow)$, where $a\downarrow$ denotes the principal ideal generated by the element a . Obviously, $O_\delta(I)$ is a subgroup of G and $O_\delta(I) = \bigvee_{a \in I} O_\delta(a)$.

The following simple proposition explains the role of the notion of group valuation in our examination (see its proof, for example, in [7]).

Proposition 1. Let a valuation $\delta: G \rightarrow P$ satisfy the following conditions:

- (1) for every $a, b \in P$ and $g \in G$, $\delta(g) \leq a \vee b$ implies $g \in \langle O_\delta(a), O_\delta(b) \rangle$;
- (2) δ is a surjective mapping of G onto P .

Then the mapping $O_\delta: \mathbf{J}(P) \rightarrow \text{Sub } G$ is a complete embedding of the ideal lattice $\mathbf{J}(P)$ in the subgroup lattice $\text{Sub } G$, and so the lattice $\mathbf{J}(P)$ is isomorphic to a complete sublattice of the corresponding subgroup lattice.

For groups G, G' and their valuations $\delta: G \rightarrow P, \delta': G' \rightarrow P$, we say that the pair (G', δ') is an *extension* of the pair (G, δ) if G is a subgroup of G' and $\delta'|_G = \delta$.

The following statement is key in proving our theorem.

Proposition 2. Let G be a group and $\delta: G \rightarrow P$ a group valuation. Then, for arbitrary elements $a, b \in P$, there exists an extension (G', δ') of the pair (G, δ) such that, if $\delta(g) \leq a \vee b$ for an element $g \in G$, then in the group G' the membership $g \in \langle O_{\delta'}(a), O_{\delta'}(b) \rangle$ holds; moreover, for an arbitrary prime p , one may take the group $G \wr \text{UT}_3(p)$ as G' .

This statement was proved in [7] for $p = 2$, and in this case the role of the group $\text{UT}_3(p)$ was played by the dihedral group \mathbb{D}_4 isomorphic to $\text{UT}_3(2)$.

We will prove Proposition 2 at the end of the section. But now we will explain how the theorem is derived from it. This derivation practically iterates a similar derivation for $p = 2$ in our paper [7], but we will give it for the reader's convenience.

Let L be an arbitrary algebraic lattice and P its \vee -semilattice of compact elements. Thus, we have $L \cong \mathbf{J}(P)$. Let p be an arbitrary prime number and K an abstract class of groups satisfying conditions (1)–(2) of the Theorem 1. Now consider the set $\{\langle w_a \rangle \mid a \in P\}$ of groups of order p generated by the elements w_a indexed by elements from P . Let

$$G^* = \overline{\prod_{a \in P} \langle w_a \rangle}$$

be the corresponding restricted direct product of these groups. Then $G^* \in K$ and each non-identity element from G^* can be uniquely represented (up to the permutation of the factors) as a term of

the form $w_{a_1}^{\epsilon_1} w_{a_2}^{\epsilon_2} \cdots w_{a_n}^{\epsilon_n}$ (here $n \geq 1$, $w_{a_i} \neq w_{a_j}$ for $i \neq j$ and $1 \leq \epsilon_i \leq p-1$). Now we define a mapping $\delta^* : G^* \rightarrow P$ by the following rule: $\delta^*(1) = 0$ and, if $g = w_{a_1}^{\epsilon_1} w_{a_2}^{\epsilon_2} \cdots w_{a_n}^{\epsilon_n}$, then $\delta^*(g) = a_1 \vee a_2 \vee \cdots \vee a_n$. It is easy to see that the mapping δ^* is a group valuation.

Now let

$$\{(a_\gamma, b_\gamma) \in P \times P \mid 0 < \gamma < \chi\}$$

be the well-ordered set of all couples from P^2 . We define by induction on γ a set

$$\{G_\gamma \mid 0 \leq \gamma < \chi\}$$

of groups from K and a set

$$\{\delta_\gamma \mid 0 \leq \gamma < \chi\}$$

of group valuations $\delta_\gamma : G_\gamma \rightarrow P$ in the following way.

Put $G_0 = G^*$ and $\delta_0 = \delta^*$. If the ordinal $\gamma > 0$ is not limit, then the pair $(G_\gamma, \delta_\gamma)$ is an extension of the pair $(G_{\gamma-1}, \delta_{\gamma-1})$ with the property $g \in \langle O_{\delta_\gamma}(a_\gamma), O_{\delta_\gamma}(b_\gamma) \rangle$ in G_γ for every $g \in G^*$ satisfying the condition $\delta_{\gamma-1}(g) = \delta^*(g) \leq a_\gamma \vee b_\gamma$. Such an extension exists by Proposition 2, and in this case $G_\gamma = G_{\gamma-1} \wr \mathbb{U}\mathbb{T}_3(p)$. If the ordinal γ is limit, then put

$$G_\gamma = \bigcup (G_\zeta \mid \zeta < \gamma) \quad \text{and} \quad \delta_\gamma = \bigcup (\delta_\zeta \mid \zeta < \gamma).$$

Further, put

$$G^{(1)} = \bigcup (G_\gamma \mid \gamma < \chi) \quad \text{and} \quad \delta^{(1)} = \bigcup (\delta_\gamma \mid \gamma < \chi).$$

By construction, the mapping $\delta^{(1)} : G^{(1)} \rightarrow P$ is a valuation and the pair $(G^{(1)}, \delta^{(1)})$ is an extension of the pair (G^*, δ^*) such that, for any elements $g \in G^*$ and $a, b \in P$ with $\delta^*(g) \leq a \vee b$, the membership $g \in \langle O_{\delta^{(1)}(a)}, O_{\delta^{(1)}(b)} \rangle$ holds in $G^{(1)}$. In addition, we have $\mathbb{U}\mathbb{T}_3(p) \in K$, since K contains all p -element groups and, by condition (2) of the theorem, is closed under direct and semidirect products of any two of its groups and $\mathbb{U}\mathbb{T}_3(p)$ as mentioned above is a semidirect product of the p -element group $\langle u \rangle$ with the direct product of the p -element groups $\langle v \rangle$ and $\langle [u, v] \rangle$. Therefore, $G^{(1)} \in K$ because, by the same condition, the class K is closed also under direct limits over totally ordered sets.

Next we construct the following increasing under inclusion chains of groups $G^{(n)} \in K$ and valuations $\delta^{(n)} : G^{(n)} \rightarrow P$ ($n \in \mathbb{N}$):

$$G^* = G^{(0)} \subset G^{(1)} \subset G^{(2)} \subset \dots, \quad \delta^* = \delta^{(0)} \subset \delta^{(1)} \subset \delta^{(2)} \subset \dots$$

such that, for every $n > 1$, $\delta^{(n)}|_{G^{(n-1)}} = \delta^{(n-1)}$ and, for every $g \in G^{(n-1)}$ and $a, b \in P$, if $\delta^{(n-1)}(g) \leq a \vee b$, then $g \in \langle O_{\delta^{(n)}(a)}, O_{\delta^{(n)}(b)} \rangle$ in $G^{(n)}$; here the pair $(G^{(n)}, \delta^{(n)})$ is constructed from the pair $(G^{(n-1)}, \delta^{(n-1)})$ as it was done in the first step corresponding to $n = 1$.

Put

$$G = \bigcup (G^{(n)} \mid n \in \mathbb{N}) \quad \text{and} \quad \delta = \bigcup (\delta^{(n)} \mid n \in \mathbb{N}).$$

Then, by construction, we have $G \in K$ and the mapping $\delta : G \rightarrow P$ is a valuation with the property: for all $g \in G$ and $a, b \in P$, the inequality $\delta(g) \leq a \vee b$ implies $g \in \langle O_\delta(a), O_\delta(b) \rangle$, i.e., δ satisfies condition (1) of Proposition 1. In addition, δ^* is surjective and $\delta|_{G^*} = \delta^*$, whence we deduce that the valuation δ is surjective as well, i.e., it satisfies condition (2) of Proposition 1. Therefore, by this proposition, there exists a complete embedding of the ideal lattice $J(P)$ in the subgroup lattice $\text{Sub}G$ of the constructed group $G \in K$. This means that the algebraic lattice L , for which P is the \vee -semilattice of compact elements, is isomorphic to a complete sublattice of $\text{Sub}G$. The derivation is over. \square

The following two constructions of the semidirect product and direct product of group valuations were introduced by the author in [7].

If a group T acts on a group H , and if $\hat{\delta}: T \rightarrow P$ and $\tilde{\delta}: H \rightarrow P$ are group valuations such that

$$\tilde{\delta}(h^t) \leq \hat{\delta}(t) \vee \tilde{\delta}(h)$$

for any $h \in H$ and $t \in T$, then the mapping $\hat{\delta} \times \tilde{\delta}: T \times H \rightarrow P$ defined by

$$(\hat{\delta} \times \tilde{\delta})(t, h) = \hat{\delta}(t) \vee \tilde{\delta}(h)$$

is evidently a group valuation. It extends both $\tilde{\delta}: H \rightarrow P$ and $\hat{\delta}: T \rightarrow P$ under the canonical isomorphic embeddings $h \mapsto (1, h)$ and $t \mapsto (t, 1)$ of H and T respectively into $T \times H$. Thus the pair $(T \times H, \hat{\delta} \times \tilde{\delta})$ is an extension both of the pair $(H, \tilde{\delta})$ and of the pair $(T, \hat{\delta})$.

Definition 2. *The valuation $\hat{\delta} \times \tilde{\delta}$ is called the **semidirect product of $\hat{\delta}$ and $\tilde{\delta}$** .*

Definition 3. *If $\delta_i: G_i \rightarrow P$, $i = 1, \dots, n$, are group valuations, then the mapping $\delta_1 \times \dots \times \delta_n: G_1 \times \dots \times G_n \rightarrow P$ defined by*

$$(\delta_1 \times \dots \times \delta_n)(g_1, \dots, g_n) = \delta_1(g_1) \vee \dots \vee \delta_n(g_n)$$

*is evidently a group valuation extending each δ_i under the canonical embedding of G_i into $G_1 \times \dots \times G_n$. It is called the **direct product of the valuations δ_i 's**.*

Let G be a group, $\delta: G \rightarrow P$ be a valuation, and let $a, b \in G$. Consider the group

$$\mathbb{UT}_3(p) = \langle u, v \mid u^p = v^p = [u, v]^p = 1, [u, [u, v]] = [v, [u, v]] = 1 \rangle.$$

Each of its elements can be uniquely written in the form $u^\alpha v^\beta [u, v]^\gamma$, where $\alpha, \beta, \gamma \in \{0, 1, \dots, p-1\}$. It is easy to check that the product of two such terms is

$$u^{\alpha_1} v^{\beta_1} [u, v]^{\gamma_1} \cdot u^{\alpha_2} v^{\beta_2} [u, v]^{\gamma_2} = u^{\alpha_1 + \alpha_2} v^{\beta_1 + \beta_2} [u, v]^{\gamma_1 + \gamma_2 - \beta_1 \alpha_2},$$

where exponents are added and multiplied modulo p .

Now we define a mapping $\hat{\delta}: \mathbb{UT}_3(p) \rightarrow P$ by the rule:

$$\begin{aligned} \hat{\delta}(1) &= 0, & \hat{\delta}(u^\alpha) &= a \quad \text{if } 1 \leq \alpha \leq p-1, & \hat{\delta}(v^\beta) &= b \quad \text{if } 1 \leq \beta \leq p-1, \\ \hat{\delta}(t) &= a \vee b & \text{for all other } t & \in \mathbb{UT}_3(p). \end{aligned}$$

It is easy to see that the mapping $\hat{\delta}$ is a group valuation.

Next we construct an extension $\delta': G \wr \mathbb{UT}_3(p) \rightarrow P$ of a group valuation δ desired in Proposition 2 from the group valuation $\hat{\delta}: \mathbb{UT}_3(p) \rightarrow P$ and from an additional valuation $\tilde{\delta}: G^{\mathbb{UT}_3(p)} \rightarrow P$. The valuation $\tilde{\delta}$ will be the direct product (see Definition 3) of group valuations $\delta_t: G \rightarrow P$ defined below for every $t \in \mathbb{UT}_3(p)$. Their constructions generalize the corresponding constructions for $p = 2$ given in [7].

We set $\delta_t(1) = 0$ for any $t \in \mathbb{UT}_3(p)$. For a non-identity element $g \in G$, we set

- (1) $\delta_1(g) = \delta(g)$,
- (2) $\delta_{u^\alpha}(g) = a \vee \delta(g) \quad \text{if } 1 \leq \alpha \leq p-1$,
- (3) $\delta_{v^\beta}(g) = b \vee \delta(g) \quad \text{if } 1 \leq \beta \leq p-1$,

$$(4) \delta_{[u,v]^\gamma}(g) = \begin{cases} 0 & \text{if } \delta(g) \leq a \vee b, \\ a \vee b \vee \delta(g) & \text{otherwise} \end{cases} \quad \text{if } 1 \leq \gamma \leq p-1,$$

$$(5) \delta_{u^\alpha [u,v]^\gamma}(g) = \begin{cases} a & \text{if } \delta(g) \leq a \vee b, \\ a \vee b \vee \delta(g) & \text{otherwise} \end{cases} \quad \text{if } 1 \leq \alpha \leq p-1 \quad \text{and} \quad 1 \leq \gamma \leq p-1,$$

$$(6) \delta_{v^\beta [u,v]^\gamma}(g) = \begin{cases} b & \text{if } \delta(g) \leq a \vee b, \\ a \vee b \vee \delta(g) & \text{otherwise} \end{cases} \quad \text{if } 1 \leq \beta \leq p-1 \quad \text{and} \quad 1 \leq \gamma \leq p-1,$$

$$(7) \delta_{u^\alpha v^\beta [u,v]^\gamma}(g) = a \vee b \vee \delta(g) \quad \text{if } 1 \leq \alpha \leq p-1, \quad 1 \leq \beta \leq p-1 \quad \text{and} \quad 0 \leq \gamma \leq p-1.$$

Checking that δ_t is a group valuation for every $t \in \mathbb{UT}_3(p)$ is very simple and completely identical to checking a similar statement in [7].

Lemma 1. *For any $w, t \in \mathbb{UT}_3(p)$ and $g \in G$, the inequality $\delta_{tw}(g) \leq \hat{\delta}(t) \vee \delta_w(g)$ holds.*

P r o o f. From the definitions of the group valuations δ_t , it directly follows that the equality $a \vee b \vee \delta_w(g) = a \vee b \vee \delta(g)$ holds for every $w \in \mathbb{UT}_3(p)$ and $g \in G$. Therefore, if $\hat{\delta}(t) = a \vee b$, then we have

$$\delta_{tw}(g) \leq a \vee b \vee \delta(g) = a \vee b \vee \delta_w(g) = \hat{\delta}(t) \vee \delta_w(g).$$

The case $\hat{\delta}(t) \neq a \vee b$ is true only if

$$t \in \{1, u^\alpha, v^\beta \mid 1 \leq \alpha \leq p-1, 1 \leq \beta \leq p-1\}.$$

In the case $t = 1$ the inequality $\delta_{tw}(g) \leq \hat{\delta}(t) \vee \delta_w(g)$ is evident.

Let $t = u^\alpha$, where $1 \leq \alpha \leq p-1$. Then $\hat{\delta}(t) = a$. Here, if $b \leq \delta_w(g)$, then again

$$\delta_{tw}(g) \leq a \vee b \vee \delta(g) = a \vee b \vee \delta_w(g) = \hat{\delta}(t) \vee \delta_w(g).$$

If $b \not\leq \delta_w(g)$, then the following four cases are possible:

- (1) $w = 1$,
- (2) $w = u^{\alpha'}$, where $1 \leq \alpha' \leq p-1$ and $\delta_w(g) = a \vee \delta(g)$,
- (3) $w = [u, v]^\gamma$, where $1 \leq \gamma \leq p-1$, $\delta(g) \leq a \vee b$ and $\delta_w(g) = 0$,
- (4) $w = u^{\alpha'} [u, v]^\gamma$, where $1 \leq \alpha' \leq p-1$, $1 \leq \gamma \leq p-1$, $\delta(g) \leq a \vee b$ and $\delta_w(g) = a$.

In case (1), we have $\delta_{tw}(g) = \delta_{u^\alpha}(g) = a \vee \delta(g) = a \vee \delta_1(g) = \hat{\delta}(t) \vee \delta_w(g)$.

In case (2), we have $\delta_{tw}(g) = \delta_{u^{\alpha+\alpha'}}(g) \leq a \vee \delta(g) = a \vee \delta_w(g) = \hat{\delta}(t) \vee \delta_w(g)$.

In case (3), we have $\delta_{tw}(g) = \delta_{u^\alpha [u,v]^\gamma}(g) = a \leq a \vee \delta_w(g) = \hat{\delta}(t) \vee \delta_w(g)$.

In case (4), we have $\delta_{tw}(g) = \delta_{u^{\alpha+\alpha'} [u,v]^\gamma}(g) \leq a = \hat{\delta}(t) \vee \delta_w(g)$.

The case $t = v^\beta$, where $1 \leq \beta \leq p-1$, is symmetric to the previous one and can be checked by a parallel argument. \square

Next, as noted above, we set $\tilde{\delta}: G^{\mathbb{UT}_3(p)} \rightarrow P$ as the direct product of the valuations δ_t , $t \in \mathbb{UT}_3(p)$. This is a group valuation extending $\delta_1 = \delta$ and

$$\tilde{\delta}(f) = \bigvee_{t \in \mathbb{UT}_3(p)} \delta_t(f(t))$$

for any $f: \mathbb{UT}_3(p) \rightarrow G$.

We then define $\delta': G \wr \mathbb{UT}_3(p) \rightarrow P$ as the semidirect product of $\hat{\delta}: \mathbb{UT}_3(p) \rightarrow P$ and $\tilde{\delta}: G^{\mathbb{UT}_3(p)} \rightarrow P$ (see Definition 2). This is an extension of $\tilde{\delta}$, hence also of δ . To prove that the semidirect product $\delta' = \hat{\delta} \ltimes \tilde{\delta}$ is indeed a group valuation, we have to check that

$$\tilde{\delta}(f^t) \leq \hat{\delta}(t) \vee \tilde{\delta}(f)$$

for any $f \in G^{\mathbb{UT}_3(p)}$ and $t \in \mathbb{UT}_3(p)$. But this is easily accomplished using Lemma 1:

$$\begin{aligned} \tilde{\delta}(f^t) &= \bigvee_{w \in \mathbb{UT}_3(p)} \delta_w(f^t(w)) = \bigvee_{w \in \mathbb{UT}_3(p)} \delta_w(f(tw)) = \bigvee_{t^{-1}w \in \mathbb{UT}_3(p)} \delta_{t^{-1}w}(f(tt^{-1}w)) \\ &= \bigvee_{t^{-1}w \in \mathbb{UT}_3(p)} \delta_{t^{-1}w}(f(w)) \leq \bigvee_{t^{-1}w \in \mathbb{UT}_3(p)} \left(\hat{\delta}(t^{-1}) \vee \delta_w(f(w)) \right) \\ &= \hat{\delta}(t^{-1}) \vee \left(\bigvee_{t^{-1}w \in \mathbb{UT}_3(p)} \delta_w(f(w)) \right) = \hat{\delta}(t) \vee \left(\bigvee_{w \in \mathbb{UT}_3(p)} \delta_w(f(w)) \right) \\ &= \hat{\delta}(t) \vee \tilde{\delta}(f). \end{aligned}$$

Thus, we proved that the mapping $\delta': G \wr \mathbb{UT}_3(p) \rightarrow P$ is a group valuation and the pair $(G \wr \mathbb{UT}_3(p), \delta')$ is an extension of the pair (G, δ) . Now it remains to note that this extension has the required property, i.e., if $\delta(g) \leq a \vee b$ for an element $g \in G$, then, in the group $G \wr \mathbb{UT}_3(p)$, the membership $g \in \langle O_{\delta'}(a), O_{\delta'}(b) \rangle$ holds. Indeed, by construction, $\delta'(u) = \hat{\delta}(u) = a$ and $\delta'(v) = \hat{\delta}(v) = b$. In addition, the element $g \in G$ as an element of the group $G \wr \mathbb{UT}_3(p)$ means a function

$$f(w) \in G^{\mathbb{UT}_3(p)}$$

such that

$$f(w) = \begin{cases} g, & \text{if } w = 1, \\ 1, & \text{if } w \neq 1. \end{cases}$$

Therefore, for an arbitrary $t \in \mathbb{UT}_3(p)$, we have $g^t = f^t(w) = f(tw)$ and

$$\begin{aligned} \delta'(g^t) &= \tilde{\delta}(f^t) = \bigvee_{w \in \mathbb{UT}_3(p)} \delta_w(f^t(w)) = \bigvee_{w \in \mathbb{UT}_3(p)} \delta_w(f(tw)) \\ &= \delta_{t^{-1}}(f(1)) \vee \left(\bigvee_{w \neq t^{-1}} \delta_w(f(tw)) \right) = \delta_{t^{-1}}(g) \vee \left(\bigvee_{w \neq t^{-1}} \delta_w(1) \right) = \delta_{t^{-1}}(g). \end{aligned}$$

From here we obtain that $\delta'(g^{[v,u]}) = \delta_{[u,v]}(g) = 0$ for every element $g \in G$ such that $\delta(g) \leq a \vee b$. This implies that

$$g = [v, u] \cdot g^{[v,u]} \cdot [u, v] \in \langle O_{\delta'}(a), O_{\delta'}(b), O_{\delta'}(0) \rangle = \langle O_{\delta'}(a), O_{\delta'}(b) \rangle.$$

The proof of Proposition 2, and with it the Theorem 1, is complete. □

Acknowledgments

The author wishes to thank Mikhail Volkov and anonymous referees for their comments and kind help in preparing the final version of this paper.

REFERENCES

1. Grätzer G. *General Lattice Theory, 2nd edn.* Basel: Birkhäuser–Verlag, 2003. XX+663 pp.
2. Kargapolov M. I., Merzljakov Ju. I. *Fundamentals of the Theory of Groups.* Translated from the second Russian edition by Robert G. Burns. Grad. Texts in Math., vol. 62. New York–Berlin: Springer–Verlag, 1979. XVIII+203 pp.
3. Repnitskiĭ V. B. On the representation of lattices by lattices of subsemigroups. *Russian Math. (Iz. VUZ)*, 1996. Vol. 40, No. 1. P. 55–64.
4. Repnitskiĭ V. B. Lattice universality of free Burnside groups. *Algebra and Logic*, 1996. Vol. 35. P. 330–343. DOI: [10.1007/BF02367358](https://doi.org/10.1007/BF02367358)
5. Repnitskiĭ V. B. On lattice-universal varieties of algebras. *Russian Math. (Iz. VUZ)*, 1997. Vol. 41, No. 5. P. 50–56.
6. Repnitskiĭ V. B. A new proof of Tůma’s theorem on intervals in subgroup lattices. In: *Contrib. General Algebra 16. Proc. 68th Workshop on General Algebra “68. Arbeitstagung Allgemeine Algebra”, Dresden, Germany, June 10–13, 2004 and Summer School 2004 on General Algebra and Ordered Sets, Malá Morávka, Czech Republic, September 5–11, 2004.* Chajda I. et al. (eds.). Klagenfurt: Verlag Johannes Heyn, 2005. P. 213–230.
7. Repnitskiĭ V. B. Lattice universality of locally finite 2-groups. *Algebra Univers.*, 2020. Vol. 81. Art. no. 44. DOI: [10.1007/s00012-020-00672-8](https://doi.org/10.1007/s00012-020-00672-8)
8. Repnitskiĭ V., Tůma J. Intervals in subgroup lattices of countable locally finite groups. *Algebra Univers.*, 2008. Vol. 59, P. 49–71. DOI: [10.1007/s00012-008-2045-5](https://doi.org/10.1007/s00012-008-2045-5)
9. Schmidt R. *Subgroup Lattices of Groups.* De Gruyter Expositions in Mathematics, vol. 14. Berlin–New York: Walter de Gruyter, 1994. XVI+572 pp. DOI: [10.1515/9783110868647](https://doi.org/10.1515/9783110868647)
10. Shevrin L. N., Ovsyannikov A. J. *Semigroups and Their Subsemigroup Lattices.* Ser. Math. Appl. Dordrecht: Kluwer Academic Publishers, 1996. XI+380 pp.
11. Tůma J. Semilattice-valued measures. In: *Contrib. General Algebra 18, Proc. 73rd Workshop on General Algebra 2007 (AAA 73) and 22nd Conf. Young Algebraists.* Klagenfurt: Verlag Johannes Heyn, 2008. P. 199–210.
12. Whitman Ph. M. Lattices, equivalence relations, and subgroups. *Bull. Amer. Math. Soc.*, 1946. Vol. 52. P. 507–522. DOI: [10.1090/S0002-9904-1946-08602-4](https://doi.org/10.1090/S0002-9904-1946-08602-4)

FIXED RATIO POLYNOMIAL TIME APPROXIMATION ALGORITHM FOR THE PRIZE-COLLECTING ASYMMETRIC TRAVELING SALESMAN PROBLEM¹

Ksenia Rizhenko[†], Katherine Neznakhina^{††}, Michael Khachay^{†††}

Krasovskii Institute of Mathematics and Mechanics,
Ural Branch of the Russian Academy of Sciences,
16 S. Kovalevskaya Str., Ekaterinburg, 620108, Russian Federation

[†]kseniarizhenko@gmail.com ^{††}eneznakhina@yandex.ru ^{†††}mkhachay@imm.uran.ru

Abstract: We develop the first fixed-ratio approximation algorithm for the well-known Prize-Collecting Asymmetric Traveling Salesman Problem, which has numerous valuable applications in operations research. An instance of this problem is given by a complete node- and edge-weighted digraph G . Each node of the graph G can either be visited by the resulting route or skipped, for some penalty, while the arcs of G are weighted by non-negative transportation costs that fulfill the triangle inequality constraint. The goal is to find a closed walk that minimizes the total transportation costs augmented by the accumulated penalties. We show that an arbitrary α -approximation algorithm for the Asymmetric Traveling Salesman Problem induces an $(\alpha + 1)$ -approximation for the problem in question. In particular, using the recent $(22 + \varepsilon)$ -approximation algorithm of V. Traub and J. Vygen that improves the seminal result of O. Svensson, J. Tarnavski, and L. Végh, we obtain $(23 + \varepsilon)$ -approximate solutions for the problem.

Keywords: Prize-Collecting Traveling Salesman Problem, Triangle inequality, Approximation algorithm, Fixed approximation ratio.

1. Introduction

The Prize-Collecting Traveling Salesman Problem (PCTSP) is of the most recognized problems of combinatorial optimization. Introduced by Egon Balas in [2], it has valuable applications in drone routing [10], ride-sharing [23], or metal production. Theoretically, the PCTSP is closely related to the well-known Traveling Salesman Problem (TSP) [17] and Orienteering Problem (OP) [30].

Following to [2], an informal statement of the PCTSP is to find a traveling plan across a given transportation network, which consists of *cities* and *roads*. This network is represented by some connected graph.

For each city, the salesperson gains a reward or pays a penalty depending on whether he or she visits this city or not. In addition, traveling on an arbitrary road is charged with an appropriate transportation cost.

The goal is to find a tour retaining at least the given amount of reward and having the smallest accumulated costs and penalties.

1.1. Related work

Since PCTSP embeds the classic Traveling Salesman Problem, its general setting is strongly NP-hard and hard to approximate [27]. Furthermore, the problem remains intractable even in very

¹This research was carried out under the financial support of the RSF, grant no. 22-21-00672, <https://rscf.ru/project/22-21-00672/>.

specific settings, e.g. on the Euclidean plane [25]. As for the majority of known combinatorial problems, algorithmic desingn of this problem develops in the following main directions.

The first direction is related to exact branch-and-bound-and-cut algorithms [5, 11, 12] and goes back to fundamental results by E. Balas and M. Fischetti and P. Toth that describe facet-inducing inequalities for the equivalent mixed-integer linear programs [2, 15], see also [20]. Despite the significant impact contributed by these polyhedral results to the theory of combinatorial optimization and notable recent success in hardware development, exact algorithms still remain applicable to rather small instances of the problem.

The second one deals with developing problem-specific versions of various heuristics and meta-heuristics including variable neighborhood search [21], tabu search [26], simulated annealing [14], bio-inspired and genetic algorithms [13], and their combinations. Often heuristics demonstrate an amazing performance by finding optimal (or close-to-optimal) solutions in a few seconds for real-life instances that come from industrial applications. Unfortunately, an absence of theoretical guarantees entails experimental assessment of these algorithms and possible additional tuning of their external parameters in case of any novel modification of the problem or series of instances.

Finally, the third direction relates to approximation algorithms augmented by theoretical performance guarantees and polynomial (or quasipolynomial) time approximation schemes (PTAS and QPTAS, respectively). First, we should mention the famous $5/2$ -approximation algorithm by D. Bienstock, M. Goemans, D. Simchi-Levi, and D. Williamson [6] for for the metric PCTSP. These algorithm relies on the classic L.Lovász result for the Euclidean graphs, an original technique of LP-relaxation rounding, and exploit as a black box the classic Christofides $3/2$ -approximation algorithm [9] for the metric TSP. Further, incorporation of the classic primal-dual approach by M.Goemans and D.Williamson [16] leads to several improvements of this result including $(1 - 2/3e^{-1/3})^{-1}$ -approximation algorithm and more recent $(2 - \varepsilon)$ -approximation algorithm [1].

We should notice that fixed-ratio approximation appears to be the best approximation result that can be obtained for an arbitrary metric (unless $P=NP$) since the metric PCTSP is APX-hard. Nevertheless, for some metrics of a special kind, there exist much more promising results, including PTAS for the PCTSP formulated on planar graphs [4] and the PCTSP in doubling metrics [7]. The latter PTAS is based on the breakthrough result obtained by Y. Bartal, L.A. Gottlieb, and R. Krauthgamer [3] for the classic TSP and continued by the series of recent papers (see, e.g. [8, 19]), where the efficient approximation of the combinatorial optimization problems is managed to extend beyond the finite dimensional vector spaces.

All the aforementioned results were obtained for the symmetric version of the problem. Mean-time, approximation of its asymmetric version known as the Prize-Collecting Asymmetric Traveling Salesman Problem (PCATSP) still remains weakly studied. To the best of our knowledge, $(1 + \lceil \log n \rceil)$ -approximation algorithm proposed in [24] is the only result obtained in this field so far. In this paper, we try to bridge this gap.

1.2. Our contribution

For the PCATSP with the triangle inequality, we introduce the first fixed-ratio polynomial time algorithm, which finds $(23 + \varepsilon)$ -approximate solution of the problem for and arbitrary $\varepsilon > 0$. Our approach appears to be a further extension of the classic splitting-of technique for the Eulerian graphs and rounding framework of [6], and exploit the seminal recent Svensson-Traub $(22 + \varepsilon)$ -approximation algorithm for the Asymmetric Traveling Salesman Problem (ATSP) with the triangle inequality, as a main building block.

In Section 2, we give a formulation of the problem in question. Next, in Section 3, we recall the necessary definitions and notation. Section 4 opens the discussion of novel results. In this section, we introduce the proposed algorithm, whose approximation ratio and running time bounds

are proved in Section 5. Finally, in Section 6, we summarize the obtained results and discuss some open questions.

2. Problem statement

In this paper, we study polynomial approximation of the Profitable Tour Problem (PTP), introduced by M. Dell'Amico, F. Maffioli, and P. Värbrand in [12], which is a simplified version of the PCATSP introduced by E. Balas in [2]. An arbitrary PTP instance is given by a complete digraph $G = (V, A)$ augmented by an edge-weighting function $c: A \rightarrow \mathbb{R}_+$ that specifies transportation costs and fulfills the triangle inequality

$$c(u, v) + c(v, w) \geq c(u, w) \quad \text{for any } \{u, v, w\} \subset V, \quad (2.1)$$

and node-weighting function $\pi: V \rightarrow \mathbb{R}_+$, defining the penalties for skipping nodes of the graph G . Unlike the classic Asymmetric Traveling Salesman Problem, feasible solution set of the PTP contains an arbitrary closed walk (including the *empty* tour that skips each node of the graph G). The problem is to find the minimum cost walk, where a cost of an arbitrary walk T is defined as follows:

$$\text{cost}(T) = \sum_{a \in T} c_a + \sum_{v \notin T} \pi_v,$$

provided T visits some subset $W \subset V$.

Comparing the considered problem with the original one introduced in [2], we should mention that, similarly to [6]

- (i) we assume that transportation costs satisfy the triangle inequality (2.1),
- (ii) visiting of an arbitrary node of the graph G has no additional profit,
- (iii) as a consequence, we exclude the knapsack constraint that restricts minimum possible profit to collect.

3. Preliminaries

Results of this paper are mainly based on approximation algorithms proposed recently for the ATSP, where the edge-weighting function satisfies the triangle inequality, and on the well-known splitting-off property of the Eulerian graphs.

In the ATSP, we are given by a complete digraph $G = (V, A)$ and a weighting function $c: A \rightarrow \mathbb{R}_+$, which specifies transportation costs. Without loss of generality, we assume that c satisfies the triangle inequality. The goal is to construct a closed route that visits each node of the graph G (a tour) with the minimum transportation cost.

For our construction, another equivalent formulation of the ATSP appears to be more convenient. In this setting, we are required to find a minimum cost (multi-)subset $T \subset A$, such that (V, T) is Eulerian connected multigraph. Assuming that each arc a is contained in T with multiplicity x_a , the cost of T is defined by

$$c(T) = \sum_{a \in T} c_a x_a.$$

In this context, it is convenient to assume that each tour R is defined by its arc-multiplicity vector x .

In the following, we need some standard definitions and notation. As usual, by $\delta(U_1, U_2)$ we denote the set of arcs $\{(u, v) \in A: u \in U_1, v \in U_2\}$ for an arbitrary disjoint non-empty subsets

$U_1, U_2 \subset V$. In particular case, where $U_1 = W$ and $U_2 = V \setminus W$, $\delta(U_1, U_2)$ coincides with classic notation of outgoing and incoming cuts

$$\begin{aligned}\delta^+(W) &= \delta(W, V \setminus W) = \{(u, v) \in A : u \in W, v \notin W\} \quad \text{and} \\ \delta^-(W) &= \delta(V \setminus W, W) = \{(u, v) \in A : u \notin W, v \in W\},\end{aligned}$$

respectively and the cut $\delta(X) = \delta^+(X) \cup \delta^-(X)$. Next, we use a short notation $\delta(v)$ for $X = \{v\}$.

Further, we use the classic Held-Karp Mixed Integer Linear (MILP)-model for the ATSP

$$\min \sum_{a \in A} c_a x_a \tag{3.1}$$

$$\text{s.t. } x(\delta^+(v)) = x(\delta^-(v)) \quad (v \in V), \tag{3.2}$$

$$x(\delta(U)) \geq 2 \quad (\emptyset \neq U \subset V), \tag{3.3}$$

$$x_a \in \mathbb{Z}_+ \quad (a \in A). \tag{3.4}$$

Here, equation (3.2) ensures that an arbitrary feasible solution induces a Eulerian multi-subgraph and (3.3) is the classic subtour elimination constraint. We denote optimum values of problem (3.1)–(3.4) and its LP-relaxation as ATSP* and ATSP-LP*, respectively.

In their seminal paper [28], O. Svensson, J. Tarnavski, and L. Végh provided the first polynomial time approximation for the ATSP within a fixed ratio. A few years later, this breakthrough result was substantially improved by V. Traub and J. Vygen in [29]. We remind this result, since it is one of the main building blocks of our own contribution.

Theorem 1. *For an arbitrary positive ε , there exists a polynomial-time algorithm that finds a feasible tour T for the given ATSP instance, such that*

$$\text{ATSP}^* \leq c(T) \leq (22 + \varepsilon) \text{ATSP-LP}^*.$$

We employ this result to prove the similar approximation result for the special case of the PCATSP, where all feasible walks are restricted to visit a given pair of nodes $\{u, v\} \subset V$, we call this problem PCATSP $_{u,v}$. Following the known results (see, e.g. [6, 11]), we propose the MILP-model for this problem:

$$\min \sum_{a \in A} c_a x_a + \sum_{w \in V} \pi_w (1 - y_w) \tag{3.5}$$

$$\text{s.t. } x(\delta^+(w)) = x(\delta^-(w)) \quad (w \in V), \tag{3.6}$$

$$x(\delta(S)) \geq 2 \quad (S \subset V : |S \cap \{u, v\}| = 1), \tag{3.7}$$

$$x(\delta(S)) \geq 2y_w \quad (\emptyset \neq S \subseteq V \setminus \{u, v\}, w \in S), \tag{3.8}$$

$$x_a \in \mathbb{Z}_+, \quad y_w \in \{0, 1\}, \tag{3.9}$$

$$y_u = y_v = 1, \tag{3.10}$$

where, for the tour W , the Boolean variable y_w indicates of whether W visits the node $w \in V$, total transportation costs and node-skipping penalties accumulated by W are represented by the objective function (3.5), equation (3.6) guarantees that the multigraph (V, W) is Eulerian and, together with (3.7)–(3.8), ensures its connectivity.

As for the Held-Karp model, we assign an LP-relaxation PCATSP-LP $_{u,v}$ to the problem PCATSP $_{u,v}$, where constraint (3.9) is relaxed by $x_a \geq 0$ and $y_w \in [0, 1]$, and denote by PCATSP* $_{u,v}$, PCATSP-LP* $_{u,v}$, and $\mathcal{TC}(\text{PCATSP-LP}_{u,v})$ the optimum values of the problem PCATSP $_{u,v}$ and problem PCATSP-LP $_{u,v}$ and the time complexity of the PCATSP-LP $_{u,v}$, respectively.

4. Approximation algorithm

We start with an approximation algorithm (Algorithm $\mathcal{A}_{u,v}$) for the PCATSP $_{u,v}$ used as a subroutine in our main Algorithm \mathcal{A} for the PCATSP.

Algorithm $\mathcal{A}_{u,v}$ employs two outer parameters. The former one is an arbitrary approximation Algorithm \mathcal{A}_0 for the asymmetric ATSP. For any ATSP instance I and some $\alpha \geq 0$, this algorithm finds an approximate solution $T = T(I)$, such that:

$$\text{ATSP}^* \leq c(T) \leq \alpha \cdot \text{ATSP-LP}^*. \quad (4.1)$$

The latter parameter gives a threshold value τ separating full-size auxiliary ATSP instances approximated using algorithm \mathcal{A}_0 from the smaller ones, which are solved to optimality.

Algorithm $\mathcal{A}_{u,v}$

Input: an instance of the PCATSP $_{u,v}$

Parameters: an approximation algorithm \mathcal{A}_0 for the ATSP with triangle inequality, a threshold $\tau \geq 3$

Output: an approximate solution $W_{u,v}$ of this instance

- 1: find an optimum solution (\bar{x}, \bar{y}) for the PCATSP-LP $_{u,v}$
- 2: define the subset $V_{u,v} \subset V$ as follows:

$$V_{u,v} = \left\{ w \in V : \bar{y}_w \geq \frac{\alpha}{\alpha + 1} \right\},$$

by construction, $\{u, v\} \subset V_{u,v}$

- 3: consider an ATSP instance $I_{u,v}$ on the subgraph $G\langle V_{u,v} \rangle$ induced by the subset $V_{u,v}$
 - 4: **if** $|V_{u,v}| > \tau$ **then**
 - 5: set $W_{u,v}$ to an approximate solution of $I_{u,v}$ found by Algorithm \mathcal{A}_0
 - 6: **else**
 - 7: set $W_{u,v}$ to an optimum solution of this instance
 - 8: **end if**
 - 9: output $W_{u,v}$
-

Algorithm \mathcal{A} is based on the following simple decomposition idea:

- (i) by construction, any feasible solution of the PCATSP is either a closed walk $W_{u,v}$ visiting at least two nodes u and v of the input graph G or an empty walk that does not visit any node at all;
- (ii) in the former case, the walk $W_{u,v}$ is a feasible solution of the appropriate restricted problem PCATSP $_{u,v}$ and has the cost

$$\text{cost}(W_{u,v}) = \sum_{a \in W_{u,v}} c_a x_a + \sum_{w \notin V'} \pi_w,$$

where x_a denotes the inclusion multiplicity for the arc a in the walk $W_{u,v}$ and V' is the subset of nodes visited by this walk;

- (iii) in the latter case, the cost of the empty walk is $\sum_{w \in V} \pi_w$.

Finally, the initial PCATSP is decomposed as follows:

$$\text{PCATSP}^* = \min \left\{ \sum_{w \in V} \pi_w, \min \{ \text{PCATSP}_{u,v}^* : \{u, v\} \subset V \} \right\}. \quad (4.2)$$

Algorithm \mathcal{A}

Input: an instance of the PCATSP

Output: an $(\alpha + 1)$ -approximate solution of this instance

- 1: initialize the set of candidate solutions $\mathcal{C} = \emptyset$
 - 2: **for all** $\{u, v\} \subset V$ **do**
 - 3: construct the auxiliary instance $\text{PCATSP}_{u,v}$
 - 4: employ Algorithm $\mathcal{A}_{u,v}$ to find its approximate solution $W_{u,v}$
 - 5: append the walk $W_{u,v}$ to \mathcal{C}
 - 6: **end for**
 - 7: let $\bar{W} = \arg \min \{ \text{cost}(W_{u,v}) : W_{u,v} \in \mathcal{C} \}$
 - 8: **if** $\text{cost}(\bar{W}) \leq \sum_{w \in V} \pi_w$ **then**
 - 9: output \bar{W}
 - 10: **else**
 - 11: output the empty walk
 - 12: **end if**
-

5. Theoretical guarantees

First of all, we show that Algorithm $\mathcal{A}_{u,v}$, as an algorithm for $\text{PCATSP}_{u,v}$, inherits all the approximation features of algorithm \mathcal{A}_0 for the ATSP with the triangle inequality. In particular, if we take the Svensson-Traub algorithm, then Algorithm $\mathcal{A}_{u,v}$, in polynomial time, will find an approximate solution of the subproblem $\text{PCATSP}_{u,v}$, whose cost does not exceed $(23 + \varepsilon) \text{PCATSP-LP}_{u,v}^*$.

We start with the following technical lemma.

Lemma 1. *For each $V_{u,v} \subset V$, such that $|V_{u,v}| > 3$, the optimum value of the problem*

$$\min \sum c_a x_a \quad (5.1)$$

$$\text{s.t. } x(\delta^+(w)) = x(\delta^-(w)) \quad (w \in V), \quad (5.2)$$

$$x(\delta(U)) \geq 2 \begin{pmatrix} U \subset V : V_{u,v} \cap U \neq \emptyset, \\ V_{u,v} \cap V \setminus U \neq \emptyset \end{pmatrix}, \quad (5.3)$$

$$x_a \geq 0 \quad (a \in A), \quad (5.4)$$

$$x(\delta(w)) \begin{cases} \geq 2, & \text{if } w \in V_{u,v}, \\ = 0, & \text{otherwise} \end{cases} \quad (5.5)$$

is equal to the optimum value of problem (5.1)–(5.4).

Lemma 1 can be derived from a much more general result on connectivity of Eulerian graphs obtained by L. Lovász [22] and B. Jackson [18]. Nevertheless, we prefer to present its direct proof, since, in our case, it appears to be much simpler.

P r o o f. Indeed, denote by X_1^* and X_2^* optimal sets of the problem (5.1)–(5.4) and (5.1)–(5.5), respectively. We show that an arbitrary rational solution

$$x^* = \arg \min \left\{ \sum_{a \in A} x_a : x \in X_1^* \right\} \quad (5.6)$$

belongs to X_2^* . To prove it, it is sufficient to show that $x^*(\delta(w)) = 0$ for an arbitrary $w \notin V_{u,v}$, since, for any $w \in V_{u,v}$, inequality $x^*(\delta(w)) \geq 2$ follows straightforwardly from equation (5.3). By construction, there exists a number $D \geq 1$, such that the vector $\xi^* = D \cdot x^*$ is an integer and fulfills the following constraints:

$$\xi(\delta^+(w)) = \xi(\delta^-(w)) \quad (w \in V), \quad (5.7)$$

$$\xi(\delta(S)) \geq 2D \quad (S \in \mathcal{S}_{u,v}), \quad (5.8)$$

$$\xi \geq 0, \quad (5.9)$$

where

$$\mathcal{S}_{u,v} = \{S \subset V : V_{u,v} \cap S \neq \emptyset, V_{u,v} \setminus S \neq \emptyset\}$$

and $\xi^*(\delta(S))$ is even for an arbitrary $S \subset V$.

Assume that there exists $w_0 \notin V_{u,v}$, for which $\xi^*(\delta(w_0)) > 0$. Obviously, inequality (5.8) holds tight for at least one subset $\bar{S} \in \mathcal{S}_{u,v}$. Indeed, otherwise, for some nodes w' and w'' neighboring to w_0 , for which $\xi^*(a) > 0$, $a \in \{(w', w_0), (w_0, w'')\}$, there exists the vector $\tilde{\xi}$, built as follows:

$$\tilde{\xi}_a = \begin{cases} \xi_a^* - 1, & \text{for } a = (w', w_0) \text{ or } a = (w_0, w'') \\ \xi_a^* + 1, & \text{for } a = (w', w'') \\ \xi_a^*, & \text{for any other arc.} \end{cases} \quad (5.10)$$

By construction, $\tilde{\xi}$ satisfies equations (5.7)–(5.9). Furthermore,

$$\sum_{a \in A} \tilde{\xi}_a = \sum_{a \in A} \xi_a^* - 1, \quad \text{and} \quad \sum_{a \in A} c_a \tilde{\xi}_a \leq \sum_{a \in A} c_a \xi_a^*,$$

by triangle inequality. Therefore, the vector $\tilde{x} = 1/D \cdot \tilde{\xi}$ is feasible in the problem (5.1)–(5.4), it belongs to X_1^* , and

$$\sum_{a \in A} \tilde{x}_a = \sum_{a \in A} x_a^* - \frac{1}{D}$$

that contradicts to (5.6).

Therefore, we proved that there exists a subset $\bar{S} \in \mathcal{S}_{u,v}$, $w_0 \notin \bar{S}$ and the neighbors $w', w'' \in \bar{S}$, such that $\xi^*(\delta(\bar{S})) = 2D$, and $\tilde{\xi}(\delta(\bar{S})) = 2D - 2$. Notice that, even in this case, any time, when $\{w', w''\} \cap V_{u,v} = \emptyset$, transform (5.10) still provides feasible solution \tilde{x} that contradicts to minimality of x^* . Therefore, in the sequel, we assume without of loss of generality that $w' \in V_{u,v}$.

Denote by S' the maximal subset of $V \setminus \{w_0\}$, such that $S' \in \mathcal{S}_{u,v}$, $w' \in S'$, and $\xi^*(\delta(S')) = 2D$. Since

$$w_0 \notin V_{u,v}, \quad V_{u,v} \setminus (S' \cup \{w_0\}) \neq \emptyset \quad \text{and} \quad \xi^*(\delta(S' \cup \{w_0\})) \geq 2D.$$

Therefore, S' cannot contain all the neighbors of w_0 , since, otherwise (see Fig. 1)

$$2D \leq \xi^*(\delta(S' \cup \{w_0\})) < \xi^*(\delta(S')) = 2D.$$

Further, consider the subsets S' and \bar{S} . Since

$$S' \cap \bar{S} \neq \emptyset, \quad V \setminus (S' \cup \bar{S}) \neq \emptyset, \quad \bar{S} \setminus S' \neq \emptyset, \quad \text{and} \quad S' \setminus \bar{S} \neq \emptyset,$$

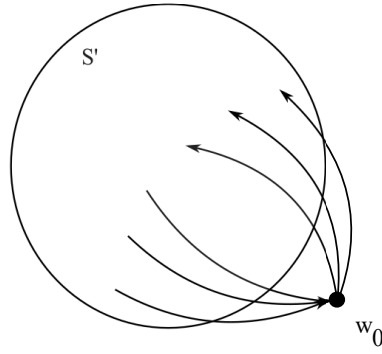

Figure 1. Example of subset S' , node w_0 , and its neighbors.

for an arbitrary vector ξ satisfying (5.7)–(5.9), the following inequalities

$$\xi(\delta(S' \setminus \bar{S})) + \xi(\delta(\bar{S} \setminus S')) \leq \xi(\delta(S')) + \xi(\delta(\bar{S})), \quad (5.11)$$

$$\xi(\delta(S' \cup \bar{S})) + \xi(\delta(S' \cap \bar{S})) \leq \xi(\delta(S')) + \xi(\delta(\bar{S})) \quad (5.12)$$

are valid. Indeed, as it follows from Fig. 2,

$$\begin{aligned} \xi(\delta(S' \setminus \bar{S})) &= a + b + d, & \xi(\delta(\bar{S} \setminus S')) &= c + d + e, \\ \xi(\delta(S' \cup \bar{S})) &= a + e + f, & \xi(\delta(S' \cap \bar{S})) &= b + c + f, \\ \xi(\delta(S')) &= a + c + d + f, & \xi(\delta(\bar{S})) &= b + d + e + f. \end{aligned}$$

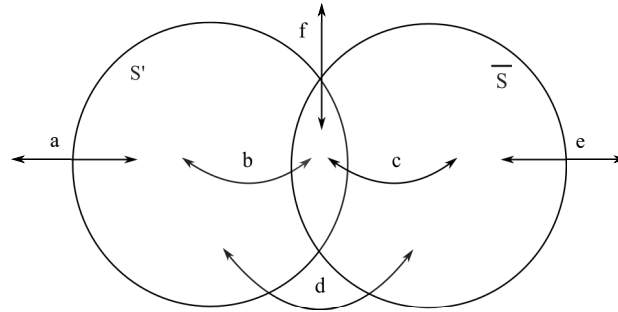

Figure 2. Cut sizes: $a = |\delta(S' \setminus \bar{S}, V \setminus (S' \cup \bar{S}))|$; $b = |\delta(S' \setminus \bar{S}, S' \cap \bar{S})|$; $c = |\delta(\bar{S} \setminus S', S' \cap \bar{S})|$; $d = |\delta(S' \setminus \bar{S}, \bar{S} \setminus S')|$; $e = |\delta(\bar{S} \setminus S', V \setminus (S' \cup \bar{S}))|$; $f = |\delta(S' \cap \bar{S}, V \setminus (S' \cup \bar{S}))|$.

Therefore, inequalities (5.11) and (5.12) hold for any non-negative function c of transportation costs. Furthermore, for ξ^* ,

$$\xi^*(\delta(S' \setminus \bar{S})) + \xi^*(\delta(\bar{S} \setminus S')) < \xi^*(\delta(S')) + \xi^*(\delta(\bar{S})), \quad (5.13)$$

by construction. Next, by assumption, $w' \in V_{u,v} \cap S' \cap \bar{S}$, $w'' \in \bar{S} \setminus S'$, and $w_0 \notin S'$, which imply $\xi^*(\delta(S' \cap \bar{S})) \geq 2D$. Thus, we obtain

$$\xi^*(\delta(S' \cup \bar{S})) \leq 2D,$$

due to (5.12) and the equality

$$\xi^*(\delta(S')) = \xi^*(\delta(\bar{S})) = 2D. \quad (5.14)$$

Consequently, $V_{u,v} \subset S' \cup \bar{S}$, since otherwise, taking into account the inequality $V_{u,v} \cap (\bar{S} \cap S') \neq \emptyset$, we come to contradiction with the maximality of the subset S' .

Coming back to the subsets $\bar{S} \setminus S'$ and $S' \setminus \bar{S}$, we can easily show that each belong to $\mathcal{S}_{u,v}$, which implies

$$\xi^*(\delta(S' \setminus \bar{S})) \geq 2D \quad \text{and} \quad \xi^*(\delta(\bar{S} \setminus S')) \geq 2D.$$

These equations together with (5.14) contradict (5.13). Lemma 1 is proved. \square

Theorem 2. *If the Algorithm \mathcal{A}_0 approximates the ATSP in time $\mathcal{TC}(\mathcal{A}_0)$ within the accuracy bound (4.1), then the Algorithm $\mathcal{A}_{u,v}$, in time $\mathcal{TC}(\mathcal{A}_0) + \mathcal{TC}(\text{PCATSP-LP}_{u,v})$, finds an approximate solution $W_{u,v}$ of the PCATSP $_{u,v}$, for which*

$$\text{PCATSP}_{u,v}^* \leq \text{cost}(W_{u,v}) \leq (\alpha + 1) \text{PCATSP-LP}_{u,v}^*. \quad (5.15)$$

P r o o f. Since the description of the Algorithm $\mathcal{A}_{u,v}$ leads to a straightforward upper bound of its time complexity, we proceed with the bound of its approximation ratio (5.15). Indeed, make a simple transformation of the fractional solution (\bar{x}, \bar{y}) obtained at Step 1 of the Algorithm $\mathcal{A}_{u,v}$ as follows:

$$\hat{x} = \frac{\alpha + 1}{\alpha} \cdot \bar{x}, \quad \hat{y}_w = \begin{cases} 1, & \text{if } \bar{y}_w \geq \alpha/(\alpha + 1), \\ 0, & \text{otherwise.} \end{cases} \quad (w \in V). \quad (5.16)$$

Further, the set $V_{u,v}$ defined at Step 2 of the Algorithm $\mathcal{A}_{u,v}$ obeys the equation

$$V_{u,v} = \{w \in V : \hat{y}_w = 1\},$$

by construction. We consider the non-trivial case, where $|V_{u,v}| > \tau$. Then, $W_{u,v}$ coincides with an approximate solution of the auxiliary ATSP instance defined on the subgraph $G\langle V_{u,v} \rangle$ provided by Algorithm \mathcal{A}_0 . Denote by x' the appropriate feasible solution of its MIP-model

$$\min \sum c_a x_a \quad (5.17)$$

$$\text{s.t. } x(\delta^+(w)) = x(\delta^-(w)) \quad (w \in V_{u,v}), \quad (5.18)$$

$$x(\delta(U)) \geq 2 \quad (\emptyset \neq U \subset V_{u,v}), \quad (5.19)$$

$$x_a \in \mathbb{Z}_+. \quad (5.20)$$

By condition,

$$\text{ATSP}^* \leq c(x') \leq \alpha \cdot \text{ATSP-LP}^*.$$

In turn, the LP-relaxation of problem (5.17)–(5.20), the problem ATSP LP, appears to be equivalent to the problem (5.1)–(5.5), whose optimum value is equal to the optimum value of the problem (5.1)–(5.4), by Lemma 1.

Further, we prove that the vector \hat{x} is a feasible solution of problem (5.1)–(5.4). Indeed, equation (5.2) follows from (3.6), since $\hat{x} = (\alpha + 1)/\alpha \cdot \bar{x}$. In order to prove that \hat{x} satisfies equation (5.3), notice that, if $|\{u, v\} \cap S| = 1$, it easily follows from (3.7).

Next, suppose that $S \cap \{u, v\} = \emptyset$ (the case $\{u, v\} \subset S$ can be tackled by analogy). For an arbitrary $w \in V_{u,v} \cap S$, we have $\hat{y}_w = 1$, i.e. $\bar{y}_w \geq \alpha/(\alpha + 1)$. Therefore,

$$\hat{x}(\delta(S)) = \sum_{e \in \delta(S)} \hat{x}_e = \frac{\alpha + 1}{\alpha} \sum_{e \in \delta(S)} \bar{x}_e \geq \frac{\alpha + 1}{\alpha} \cdot 2\bar{y}_w \geq 2,$$

since, $\bar{x}(\delta(w)) \geq 2\bar{y}_w$.

Thus, we showed that \hat{x} is a feasible solution of the problem (5.1)–(5.4), whose optimum value equals to ATSP-LP*, i.e.

$$c(x') \leq \alpha \cdot \text{ATSP-LP}^* \leq \alpha \cdot c(\hat{x}).$$

Therefore, for the feasible solution (x', \hat{y}) (induced by the walk $W_{u,v}$) of the problem (3.5)–(3.10), we have

$$\begin{aligned} \text{PCATSP}_{u,v}^* &\leq \text{cost}(W_{u,v}) = c(x') + \sum_{w \in V} \pi_w(1 - \hat{y}_w) \leq \alpha \cdot \text{ATSP-LP}^* \\ &+ \sum_{w \in V} \pi_w(1 - \hat{y}_w) \leq \alpha \cdot c(\hat{x}) + \sum_{w \in V} \pi_w(1 - \hat{y}_w) = (\alpha + 1) \cdot c(\bar{x}) + \sum_{w \in V} \pi_w(1 - \hat{y}_w). \end{aligned}$$

Taking into account the inequality

$$1 - \hat{y}_w \leq (\alpha + 1)(1 - \bar{y}_w)$$

following straightforwardly from (5.16), we obtain

$$\frac{\text{cost}(W_{u,v})}{\text{PCATSP-LP}_{u,v}^*} \leq \frac{(\alpha + 1) \cdot c(\bar{x}) + (\alpha + 1) \sum_{w \in V} \pi_w(1 - \bar{y}_w)}{c(\bar{x}) + \sum_{w \in V} \pi_w(1 - \bar{y}_w)} = \alpha + 1.$$

Theorem 2 is proved. \square

Finally, we obtain our main result, which easily follows from Theorem 2.

Theorem 3. *From Theorem 2 it follows that Algorithm \mathcal{A} finds $(\alpha + 1)$ -approximate feasible solution of the PCATSP in time*

$$O(n^2 \cdot (\mathcal{TC}(\mathcal{A}_0) + \mathcal{TC}(\text{PCATSP-LP}_{u,v}))). \quad (5.21)$$

P r o o f. First, we obtain an upper accuracy bound for Algorithm \mathcal{A} . Without loss of generality, we skip the trivial case, where, for the given PCATSP instance, an arbitrary non-empty walk is dominated by the empty walk and

$$\text{PCATSP}^* = \sum_{w \in V} \pi_w.$$

Then, in (4.2), the minimum is achieved at some pair $\{\tilde{u}, \tilde{v}\} \subset V$. Therefore, for the output walk \bar{W} , by Theorem 2 we have

$$\begin{aligned} \text{PCATSP}^* &\leq \text{cost}(\bar{W}) \leq \text{cost}(W_{\tilde{u}, \tilde{v}}) \leq (\alpha + 1) \cdot \text{PCATSP-LP}_{\tilde{u}, \tilde{v}}^* \\ &\leq (\alpha + 1) \cdot \text{PCATSP}_{\tilde{u}, \tilde{v}}^* = (\alpha + 1) \cdot \text{PCATSP}^*. \end{aligned}$$

In turn, the complexity bound (5.21) easily follows from the construction of Algorithm \mathcal{A} and Theorem 2. Indeed, the running time of Algorithm \mathcal{A} is determined by the for-loop statement located between its Step 2 and Step 6. At each iteration of this loop, we employ Algorithm $\mathcal{A}_{u,v}$ to one of $O(n^2)$ auxiliary instances of the PCATSP $_{u,v}$. Theorem 3 is proved. \square

Remark 1. Exploiting the recent $(22 + \varepsilon)$ -approximation algorithm for the ATSP, for an arbitrary $\varepsilon > 0$ we obtain the polynomial-time algorithm for the PCATSP within approximation ratio $(23 + \varepsilon)$.

Remark 2. Since auxiliary instances PCATSP $_{u,v}$ are mutually independent, all of them can be approximated in parallel. In this case, the running-time bound of Algorithm \mathcal{A} coincides asymptotically with the running-time bound of Algorithm $\mathcal{A}_{u,v}$.

6. Conclusion

In this paper, we proposed the first fixed-ratio $(23 + \varepsilon)$ -approximation algorithm for the PCATSP. By its appearance, our algorithm owes to the recent breakthrough results of O. Svensson and V. Traub [28, 29] for the asymmetric TSP, who make possible polynomial time approximation for asymmetric versions of other routing problems within fixed ratios. To future work, we postpone reports on some algorithms of such kind including the algorithm for the general version of the PCATSP.

REFERENCES

1. Archer A., Bateni M., Hajiaghayi M., Karloff H. Improved approximation algorithms for prize-collecting Steiner tree and TSP. *SIAM J. Comput.*, 2011. Vol. 40, No. 2. P. 309–332. DOI: [10.1137/090771429](https://doi.org/10.1137/090771429)
2. Balas E. The prize collecting traveling salesman problem. *Networks*, 1989. Vol. 19, No. 6. P. 621–636. DOI: [10.1002/net.3230190602](https://doi.org/10.1002/net.3230190602)
3. Bartal Y., Gottlieb L. A., Krauthgamer R. The traveling salesman problem: low-dimensionality implies a polynomial time approximation scheme. *SIAM J. Comput.*, 2016. Vol. 45, No. 4. P. 1563–1581. DOI: [10.1137/130913328](https://doi.org/10.1137/130913328)
4. Bateni M., Chekuri C., Ene A., Hajiaghayi M., Korula N., Marx D. Prize-collecting Steiner problems on planar graphs. In: *Proc. 2011 Annual ACM-SIAM Symposium on Discrete Algorithms (SODA)*, 2011. P. 1028–1049. DOI: [10.1137/1.9781611973082.79](https://doi.org/10.1137/1.9781611973082.79)
5. Bérubé J. F., Gendreau M., Potvin J.-Y. A branch-and-cut algorithm for the undirected prize collecting traveling salesman problem. *Networks*, 2009. Vol. 54, No. 1. P. 56–67. DOI: [10.1002/net.20307](https://doi.org/10.1002/net.20307)
6. Bienstock D., Goemans M. X., Simchi-Levi D., Williamson D. A note on the prize collecting traveling salesman problem. *Math. Program.*, 1993. Vol. 59. P. 413–420. DOI: [10.1007/BF01581256](https://doi.org/10.1007/BF01581256)
7. Chan T.-H. H., Jiang H., Jiang S. H. C. A unified PTAS for prize collecting TSP and Steiner tree problem in doubling metrics. In: *LIPICs. Leibniz Int. Proc. Inform., vol. 112: 26th Annual European Symposium on Algorithms (ESA 2018)*, Y. Azar, H. Bast, G. Herman (eds.). Dagstuhl, Germany: Schloss Dagstuhl–Leibniz-Zentrum fuer Informatik, 2018. Art. no. 15. P. 1–13. DOI: [10.4230/LIPICs.ESA.2018.15](https://doi.org/10.4230/LIPICs.ESA.2018.15)
8. Chan T.-H. H., Jiang S. H. C. Reducing curse of dimensionality: improved PTAS for TSP (with neighborhoods) in doubling metrics. *ACM Trans. Algorithms*, 2018. Vol. 14, No. 1. Art. no. 9. P. 1–18. DOI: [10.1145/3158232](https://doi.org/10.1145/3158232)
9. Christofides N. Worst-case analysis of a new heuristic for the traveling salesman problem. In: *Abstr. of Symposium on New Directions and Recent Results in Algorithms and Complexity*, J. F. Traub (ed.). NY: Academic Press, 1976. P. 441.
10. Chung S. H., Sah B., Lee J. Optimization for drone and drone-truck combined operations: A review of the state of the art and future directions. *Comput. Oper. Res.*, 2020. Vol. 123. P. 105004. DOI: [10.1016/j.cor.2020.105004](https://doi.org/10.1016/j.cor.2020.105004)
11. Climaco G., Simonetti L., Rosetti I. A Branch-and-Cut and MIP-based heuristics for the Prize-Collecting Travelling Salesman Problem. *RAIRO-Oper. Res.*, 2021. Vol. 55. P. S719–S726. DOI: [10.1051/ro/2020002](https://doi.org/10.1051/ro/2020002)
12. Dell’Amico M., Maffioli F., Värbrand P. On prize-collecting tours and the asymmetric travelling salesman problem. *Int. Trans. Oper. Res.*, 1995. Vol. 2, No. 3. P. 297–308. DOI: [10.1016/0969-6016\(95\)00010-5](https://doi.org/10.1016/0969-6016(95)00010-5)
13. Dogan O., Alkaya A. F. A novel method for prize collecting traveling salesman problem with time windows. In: *Lect. Notes Networks Systems, vol 307: Intelligent and Fuzzy Techniques for Emerging Conditions and Digital Transformation*, C. Kahraman et al. (eds.). Cham: Springer, 2022. P. 469–476. DOI: [10.1007/978-3-030-85626-7_55](https://doi.org/10.1007/978-3-030-85626-7_55)
14. Feillet D., Dejax P., Gendreau M. Traveling salesman problems with profits. *Transport. Sci.*, 2005. Vol. 39, No. 2. P. 188–205. DOI: [10.1287/trsc.1030.0079](https://doi.org/10.1287/trsc.1030.0079)
15. Fischetti M., Toth P. An additive approach for the optimal solution of the prize collecting traveling salesman problem. In: *Vehicle Routing: Methods and Studies*, B. L. Golden, A. A. Assad (eds.). North-Holland, 1988. P. 319–343.
16. Goemans M. X., Williamson D. P. A general approximation technique for constrained forest problems. *SIAM J. Comput.*, 1995. Vol. 24, No. 2. P. 296–317. DOI: [10.1137/S0097539793242618](https://doi.org/10.1137/S0097539793242618)

17. Gutin G., Punnen A.P. *The Traveling Salesman Problem and Its Variations*. Boston, MA: Springer US, 2007. 38 p.
18. Jackson B. Some remarks on Arc-connectivity, vertex splitting, and orientation in graphs and digraphs. *J. Graph Theory*, 1988. Vol. 12, No. 3. P. 429–436. DOI: [10.1002/jgt.3190120314](https://doi.org/10.1002/jgt.3190120314)
19. Khachay M., Ogorodnikov Y., Khachay D. Efficient approximation of the metric CVRP in spaces of fixed doubling dimension. *J. Global Optim.*, 2021. Vol. 80. P. 679–710. DOI: [10.1007/s10898-020-00990-0](https://doi.org/10.1007/s10898-020-00990-0)
20. Khachai D., Sadykov R., Battaiia O., Khachay M. Precedence constrained generalized traveling salesman problem: Polyhedral study, formulations, and branch-and-cut algorithm. *European J. Oper. Res.*, 2023. Vol. 309, No. 2. P. 488–505. DOI: [10.1016/j.ejor.2023.01.039](https://doi.org/10.1016/j.ejor.2023.01.039)
21. Lahyani R., Khemakhem M., Semet F. A unified matheuristic for solving multi-constrained traveling salesman problems with profits. *EURO J. Comput. Optim.*, 2017. Vol. 5, No. 3. P. 393–422. DOI: [10.1007/s13675-016-0071-1](https://doi.org/10.1007/s13675-016-0071-1)
22. Lovász L. On some connectivity properties of Eulerian graphs. *Acta Math. Acad. Scientiarum Hungarica*, 1976. Vol. 28, No. 1. P. 129–138. DOI: [10.1007/BF01902503](https://doi.org/10.1007/BF01902503)
23. de Medeiros Y. A., Goldberg M. C., Goldberg E. F. G. Prize collecting traveling salesman problem with ridesharing. *Revista de Informática Teórica e Aplicada*, 2020. Vol. 27, No. 2. P. 13–29. DOI: [10.22456/2175-2745.94082](https://doi.org/10.22456/2175-2745.94082)
24. Nguyen V. H., Nguyen T. T. T. Approximating the asymmetric profitable tour. *Electron. Notes Discrete Math.*, 2010. Vol. 36. P. 907–914. DOI: [10.1016/j.endm.2010.05.115](https://doi.org/10.1016/j.endm.2010.05.115)
25. Papadimitriou C. The Euclidean travelling salesman problem is NP-complete. *Theoret. Comput. Sci.*, 1977. Vol. 4, No. 3. P. 237–244. DOI: [10.1016/0304-3975\(77\)90012-3](https://doi.org/10.1016/0304-3975(77)90012-3)
26. Pedro O., Saldanha R., Camargo R. A tabu search approach for the prize collecting traveling salesman problem. *Electron. Notes Discrete Math.*, 2013. Vol. 41. P. 261–268. DOI: [10.1016/j.endm.2013.05.101](https://doi.org/10.1016/j.endm.2013.05.101)
27. Sahni S. *P*-complete approximation problems. *J. ACM*, 1976. Vol. 23, No. 3. P. 555–565.
28. Svensson O., Tarnawski J., Végh L. A. A constant-factor approximation algorithm for the asymmetric traveling salesman problem. In: *Proc. 50th Annual ACM SIGACT Symposium on Theory of Computing (STOC 2018)*. New York, USA: Association for Computing Machinery, 2018. P. 204–213. DOI: [10.1145/3188745.3188824](https://doi.org/10.1145/3188745.3188824)
29. Traub V., Vygen J. An improved approximation algorithm for ATSP. In: *Proc. 52nd Annual ACM SIGACT Symposium on Theory of Computing (STOC 2018)*. New York, USA: Association for Computing Machinery, 2020. P. 1–13. DOI: [10.1145/3357713.3384233](https://doi.org/10.1145/3357713.3384233)
30. Vansteenwegen P., Gunawan A. *Orienteering Problems: Models and Algorithms for Vehicle Routing Problems with Profits*. Cham: Springer, 2019. 112 p. DOI: [10.1007/978-3-030-29746-6](https://doi.org/10.1007/978-3-030-29746-6)

HYERS–ULAM–RASSIAS STABILITY OF NONLINEAR DIFFERENTIAL EQUATIONS WITH A GENERALIZED ACTIONS ON THE RIGHT-HAND SIDE¹

Alexander N. Sesekin[†], Anna D. Kandrina^{††}

Ural Federal University,
19 Mira str., Ekaterinburg, 620002, Russian Federation

[†]a.n.sesekin@urfu.ru ^{††}anna_kandrina@mail.ru

Abstract: The paper considers the Hyers–Ulam–Rassias stability for systems of nonlinear differential equations with a generalized action on the right-hand side, for example, containing impulses — delta functions. The fact that the derivatives in the equation are considered distributions required a correction of the well-known Hyers–Ulam–Rassias definition of stability for such equations. Sufficient conditions are obtained that ensure the property under study.

Keywords: Hyers–Ulam–Rassias stability, Differential equations, Generalized actions, Discontinuous trajectories.

1. Introduction

The definition of the Hyers–Ulam stability appeared after Hyers gave a solution to the Ulam problem on conditions for the proximity of an additive mapping and an approximate additive mapping [1]. Then these results were interpreted for differential equations, which is reflected in many publications (see, for example, [4, 6] and the references therein). Further development of the Hyers–Ulam stability concept was developed in [5]. As a result, the concept of the Hyers–Ulam–Rassias stability arose.

The paper considers sufficient conditions for the Hyers–Ulam–Rassias stability of generalized solutions to nonlinear differential systems with a generalized action on the right-hand side. These issues for ordinary differential equations with absolutely continuous trajectories were considered, for example, in [6]. A distinctive feature of this work is that the right-hand side of the differential equation contains generalized actions — generalized derivatives of functions of bounded variation. Solutions are understood as pointwise limits of sequences of absolutely continuous solutions, which are obtained as a result of approximations of generalized actions on the right-hand side of the equation by summable functions [2, 8, 11]. The results obtained by the authors differ from [9, 10] in that [9, 10] use the solution formalization proposed in [7], while we use the solution formalization described in [8, 11].

For differential equations, the Hyers–Ulam–Rassias stability is defined as follows (see, for example, [6]).

Definition 1. *The equation*

$$\dot{x}(t) = f(t, x) \tag{1.1}$$

is Hyers–Ulam–Rassias stable with respect to a function φ (φ is a positive, continuous, nondecreasing function) if there exists a number $c_{f\varphi} > 0$ such that, for every ε and every solution $y \in C^1[a, b]$

¹This work was supported by the Russian Science Foundation (project no. 22-21-00714).

to the inequality

$$|y' - f(t, y)| \leq \varepsilon\varphi(t), \quad t \in [a, b],$$

there exists a solution $x(t)$ to equation (1.1) satisfying the inequality

$$|y(t) - x(t)| \leq c_{f\varphi}\varepsilon\varphi(t), \quad t \in [a, b].$$

Obviously, such a definition does not apply to equations with a generalized action because the right-hand side of the equation is unbounded. For linear differential equations of the first and second orders, the authors of [3] proposed a formalization of the Hyers–Ulam stability for a differential equation and obtained conditions for the presence of such stability for these equations.

2. Formulation of the problem

We will consider the following differential equation:

$$\dot{x} = f(t, x) + B(t, x)\dot{v}(t). \quad (2.1)$$

Here, $x(t)$ and $v(t)$ are n - and m -dimensional vector functions, respectively, $f(t, x)$ is an n -dimensional vector function, and $B(t, x)$ is an $n \times m$ -matrix function. If the function $v(t)$ is absolutely continuous, then, under certain assumptions on $f(t, x)$ and $B(t, x)$, there exists a unique solution to equation (2.1) on the segment $[t_0, \vartheta]$ satisfying the initial condition $x(t_0) = x^0$.

If $v(t)$ is a function of bounded variation, then the derivative in equation (2.1) should be understood in the generalized sense [11]. As a result, an incorrect operation of multiplication of a discontinuous function by a generalized function occurs on the right-hand side of the equation. One of possible ways to solve this problem is based on the definition of the solution on the closure of the set of smooth solutions in the space of functions of bounded variation [2, 11]. Since the variation of a vector function can be defined in different ways, we note that, in this paper, the variation of an m -dimensional vector function $v(t)$ is understood as

$$\text{var}_{[t_0, t]} v(\cdot) = \sup_T \sum_{i=0}^{k-1} |v(t_{i+1}) - v(t_i)|,$$

where T is an arbitrary partition of the segment $[t_0, t]$.

According to [11], by an approximable solution of (2.1) corresponding to a function of bounded variation $v(t)$, we mean a function of bounded variation $x(t)$ which is the pointwise limit of a sequence $x_k(t)$ generated by a sequence of absolutely continuous functions $v_k(t)$ converging pointwise to $v(t)$ if $x(t)$ does not depend on the choice of the sequence $v_k(t)$.

Theorem 1 [11, p. 214]. *Assume that, in a domain $t \in [t_0, \vartheta]$, $x \in \mathbb{R}^n$, $v \in \mathbb{R}^m$, $v(\cdot)$ is a function of bounded variation, and the components of the vector $f(t, x)$ and the elements of the matrix $B(t, x)$ are continuous in the set of variables, differentiable with respect to all variables x_i , $i \in \overline{1, n}$, and satisfy the inequalities*

$$\|f(t, x)\| \leq \kappa(1 + \|x\|), \quad \|B(t, x)\| \leq \kappa(1 + \|x\|), \quad (2.2)$$

$$\|f(t, x) - f(t, y)\| \leq L_f|x - y|, \quad \|B(t, x) - B(t, y)\| \leq L_B|x - y|, \quad (2.3)$$

where L_f , L_B , and κ are some positive constants. In addition, assume that the following equality (the Frobenius condition) holds for all admissible t and x :

$$\sum_{\nu=1}^n \frac{\partial b_{ij}(t, x)}{\partial x_\nu} b_{\nu l}(t, x) = \sum_{\nu=1}^n \frac{\partial b_{il}(t, x)}{\partial x_\nu} b_{\nu j}(t, x), \quad i \in \overline{1, n}, \quad j, l \in \overline{1, m}.$$

Then, for every vector function $v(t)$ satisfying the above conditions, there exists an approximable solution $x(t)$ to the Cauchy problem (2.1) that satisfies the integral equation

$$\begin{aligned}
 x(t) &= x^0 + \int_{t_0}^t f(\xi, x(\xi)) d\xi + \int_{t_0}^t B(\xi, x(\xi)) dv^c(\xi) \\
 &+ \sum_{t_i \leq t, t_i \in \Omega_-} S(t_i, x(t_i - 0), \Delta v(t_i - 0)) + \sum_{t_i < t, t_i \in \Omega_+} S(t_i, x(t_i), \Delta v(t_i + 0)),
 \end{aligned}
 \tag{2.4}$$

where

$$\begin{aligned}
 S(t, x, \Delta v) &= z(1) - x, \\
 \dot{z}(\xi) &= B(t, z(\xi))\Delta v(t), \quad z(0) = x,
 \end{aligned}
 \tag{2.5}$$

and $\Omega_-(\Omega_+)$ is the set left-side discontinuity (right-side discontinuity) points of the vector function $v(t)$,

$$\Delta v(t - 0) = v(t) - v(t - 0), \quad \Delta v(t + 0) = v(t + 0) - v(t).$$

Definition 2. We will say that a differential equation (2.1) is Hyers–Ulam–Rassias stable with respect to a function φ (φ is a positive, continuous, and nondecreasing function) on $[t_0, \vartheta]$ if, for every vector function $y \in BV[t_0, \vartheta]$ satisfying the inequality

$$\begin{aligned}
 &\left| y(t) - x_0 - \int_{t_0}^t f(\xi, y(\xi)) d\xi - \int_{t_0}^t B(\xi, y(\xi)) dv^c(\xi) \right. \\
 &\left. - \sum_{t_i \leq t, t_i \in \Omega_-} S(t_i, y(t_i - 0), \Delta v(t_i - 0)) - \sum_{t_i < t, t_i \in \Omega_+} S(t_i, y(t_i), \Delta v(t_i + 0)) \right| \leq \epsilon \varphi(t),
 \end{aligned}
 \tag{2.6}$$

for all $\epsilon > 0$, and every solution to the inequality (2.6), there exists a positive real number $c_{f,\varphi}$ and a solution to the equation (2.1) $x(t)$ satisfying the inequality

$$|y(t) - x(t)| < c_{f,\varphi} \epsilon \varphi(t)$$

for all $t \in [t_0, \vartheta]$.

3. Main result

Theorem 2. Let the conditions of Theorem 1 be satisfied. Then the differential equation (2.1) is Hyers–Ulam–Rassias stable.

P r o o f. Let $y(t) \in BV[t_0, \vartheta]$ be the solution to inequality (2.6), and let $x(t)$ be the solution to equation (2.4). According to (2.4),

$$\begin{aligned}
 |y(t) - x(t)| &= \left| y(t) - x^0 - \int_{t_0}^t f(\xi, x(\xi)) d\xi - \int_{t_0}^t B(\xi, x(\xi)) dv^c(\xi) \right. \\
 &\left. - \sum_{t_i \leq t, t_i \in \Omega_-} S(t_i, x(t_i - 0), \Delta v(t_i - 0)) - \sum_{t_i < t, t_i \in \Omega_+} S(t_i, x(t_i), \Delta v(t_i + 0)) \right|.
 \end{aligned}$$

We add and subtract the following sum under the modulus on the right-hand side of this relation:

$$\begin{aligned} & \int_{t_0}^t f(\xi, y(\xi)) d\xi + \int_{t_0}^t B(\xi, y(\xi)) dv^c(\xi) + \sum_{t_i \leq t, t_i \in \Omega_-} S(t_i, y(t_i - 0), \Delta v(t_i - 0)) \\ & + \sum_{t_i < t, t_i \in \Omega_+} S(t_i, y(t_i), \Delta v(t_i + 0)). \end{aligned}$$

After grouping and taking into account the properties of the modulus, we obtain

$$\begin{aligned} |y(t) - x(t)| & \leq \left| y(t) - x^0 - \int_{t_0}^t f(\xi, y(\xi)) d\xi - \int_{t_0}^t B(\xi, y(\xi)) dv^c(\xi) \right. \\ & \left. S(t_i, y(t_i - 0), \Delta v(t_i - 0)) - \sum_{t_i < t, t_i \in \Omega_+} S(t_i, y(t_i), \Delta v(t_i + 0)) \right| \\ & + \left| \int_{t_0}^t (f(\xi, y(\xi)) - f(\xi, x(\xi))) d\xi \right| + \left| \int_{t_0}^t (B(\xi, y(\xi)) - B(\xi, x(\xi))) dv^c(\xi) \right| \\ & + \left| \sum_{t_i \leq t, t_i \in \Omega_-} S(t_i, y(t_i - 0), \Delta v(t_i - 0)) + \sum_{t_i < t, t_i \in \Omega_+} S(t_i, y(t_i), \Delta v(t_i + 0)) \right. \\ & \left. - \sum_{t_i \leq t, t_i \in \Omega_-} S(t_i, x(t_i - 0), \Delta v(t_i - 0)) - \sum_{t_i < t, t_i \in \Omega_+} S(t_i, x(t_i), \Delta v(t_i + 0)) \right|. \end{aligned} \quad (3.1)$$

Using the definition of the Stieltjes integral and assumption (2.3), it is not difficult to verify the validity of the inequality

$$\left| \int_{t_0}^t (B(\xi, y(\xi)) - B(\xi, x(\xi))) dv^c(\xi) \right| \leq \int_{t_0}^t L_B |y(s) - x(s)| d \operatorname{var}_{[t_0, s]} v^c(\cdot). \quad (3.2)$$

From inequality (3.1), given assumptions (2.3), and inequality (3.2), we get

$$\begin{aligned} |y(t) - x(t)| & \leq \left| y(t) - x^0 - \int_{t_0}^t f(\xi, y(\xi)) d\xi - \int_{t_0}^t B(\xi, y(\xi)) dv^c(\xi) \right. \\ & \left. - \sum_{t_i \leq t, t_i \in \Omega_-} S(t_i, y(t_i - 0), \Delta v(t_i - 0)) - \sum_{t_i < t, t_i \in \Omega_+} S(t_i, y(t_i), \Delta v(t_i + 0)) \right| \\ & + \left| \int_{t_0}^t L_f |y(\xi) - x(\xi)| d\xi \right| + \left| \int_{t_0}^t L_B |y(\xi) - x(\xi)| d \operatorname{var}_{[t_0, \xi]} v^c(\xi) \right| \\ & + \left| \sum_{t_i \leq t, t_i \in \Omega_-} S(t_i, y(t_i - 0), \Delta v(t_i - 0)) - \sum_{t_i \leq t, t_i \in \Omega_-} S(t_i, x(t_i - 0), \Delta v(t_i - 0)) \right| \\ & + \left| \sum_{t_i < t, t_i \in \Omega_+} S(t_i, y(t_i), \Delta v(t_i + 0)) - \sum_{t_i < t, t_i \in \Omega_+} S(t_i, x(t_i), \Delta v(t_i + 0)) \right|. \end{aligned}$$

From the above chain of inequalities, taking into account (2.6), we obtain

$$|y(t) - x(t)| \leq \varepsilon \varphi(t) + \int_{t_0}^t L_f |y(\xi) - x(\xi)| d\xi + \int_{t_0}^t L_B |y(\xi) - x(\xi)| d \operatorname{var}_{[t_0, \xi]} v^c(\cdot)$$

$$\begin{aligned}
 & + \left| \sum_{t_i \leq t, t_i \in \Omega_-} S(t_i, y(t_i - 0), \Delta v(t_i - 0)) - \sum_{t_i \leq t, t_i \in \Omega_-} S(t_i, x(t_i - 0), \Delta v(t_i - 0)) \right| \\
 & + \left| \sum_{t_i < t, t_i \in \Omega_+} S(t_i, y(t_i), \Delta v(t_i + 0)) - \sum_{t_i < t, t_i \in \Omega_+} S(t_i, x(t_i), \Delta v(t_i + 0)) \right|.
 \end{aligned} \tag{3.3}$$

According to definition (2.5) of the function $S(t, y, \Delta v)$, the following equality holds:

$$\begin{aligned}
 & |S(t_i, y(t_i - 0), \Delta v(t_i - 0)) - S(t_i, x(t_i - 0), \Delta v(t_i - 0))| \\
 & = |z_y(1) - y(t_i - 0) - (z_x(1) - x(t_i - 0))| \\
 & = \left| \int_0^1 (B(t_i - 0, z_y(s)) - B(t_i - 0, z_x(s))) \Delta v(t_i - 0) ds \right|.
 \end{aligned}$$

Hence, using property (2.3), we obtain the inequality

$$|z_y(1) - y(t_i - 0) - (z_x(1) - x(t_i - 0))| \leq \int_0^1 L_B |\Delta v(t_i - 0)| |z_y(s) - z_x(s)| ds.$$

Adding and subtracting $y(t_i - 0) - x(t_i - 0)$ under the modulus in the integral and then applying the triangle inequality to this modulus, we get

$$\begin{aligned}
 & |z_y(1) - y(t_i - 0) - (z_x(1) - x(t_i - 0))| \leq L_B |\Delta v(t_i - 0)| |y(t_i - 0) - x(t_i - 0)| \\
 & + \int_0^1 L_B |\Delta v(t_i - 0)| |z_y(s) - y(t_i - 0) - (z_x(s) - x(t_i - 0))| ds.
 \end{aligned} \tag{3.4}$$

Using Gronwall’s lemma in (3.4), we get

$$|z_y(1) - y(t_i - 0) - (z_x(1) - x(t_i - 0))| \leq L_B |\Delta v(t_i - 0)| |y(t_i - 0) - x(t_i - 0)| e^{L_B |\Delta v(t_i - 0)|}. \tag{3.5}$$

On the right-hand side of (3.5), we use the obvious inequality $ae^b \leq e^{ab} - 1$, $a > 0$, $b \geq e$, which can be easily proved by means of the Taylor expansion of the exponent and the inequality $b^n > n$ for $b \geq e$. As a result, we obtain

$$|z_y(1) - y(t_i - 0) - (z_x(1) - x(t_i - 0))| \leq |y(t_i - 0) - x(t_i - 0)| (e^{eL_B |\Delta v(t_i - 0)|} - 1). \tag{3.6}$$

It is clear that a similar inequality can also be obtained at the point $(t_i + 0)$.

Estimating the differences of the sums in (3.3) with the use of (3.6), we obtain the inequality

$$\begin{aligned}
 |y(t) - x(t)| & \leq \varepsilon \varphi(t) + \int_{t_0}^t L_f |y(\xi) - x(\xi)| d\xi + \int_{t_0}^t L_B |y(\xi) - x(\xi)| d \operatorname{var}_{[t_0, \xi]} v^c(\xi) \\
 & + \sum_{t_i \leq t, t_i \in \Omega_-} |y(t_i - 0) - x(t_i - 0)| (e^{eL_B |\Delta v(t_i - 0)|} - 1) \\
 & + \sum_{t_i < t, t_i \in \Omega_+} |y(t_i) - x(t_i)| (e^{eL_B |\Delta v(t_i + 0)|} - 1).
 \end{aligned} \tag{3.7}$$

Inequality (3.7) obviously implies the inequality

$$|y(t) - x(t)| \leq \varepsilon\varphi(t) + \int_{t_0}^t \max\{L_f; L_B\} |y(\xi) - x(\xi)| d(\xi + \operatorname{var}_{[t_0, \xi]} v^c(\cdot))$$

$$+ \sum_{t_i \leq t, t_i \in \Omega_-} |y(t_i - 0) - x(t_i - 0)| (e^{eL_B|\Delta v(t_i-0)|} - 1) + \sum_{t_i < t, t_i \in \Omega_+} |y(t_i) - x(t_i)| (e^{eL_B|\Delta v(t_i+0)|} - 1).$$

Applying an estimate from [11, p. 192], we get

$$|y(t) - x(t)| \leq \varepsilon\varphi(t)e^{H(t)},$$

where

$$H(t) = \max\{L_f; L_B\} \left(t - t_0 + \operatorname{var}_{[t_0, t]} v^c(\xi) + \sum_{t_i \leq t, t_i \in \Omega_-} |\Delta v(t_i - 0)| + \sum_{t_i \leq t, t_i \in \Omega_+} |\Delta v(t_i + 0)| \right).$$

Taking into account that $H(t)$ is a monotonically increasing function, we set $c_{f\varphi} = H(\vartheta)$, which completes the proof of the theorem. \square

4. Conclusion

The paper presents a formalization of the concept of the Hyers–Ulam–Rassias stability for nonlinear systems of differential equations with a generalized action on the right-hand side. Sufficient conditions are obtained that ensure such stability.

REFERENCES

1. Hyers D. H. On the stability of the linear functional equation. *Proc. Natl. Acad. Sci. USA*, 1941. Vol. 27, No. 4. P. 222–224. DOI: [10.1073/pnas.27.4.222](https://doi.org/10.1073/pnas.27.4.222)
2. Miller B. M., Rubinovich E. Y. Discontinuous solutions in the optimal control problems and their representation by singular space-time transformations. *Autom. Remote Control*, 2013. Vol. 74, No. 12. P. 1969–2006. DOI: [10.1134/S0005117913120047](https://doi.org/10.1134/S0005117913120047)
3. Pavlenko V., Sesekin A.. Ulam–Hyers Stability of First and Second Order Differential Equations with Discontinuous Trajectories. In: *Proc. 2022 16th Int. Conf. on Stability and Oscillations of Nonlinear Control Systems (Pyatnitskiy's Conference 2022)*. V.N. Tkhai (ed.). IEEE Xplore, 2022. P. 1–4. DOI: [10.1109/STAB54858.2022.9807520](https://doi.org/10.1109/STAB54858.2022.9807520)
4. Popa D. Hyers–Ulam–Rassias stability of a linear recurrence. *J. Math. Anal. Appl.*, 2005. Vol. 309, No. 2. P. 591–597. DOI: [10.1016/j.jmaa.2004.10.013](https://doi.org/10.1016/j.jmaa.2004.10.013)
5. Rassias Th. M. On the stability of the linear mapping in Banach spaces. *Proc. Amer. Math. Soc.*, 1978. Vol. 72, No. 2. P. 297–300. DOI: [10.2307/2042795](https://doi.org/10.2307/2042795)
6. Rus I. A. Ulam stability of ordinary differential equations. *Stud. Univ. Babeş-Bolyai Math.*, 2009. Vol. 54, No. 4. P. 125–133.
7. Samoilenko A. M., Perestyuk N. A. *Impulsive Differential Equations*. World Sci. Ser. Nonlinear Sci. Ser. A, vol. 14. River Edge, NJ: World Sci. Publ. Co. Inc., 1995. 472 p. DOI: [10.1142/2892](https://doi.org/10.1142/2892)
8. Sesekin A.N. Dynamic systems with nonlinear impulse structure. *Proc. Steklov Inst. Math.*, 2000. Suppl. 2. P. S158–S172.
9. Wang J. R., Fečkan M., Zhou Y. Ulam's type stability of impulsive ordinary differential equations. *J. Math. Anal. Appl.*, 2012. Vol. 395, No. 1. P. 258–264. DOI: [10.1016/j.jmaa.2012.05.040](https://doi.org/10.1016/j.jmaa.2012.05.040)
10. Zada A., Riaz U., Khan F. U. Hyers–Ulam stability of impulsive integral equations. *Boll. Unione. Mat. Ital.*, 2019. Vol. 12. P. 453–467. DOI: [10.1007/s40574-018-0180-2](https://doi.org/10.1007/s40574-018-0180-2)
11. Zavalishchin S. T., Sesekin A. N. *Dynamic Impulse Systems: Theory and Applications*. Dordrecht: Kluwer Academic Publishers, 1997. 256 p. DOI: [10.1007/978-94-015-8893-5](https://doi.org/10.1007/978-94-015-8893-5)

THE MINIMAL DOMINATING SETS IN A DIRECTED GRAPH AND THE KEY INDICATORS SET OF SOCIO-ECONOMIC SYSTEM¹

Ruslan Yu. Simanchev^{a,b,†}, Inna V. Urazova^{a,††}, Vladimir V. Voroshilov^{a,†††}

^aDostoevsky Omsk State University,
Prospect Mira 55a, Omsk, 644077, Russia

^bOmsk Scientific Center of SB RAS,
Prospect K. Marksa 15, Omsk, 644024, Russia

[†]osiman@rambler.ru ^{††}urazovainn@mail.ru ^{†††}voroshil@gmail.com

Abstract: The paper deals with a digraph with non-negative vertex weights. A subset W of the set of vertices is called dominating if any vertex that not belongs to it is reachable from the set W within precisely one step. A dominating set is called minimal if it ceases to be dominating when removing any vertex from it. The paper investigates the problem of searching for a minimal dominating set of maximum weight in a vertex-weighted digraph. An integer linear programming model is proposed for this problem. The model is tested on random instances and the real problem of choosing a family of key indicators in a specific socio-economic system. The paper compares this model with the problem of choosing a dominating set with a fixed number of vertices.

Keywords: Combinatorial Optimization, Boolean programming, Minimal dominating set, Key indicators.

1. Introduction

Let G be a directed graph with a vertex set V and an arc set E , $|V| = n$. Denote by ij the arc from a vertex i to a vertex j of the digraph G . A set $W \subseteq V$ is called dominating if, for every vertex $j \in V \setminus W$, there is a vertex $i \in W$ such that $ij \in E$. A dominating subset $W \subseteq V$ is called minimal dominating if none of its proper subsets is dominating. The problem of finding a minimal dominant set of maximum cardinality (Upper Domination) is widely known. In [3], its NP -hardness for the case of an undirected graph was proven. This quickly leads to the NP -hardness in the case of a directed graph. Some classes of graphs on which Upper Domination is polynomially solvable are known. This concerns those graphs on which the maximum cardinality of the minimal dominating set coincides with the independence number (for example, bipartite graphs), and the independence number for graphs of these classes can be computed in polynomial time. In addition to bipartite graphs [4], Upper Domination is polynomially solvable for chordal graphs [7], generalized series-parallel graphs [6], and graphs with bounded clique-width [5]. Much attention has recently been paid to the approximation properties of this problem. For example, in [2], it is shown that Upper Domination does not allow for $n^{1-\epsilon}$ approximation for any $\epsilon > 0$ unless $P = NP$. This makes Upper Domination significantly harder than the problem of the dominating set (without the condition of minimality) with the cardinality, which is bounded from above. We consider a weighted Upper Domination on a directed graph with positive vertex weights, which we will call the Weight MinDom Problem (WMDP). We are interested in using an integer linear program to find an exact solution to the problem. Let us denote the families of all dominating and

¹This work was carried out within the governmental order for Omsk Scientific Center of SB RAS (project registration number 121022000112-2).

minimal dominating sets in the digraph G by $I(G)$ and $I_m(G)$, respectively. Let $c_i > 0$, $i \in V$, be weights of vertices P of the graph G . By the weight of the subset $S \subseteq V$, we mean the number $c(S) = \sum_{i \in S} c_i$. In this notation, the combinatorial setting of the WMDP takes the form: find $W^* \in I_m(G)$ such that $c(W^*) \geq c(W)$ for any $W \in I_m(G)$. We will associate the vertex set V of the digraph G with the Euclidean space \mathbb{R}^V by the one-to-one correspondence between the elements of the set V and the coordinate axes of the space \mathbb{R}^V . In other words, \mathbb{R}^V is the space of column vectors whose components are indexed by elements of the set V . For every $S \subseteq V$ we consider its incidence vector $x^S \in \mathbb{R}^V$ with the coordinates $x_i^S = 1$ for $i \in S$ and $x_i^S = 0$ for $i \notin S$. We define the polytopes of dominating sets and minimal dominating sets as

$$P(G) = \text{conv}\{x^W \in \mathbb{R}^V \mid W \in I(G)\}$$

and

$$P_m(G) = \text{conv}\{x^W \in \mathbb{R}^V \mid W \in I_m(G)\},$$

respectively. Here conv means the convex hull. Note that if $c \in \mathbb{R}^V$ is a column vector with components c_i , then the following equalities are true for all $S \subseteq V$:

$$\sum_{i \in S} c_i = \sum_{i \in V} c_i x_i^S = c^T x^S,$$

where T is the transpose sign. Thus, the WMDP can be considered in the polyhedral setting as the problem of maximizing the linear function $c^T x$ on the vertex set of the polytope $P_m(G)$.

In this paper, we obtain the following results. First, the nonlinear characterization of minimal dominating sets is extended from the case of an undirected graph to a directed graph. Second, a linear integer programming model is constructed for the problem under consideration. This model requires the introduction of additional variables different from the variables of the space \mathbb{R}^V . This increases the dimension of the problem but allows us to formalize the condition of minimality of dominating sets in terms of linear inequalities. Third, we propose an ILP model for the approximate solution to the problem. This model is defined by replacing the minimality condition of the dominating set with the fixation of its cardinality. Since the power of the dominating set does not exceed n , we can use enumeration by cardinality. This increases the number of ILP problems to be solved. But, as the computational experiment shows, the time to solve each of them is significantly shorter than that of the original exact model.

The paper is structured as follows: Section 2 contains a nonlinear model in the space \mathbb{R}^V that describes the set of incidence vectors of minimal dominating sets; Section 3 contains a Boolean linear programming model for the WMDP; Section 4 contains a description of the applied problem of the key indicators system, a brief overview of the results of the research conducted by economists, and the ways to formalize this problem in terms of WMDP; Section 5 presents the results of a numerical experiment.

2. Nonlinear characterization of minimal dominating sets

For every vertex $i \in V$, define

$$N_-[i] = \{j \in V \mid ji \in E\} \cup \{i\},$$

$$N_+[i] = \{j \in V \mid ij \in E\} \cup \{i\}.$$

In this notation, the dominating set in a graph G is a set $W \subseteq V$ such that the condition $N_-[i] \cap W \neq \emptyset$ is satisfied for each vertex $i \in V$.

Lemma 1. *The dominating set W in a digraph G is minimal if and only if, for every vertex $i \in W$, there exists a vertex $j \in N_+[i]$ such that $N_-[j] \cap W = \{i\}$.*

P r o o f. Necessity. Let W be the minimal dominating set. Let us suppose that there exists a vertex $k \in W$ such that $N_-[j] \cap W \neq \{k\}$ for all $j \in N_+[k]$. Since the vertex k obviously belongs to both sets $N_-[j]$ and W , this assumption means that their intersection contains at least one more vertex in addition to the vertex k . Consequently, for every vertex $j \in N_+[k]$, the set $(N_-[j] \cap W) \setminus \{k\}$ is nonempty. Let us prove that the set $W' = W \setminus \{k\}$ is dominating. It must be shown that the condition $N_-[j] \cap W' \neq \emptyset$ holds for all $j \in V \setminus W'$. It is clear that $V \setminus W' = (V \setminus W) \cup \{k\}$. If $j = k$, then in view of that $k \in N_+[k]$ and the assumption made, we have $N_-[k] \cap W' \neq \emptyset$. Assume that $j \in V \setminus W$. If $j \in N_+[k]$, then, as it is shown above, $N_-[j] \cap W' = (N_-[j] \cap W) \setminus \{k\} \neq \emptyset$. Finally, according to the definition of the dominating set, if $j \notin N_+[k]$, then it is reachable from a vertex of the set W different from k . Thus, the set $W' = W \setminus \{k\}$ is dominating, which contradicts the minimality of the dominating set W .

Sufficiency. We will show that no single vertex of the set W can be discarded without losing the dominance property. Take an arbitrary vertex $k \in W$ and consider the set $W' = W \setminus \{k\}$. Since $k \in W$, by the assumption, there is a vertex $j \in N_+[k]$ such that $N_-[j] \cap W = \{k\}$. Then $N_-[j] \cap W' = (N_-[j] \cap W) \setminus \{k\}$, which means that the set W' is not dominating. Hence, due to the arbitrariness of the vertex $k \in W$, the set W is a minimal dominating one.

The lemma is proved. □

It is easy to see that an integer vector $x \in \mathbb{R}^V$ is an incidence vector of a dominating set (without the minimality condition) if and only if it satisfies the constraints

$$\sum_{j \in N_-[i]} x_j \geq 1, \quad i \in V, \tag{2.1}$$

$$0 \leq x_i \leq 1, \quad i \in V. \tag{2.2}$$

The following theorem immediately follows from Lemma 1.

Theorem 1. *An integer vector $x \in \mathbb{R}^V$ satisfying conditions (2.1)–(2.2) is an incidence vector of a minimal dominating set if and only if it satisfies the system of constraints*

$$x_i \cdot \prod_{j \in N_+[i]} (1 - \sum_{k \in N_-[j]} x_k) = 0, \quad i \in V.$$

In [3], a similar characterization of minimal dominating sets without the condition of the directivity of the original graph was described.

3. Linear integer model

To use integer linear programming, first of all, it is necessary to have good polyhedral relaxation of the polytope $P_m(G)$. Under “good” polyhedral relaxation, we mean a system of linear equations and inequalities in the space \mathbb{R}^V whose integer solutions are no other but all vertices of the polytope $P_m(G)$. It is easy to see that, for the polytope $P(G)$ of dominating sets without the minimality condition, the polyhedral relaxation satisfying these requirements is the polyhedron $M(G)$ defined by the constraints (2.1)–(2.2). For this polyhedron, we will also use the matrix notation

$$M(G) = \{x \in \mathbb{R}^V \mid Ax \geq 1, 0 \leq x \leq 1\},$$

where A is an $(n \times n)$ -matrix with coefficients $a_{ji} = 1$ for $j \in N_-[i]$ and $a_{ji} = 0$ in other cases. Since $P_m(G)$ is obviously a subset of the polyhedron $M(G)$, we can consider the polyhedron $M(G)$ to be a relaxation of minimal dominating sets polytope. However, $M(G)$ contains incidence vectors of all dominating sets, including those that do not have the minimality property. We will construct a system of linear equations and inequalities that will allow us to formalize the WMDP as a Boolean linear programming problem. The model will use additional variables $y_{ij} \in \{0, 1\}$, $i, j = 1, 2, \dots, n$.

Theorem 2. *The system of inequalities with respect to variables $x_k, y_{ik} \in \{0, 1\}$, $i, k = 1, 2, \dots, n$,*

$$\sum_{j=1}^n a_{ij}x_j \geq 1, \quad i = 1, 2, \dots, n, \quad (3.1)$$

$$\sum_{i=1}^n y_{ik} - x_k \geq 0, \quad i = 1, 2, \dots, n, \quad (3.2)$$

$$\sum_{j=1}^n a_{ij}x_j - a_{ik}x_k \leq n(1 - y_{ik}), \quad i, k = 1, 2, \dots, n, \quad (3.3)$$

$$x_k, y_{ik} \in \{0, 1\}, \quad i, k = 1, 2, \dots, n, \quad (3.4)$$

has a solution if and only if the $(0, 1)$ -vector x is the incidence vector of the minimal dominating set of the graph G .

P r o o f. Let (x, y) be a solution of system (3.1)–(3.4). By constraints (3.1), the vector x is an incidence vector of a set $W \in I(G)$. Assume that $W \notin I_m(G)$. Then there is $k \in W$ such that $W \setminus \{k\} \in I(G)$. This means that constraints (3.1) are also satisfied for the vector $x^{W \setminus \{k\}}$. This and constraints (3.3) result in that

$$n(1 - y_{ik}) \geq \sum_{j=1}^n a_{ij}x_j^W - a_{ik}x_k^W = \sum_{j=1}^W a_{ij}x_j^{W \setminus \{k\}} \geq 1,$$

for all $i = 1, 2, \dots, n$. Hence, $y_{ik} = 0$. However, (3.2) implies

$$\sum_{i=1}^n y_{ik} \geq x_k^W = 1,$$

a contradiction. Now let $W \in I_m(G)$. Define the following values of the variables y_{ik} for $i, k = 1, 2, \dots, n$:

$$y_{ik} = \begin{cases} 0 & \text{if } k \notin W; \\ 0 & \text{if } k \in W \text{ and } \sum_{j=1}^n a_{ij}x_j^W - a_{ik}x_k^W \geq 1; \\ 1 & \text{if } k \in W \text{ and } \sum_{j=1}^n a_{ij}x_j^W - a_{ik}x_k^W < 1. \end{cases}$$

We will show that the pair (x^W, y) is a solution to system (3.1)–(3.4). Inequalities (3.1) hold because $W \in I_m(G)$. Inequality (3.3) is always true for $y_{ik} = 0$ and holds for $y_{ik} = 1$ by construction. Inequalities (3.2) are obviously true for all $x_k^W = 0$. Let us show that they are also true for $x_k^W = 1$. Since $W \in I_m(G)$, we have $x^{W \setminus \{k\}} \notin I_m(G)$. Therefore, for all $k \in W$, there exists $l \in \{1, 2, \dots, n\}$ such that

$$\sum_{j=1}^n a_{lj}x_j^W - a_{lk}x_k^W = \sum_{j=1}^n a_{lj}x_j^{W \setminus \{k\}} = 0.$$

Then $y_{lk} = 1$ by construction. Therefore, for all $x_k^W = 1$, we have

$$\sum_{i=1}^n y_{ik} - x_k^W \geq y_{lk} - x_k^W = 0.$$

The proof is complete. \square

Thus, the integer formulation of the WMDP is to maximize the function $c(x) = c^T x$ under conditions (3.1)–(3.4).

4. Practical application for key indicators problem

Recently, in data analysis, an approach based on selecting a specific subset from a large number of indicators has been used. Using this subset of indicators, we can conclude the state of the whole system. This subset, as a rule, should fully reflect the state of the system, have a high sensitivity to the changes in the situation, and interact with other indicators to a sufficiently strong degree. In other words, we distinguish some “key” indicators from the list of indicators. In modern economic science, when analyzing the state of the regional economy, much attention is paid to creating an indicative evaluation system. This approach is based on the selection of a system of key indicators and the analysis of their values. The number of approaches to the formation of key indicator systems grows with each new publication (see, for example, [8–10, 12], etc.). However, the ambiguity of the proposed formulations, the methodological inconsistency of concepts, and especially the lack of a sound methodology for calculating the numerical characteristics make it difficult, in our opinion, to build an objective concept of an indicative assessment of the economic situation. In the literature on economics, the criteria for selecting these limited indicators set are not clear. In this case, when analyzing the existing systems of key indicators, we again come across the opinions of the experts, the number of which often prevail over the number of indicators themselves. We propose to consider the minimal dominating sets of a special graph associated with the economic system as key indicator systems. We are far from thinking that this approach is the best. It should be considered as a means applicable for a certain range of situations, as an element of a hybrid analysis of not only the economic condition but also a wider range of tasks. In [1, 11] there is a comparison of different key indicator systems of economic security, among which there is a system obtained in the framework of our approach.

So, let $V = \{1, 2, \dots, n\}$ be a particular set of indicators given a priori, for each of which there are a technique for calculating its value at each given moment in time and a set of these values for a certain period (several years, months, days, etc.). We believe that the statistics available allow us to calculate the sample correlation coefficients $k(i, j)$ between any pair of indicators $i, j \in V$. We will introduce two additional considerations to the correlation matrix. First, from a practical point of view, the value of the correlation coefficient may turn out to be so small that the dependence on the corresponding indicators can be neglected. In this regard, as a control parameter of the model, we introduce the value α — the dependence threshold — thus assuming that if $|k(i, j)| < \alpha$, then $|k(i, j)| = 0$. Second, if there is a relationship between the two indicators in terms of a causal relationship, the following alternative is important: “ i determines j ” or “ j determines i .” For example, if the random variable i is the number of fires in the village, and j is the number of fire brigade visits during the same period, then it is clear that “ i determines j ” and not vice versa. Such a causal relationship is denoted by $i \rightarrow j$. Nevertheless, in some cases, a situation is possible where the primary and secondary indicators cannot be determined, or they are interdependent. In such cases, we will write $i \leftrightarrow j$, which, basically, is equivalent to a pair of conditions $i \rightarrow j$ and $j \rightarrow i$. As a result, for any chosen dependence threshold α , we will fix the correlation matrix $K(\alpha)$.

Now we will associate our set of exponents V and the correlation matrix $K(\alpha)$ with the directed graph G_α , the vertex set of which is the set of indicators V , and the set of arcs E is defined as follows: from i to j there is an arc if and only if $|k(i, j)| \geq \alpha$ and $i \rightarrow j$. The graph G_α is called the α -correlation graph of the set of indicators under consideration. A subset $W \subseteq V$ is called a key indicators system if W is a minimal dominating set in the graph G_α . In this approach, an important feature of a key indicators system is that the indicators belonging to the system are key ones only in the aggregate. This consideration becomes more noticeable because, in general, there are many minimal dominating sets in a graph. We will define the weight (degree of influence) of the indicator i as

$$c_i = \sum_{j \in V | ij \in E} |k(i, j)|$$

and the weight of the subset $S \subseteq V$ as

$$c(S) = \sum_{i \in S} c_i.$$

5. Numerical experiment

Using the constructed WMDP model in numerical experiments on random data, we noticed that, for a relatively large dimension ($n > 60$), it takes too much time to solve the problem (more than 3 hours). We used a computer Intel(R) Celeron(R) CPU N2830 2.16GHz and the commercial package IBM ILOG CPLEX Optimization Studio 12.10. Initially, the interest in the problem of the minimal dominating set of maximum weight was caused by the problem of finding a system of key indicators among some a priori given set of indicators of economic security discussed in the previous section. These indicators and their values were withdrawn from the website of the Federal State Statistics Service of the Russian Federation. Their number is estimated at several hundred. In this regard, a question arose of using additional considerations that would allow us to find acceptable solutions to practical problems in a reasonable time.

To achieve this goal, we consider one more model for choosing a system of key indicators. We discard the minimality condition of the dominating sets and replace this condition with a search for the maximum weight of the dominating set of a given cardinality. From an economic point of view, this approach also makes sense. It is true that when distinguishing a system of key indicators at a practical level, two basic considerations are important. Firstly, there should be relatively few key indicators and, secondly, they should have a significant impact on the situation. For this, in principle, the dominance condition is sufficient. The number of key indicators can be considered as an external condition. Under this assumption, the problem is formalized as a Boolean programming problem of the following form

$$\max \left\{ c^T x \mid Ax \geq 1, \sum_{i=1}^n x_i = h, x \in \{0, 1\}^V \right\}. \quad (5.1)$$

We will denote such a problem by $WDP(h)$. In this approach, we can solve a series of $WDP(h)$ problems by decreasing the value of the h parameter until the problem ceases to have a solution. It is clear that, in this case, we also get the minimal dominating set of the least cardinality. However, it remains an open question, whether it will be the minimum dominating set of maximum weight. Since the dimension of $WDP(h)$ is less than the dimension of WMDP, this approach may be computationally less time-consuming than using the WMDP model directly. In this regard, our computational experiment has the following objectives.

1. Evaluation of solutions obtained using the $WDP(h)$ procedure. The comparison is carried out both in terms of the weight and power of the obtained obtained.
2. The behavior of the $WDP(h)$ procedure concerning the structural properties of the digraph G .

We will use the following notation:

$WDP(h)$ — the procedure based on a monotonic decrease in the values of the parameter h in the model (5.1). The procedure ends when $WDP(h)$ has a solution, and $WDP(h-1)$ does not have one;

WMDP — the model (3.1)–(3.4) with the objective function $f(x) = c^T x$;

$f1, h1$ — the optimal value of the objective function in the $WDP(h)$ procedure and the cardinality of the optimal solution, respectively;

$f2, h2$ — the optimal value of the objective function in the WMDP and the cardinality of the optimal solution, respectively;

$\Delta = \frac{f2 - f1}{f2}$ — the relative error of the $WDP(h)$ procedure;

$\frac{h1}{h2}$ — the ratio of cardinalities of optimal solutions in $WDP(h)$ and WMDP;

$time1, time2$ — the time to solve the problem by the $WDP(h)$ and WMDP algorithms, respectively (in minutes);

$\rho = \frac{|E|}{n^2 - n}$ — the density of the digraph G ;

α — the dependence threshold (see Section 4).

The comparison was carried out on ten problems with random data. For each problem, the input correlation matrix was $K(0)$ for $n = 40$. From the matrix $K(0)$, $K(\alpha)$ problems were obtained for $\alpha = 0.2, 0.4, 0.5, 0.7, 0.8$. The objective function was formed by the formula

$$c_i = \sum_{j \in V | ij \in E} |k(i, j)|,$$

where $k(i, j) \in [-1, 1]$ are the coefficients of the corresponding matrix $K(\alpha)$. As a result, for each value of α , we got ten problems with random input data. As mentioned above, to solve the integer linear programming problems arising in the experiment, we used the IBM ILOG CPLEX Optimization Studio 12.10 package.

Table 1 shows the average values (for ten instances) of the above parameters for each α .

As we can see, with an increase in the dependence threshold, the characteristics Δ and $(h1/h2)$ of $WDP(h)$ procedure improve. However, it should be noted that, with the growth of α , the weights of optimal solutions to WMDP problems decrease. This is important for the key indicators problem since the weight of the found dominating set characterizes the degree of its influence on the set of indicators as a whole. In this regard, it is advisable to choose α equal to 0.7 or 0.8.

In addition to these problems on 40 vertices, ten instances on 50 vertices with $\alpha = 0.7$ were considered. The relative error and the ratio of cardinalities of optimal solutions turned out to be comparable with a similar situation for $n = 40$. However, the average time to solve these ten instances using WMDP was 46 minutes. Problems with $n > 70$ and $\alpha = 0.7$ were not resolved in 3 hours.

And finally, the third observation. As mentioned above, we withdrew 63 indicators of economic security characterizing the socio-economic situation in the Omsk region of Russia from the website of the Federal State Statistics Service of the Russian Federation. The correlation coefficients were calculated for the period of 2010–2017. These indicators and the rationale for their choice are

Table 1. Comparison of the WDP(h) and WMDP procedures in terms of time, relative error, and the ratio of cardinalities of optimal solutions for $n = 40$.

α	ρ_{med}	$(time2)_{med}$	$(time1)_{med}$	Δ_{med}	$(h1/h2)_{med}$
0.2	0.43	3.56	0.02	0.44	0.48
0.4	0.32	3.81	0.03	0.5	0.44
0.5	0.27	3.99	0.04	0.47	0.46
0.7	0.16	2.46	0.03	0.39	0.53
0.8	0.11	0.99	0.02	0.31	0.61

Table 2. The results of solving the problems with real data for $n = 63$ and $n = 50$.

n	α	ρ	$time2$	$f2$	$h2$	$time1$	$f1$	$h1$	Δ	$h1/h2$
63	0.7	0.18	0.06	182.5	15	0.04	127.5	11	0.30	0.73
63	0.8	0.12	0.08	126.4	19	0.06	123.7	18	0.02	0.95
50(63)	0.7	0.18	0.08			0.05			0.27	0.79

described in detail in [11]. The problem was solved using the WMDP and WDP(h) models. In the same work, the found key system of indicators was compared with other approaches proposed by various researchers and organizations, including the Economic Security Strategy of the Russian Federation until 2030. As it turned out, the problem with real data on 63 indicators with the use of the WMDP model was solved quite quickly (see Table 2). In addition, to prove the algorithm on real data, 50 indicators (10 samples) were randomly chosen from the given 63 indicators. The average values of the results for these ten samples are also shown in Table 2 (the row titled “50(63)”) ².

Noteworthy that the problems on real data, in contrast to random instances, are quickly solved by using the WMDP model. This observation makes reasonable the further investigation of the minimal dominating set problem.

6. Conclusion

In this paper, we propose an integer linear model of formalizing the problem of a weighted minimal dominating set in a directed graph. This is a generalization of the Upper Domination problem about the minimal dominating set of maximum cardinality in an ordinary graph, which is widely discussed in the works today. A model for an approximate solution to the problem is proposed. This model is based on discarding the minimality condition of the dominant set. An experimental analysis of this approximation is carried out. The average values of relative error estimates are obtained both for the weight and the cardinality of optimal solutions. It is noted that the relative error of the approximate solution decreases with lesser graph density.

As an application of the results obtained, a formalization of a key indicators system concept is proposed. This concept is widely used within the indicator approach to the analysis of socio-economic systems. We define the set of key indicators as a subset of the original set of indicators that has the most significant impact on the situation. Unfortunately, this approach does not exclude the participation of the expert community in selecting key indicators since our algorithms provide more than one solution. We believe that our approach should be considered as an apparatus applicable for a certain range of situations as an element of a hybrid analysis not only for

²Some empty cells in the third row of Table 2 are because this row contains the average values of the results.

economic security but also for a wider range of economic and social problems. The calculations based on real data characterizing the economic security of the Omsk region of the Russian Federation are made. These calculations should be considered primarily as an example of our approach being applied. Implementation-wise, the foundation for the proposed approach is the thesis that the same key indicators system cannot be universal for different socio-economic entities since the deep interconnections between the indicators can have a different nature determined by the territory specifics.

REFERENCES

1. Agalakov A. S., Simanchev R. Yu., Urazova I. V. On the approach to construction of the key indicators system of economic security. *Herald of Omsk University. Ser. Economics*, 2018. No. 4(64). P. 5–12. (in Russian) DOI: [10.25513/1812-3988.2018.4.5-12](https://doi.org/10.25513/1812-3988.2018.4.5-12)
2. Bazgan C. et al. Upper domination: complexity and approximation. In: *Lecture Notes in Comput. Sci., vol. 9843: Combinatorial Algorithms. IWOCA 2016*, Mäkinen V. et al. (eds.). Cham: Springer, 2016. P. 241–252. DOI: [10.1007/978-3-319-44543-4_19](https://doi.org/10.1007/978-3-319-44543-4_19)
3. Cheston G. A., Fricke G., Hedetniemi S. T., Pokrass Jacobs D. On the computational complexity of upper fractional domination. *Discrete Appl. Math.*, 1990. Vol. 27, No. 3. P. 195–207. DOI: [10.1016/0166-218X\(90\)90065-K](https://doi.org/10.1016/0166-218X(90)90065-K)
4. Cockayne E. J., Favaron O., Payan C., Thomason A. G. Contributions to the theory of domination, independence and irredundance in graphs. *Discrete Math.*, 1981. Vol. 33, No. 3. P. 249–258. DOI: [10.1016/0012-365X\(81\)90268-5](https://doi.org/10.1016/0012-365X(81)90268-5)
5. Courcelle B., Makowsky A., Rotics U. Linear time solvable optimization problems on graphs of bounded clique-width. *Theory Comput. Systems*, 2000. Vol. 33, No. 2. P. 125–150. DOI: [10.1007/s002249910009](https://doi.org/10.1007/s002249910009)
6. Hare E. O., Hedetniemi S. T., Laskar R. C., Peters K., Wimer T. Linear-time computability of combinatorial problems on generalized-series-parallel graphs. *Discrete Algorithms and Complexity*, 1987. P. 437–457. DOI: [10.1016/B978-0-12-386870-1.50030-7](https://doi.org/10.1016/B978-0-12-386870-1.50030-7)
7. Jacobson M. S., Peters K. Chordal graphs and upper irredundance, upper domination and independence. *Annals Discrete Math.*, 1991. Vol. 48. P. 59–69. DOI: [10.1016/S0167-5060\(08\)71038-0](https://doi.org/10.1016/S0167-5060(08)71038-0)
8. Korableva A. A., Karpov V. V. Indicators of economic security of the region. *Herald Siberian Inst. Business Inform. Tech.*, 2017. No. 3(23). P. 36–42. (in Russian)
9. Kuznetsov D. A., Rudenko M. N. The system of indicators for evaluating the national economic security. *National Interests: Priorities and Security*, 2015. Vol. 11, No. 23(308). P. 59–68. (in Russian)
10. Loginov K. K. Analysis of indicators of regional economic safety. *The Russian Automobile and Highway Industry J.*, 2015. No. 2(42). P. 132–139. (in Russian)
11. Simanchev R. Yu., Urazova I. V., Voroshilov V. V., Karpov V. V., Korableva A. A. Selection the key indicators system of the region economic security with use of the (0,1)-programming model. *Herald of Omsk University. Ser. Economics*, 2019. Vol. 17, No. 3. P. 170–179. (in Russian) DOI: [10.25513/1812-3988.2019.17\(3\).170-179](https://doi.org/10.25513/1812-3988.2019.17(3).170-179)
12. Vorona-Slivinskaya L. G., Lobanov M. V. Problems in selection of state economic security indicators and parametrization of their threshold characters. *Bull. St. Petersburg University of the State Fire Service of the Ministry of Emergency Situations of Russia*, 2009. No. 4. P. 43–47. (in Russian)

AN $M^{[X]}/G/1$ QUEUE WITH OPTIONAL SERVICE AND WORKING BREAKDOWN

B. Somasudaram[†], S. Karpagam^{††}, R. Lokesh^{†††}, A. Kavin Sagana Mary^{††††}

Vel Tech Rangarajan Dr.Sagunthala R&D Institute of Science and Technology,
Chennai – 600 062, Tamil Nadu, India

[†]somu.b92@gmail.com ^{††}karpagammaths19@gmail.com

^{†††}rlokesh1020@gmail.com ^{††††}kavinmary28@gmail.com

Abstract: In this study, a batch arrival single service queue with two stages of service (second stage is optional) and working breakdown is investigated. When the system is in operation, it may breakdown at any time. During breakdown period, instead of terminating the service totally, it continues at a slower rate. We find the time-dependent probability generating functions in terms of their Laplace transforms and derive explicitly the corresponding steady state results. Furthermore, numerous measures indicating system performances, such as the average queue size and the average queue waiting time, has been obtained. Some of the numerical results and graphical representations were also presented.

Keywords: Non-Markovian queue, Second optional service, Working breakdown.

1. Introduction

Queueing theory refer to the study of people, their object and movement in line. It is working to create a well balanced system that serves customers faster and works efficiently without being too expensive. Queueing is widely performed to analyze and streamline staffing needs, scheduling, and inventory in order to enhance overall customer service. The system may have either a limited or an unlimited capacity for holding customers. The sources from which the customers come may be finite or infinite. Queueing models with a second optional service imply that all arriving consumers will receive the first essential service, while only few will request the second optional service.

Yang and Chen [17] examined $M/M/1$ queueing system which has optional service. The server is assumed to malfunction. Together they derived the condition at which the stability is obtained and have found the probability stationary distribution using Matrix geometric method. A queueing model $M^{[X]}/G/1$ queue with two phases of service was presented by Maragathasundari and Srinivasan [10]. In their study they have clearly analysed the steady state results and some performance measures. Finally, they demonstrated some good applications related to the model such as large scale industrial production lines which also include computer communication networks.

Second optional service with general service time distribution was studied by Al-Jararha and Madan [2]. They used the supplementary variable technique to study the model with respect to both the first essential and second optional service. They consider service time to follow general distribution. Madan [9] proposed the concept of a single server queue with a second optional service and furnished its real time applications.

Choudary and Paul [4] discussed an $M^{[X]}/G/1$ queueing system with a second optional service channel under N -policy. Only when minimum N customers are present in queue, server starts serving present customers in the queue which is stated as N -policy. They found the queue size distribution at random epoch and departure epoch.

Maragathasundari and Srinivasan [11] discussed a non-Markovian queueing model with multi-stage of service. The numerical results of this model have been presented in graphical form, and they have also discussed the practical large-scale industrial applications.

Thangaraj and Vanitha [16] investigated an $M/G/1$ queue with two-stage heterogeneous service and random breakdowns. They have modelled the queueing system that could unexpectedly fail, causing the server to stop operating until the system is fixed. Gupta et al. [6] studied the steady-state behaviour of the $M^{[X]}/G/1$ with server breakdown. Customers will arrive to the system in varied sizes of batches, but will be served one by one, according to this study. The repair process does not begin immediately after a breakdown, and there is a time delay for repairs to start. Choudary and Tadj [5] analysed an $M/G/1$ queue with two service phases that was subject to server failure and delayed repair. An $M^{[X]}/G/1$ queue with second optional service and server breakdown was explored by Singh and Kaur [15]. Their study has numerous applications in everyday life, including tremendous utility for system designers and managements.

Santhi [14] developed a single server retrial queue with a second optional service and working vacation, assuming that there is no available waiting space for an arriving client. They can abandon the service area and join an orbit consisting of a pool of blocked clients. Rajadurai et al. [13] looked into an $M/G/1$ feedback retrial queue that was subjected to server breakdown, repair and multiple working vacations. To investigate the system's impact they presented a cost optimization analysis. This model is a generalised version of a number of current queueing models.

Working breakdown is very common in many manufacturing industries and production process. In queueing models, it is the most used parameter. Kalidass and Kasturi [7] have studied a queueing model with working breakdown. According to their research, if a server crashes at a certain point but doesn't completely shut down, the server continues to run at a slower speed. Kim and Lee [8] have analysed an $M/G/1$ queueing system with disaster and working breakdown. This study presents an extension of the queueing system and results may provide a better decision making for many practical system. Yang et al. [18] presented a two-server queue with multiple vacations and working breakdowns. They have used Matrix-geometric method to obtain the steady state probabilities and performance measures.

Rajadurai [12] recently investigated a retrial queueing system with several features. One of his assumptions is that disaster causes all clients to exit the system, and at the same time the main server fails. After that, the main server is sent to the repair station, and the repair process begins immediately. Finally, cost optimization analysis and some numerical results are presented. Ammar et al. [3] analysed the preemptive priority retrial queueing system with disaster under working breakdown. This model has some good applications in computer processing systems. The inclusion of a preemptive priority retrial queueing system in the presence of working breakdown services is a unique feature of this study. The optimization analysis of the N-policy $M/G/1$ queue with working breakdown was discussed by Yen et al. [19]. They have illustrated the effectiveness of the two-stage optimization model in this study, as well as some numerical results have been shown. Ayyappan et al. [1] studied a single server queue which serves two classes of customers under non-preemptive priority services, working breakdown, Bernoulli vacation, admission and balking.

Our model is potentially applicable to cellular networks, as we know that in cellular network each cell has a base station that controls the call admissions and the quality of service of the network. If we want to model the base station properly and adequately, we should consider the possibility of many users (customers) accessing the internet on their mobiles at the same time. Thus the services provided by the base station controller is required. As any other electronic component, the server is also exposed to risks due to external shocks, and therefore subject to breakdowns. At the same time, the services to mobile users are very important. Hence, the service providers cannot afford full interruptions in their services leading to backup servers being relied upon to provide services at reduced rates whenever the main sever is under repair.

2. Mathematical model description

The following assumptions for this model are:

- Customers enter the system in batches of varying sizes according to compound Poisson process with rate λ , and they are served one by one under 'first come-first served' basis.
- Let $\lambda c_i (i = 1, 2, 3, \dots)$ be the first order probability that a batch of i customers arrives at the system during a short interval of time $(t, t + dt)$, where $0 \leq c_i \leq 1$ and $\sum_{i=1}^{\infty} c_i = 1$ and $\lambda > 0$ is the mean arrival.
- The first essential service is required by all arriving customers, and its distribution function and density function are $B_1(x)$ and $b_1(x)$ respectively.
- Let $\mu_1(x)dx$ be the conditional probability of completion of the first essential service during $(x, x + dx]$, given that the elapsed service time is x . Then

$$\mu_1(x) = \frac{b_1(x)}{1 - B_1(x)},$$

and therefore $b_1(v) = \mu_1(v)e^{-\int_0^v \mu_1(x)dx}$.

- When a customer's first essential service is completely finished, the customer opts for the II-optional service with probability p and this optional service will immediately start. Otherwise, with probability $(1 - p)$ they may decide to exit the system, in which case a new customer (if any) is picked for their first essential service from the head of the queue.
- The second optional service time is also assumed to follow the general distribution, with distribution function density function as $B_2(x)$ and $b_2(x)$ respectively.
- Let $\mu_2(x)dx$ be the conditional probability of completion of the II-optional service during $(x, x + dx]$, given that the elapsed service time is x . Then

$$\mu_2(x) = \frac{b_2(x)}{1 - B_2(x)},$$

and therefore $b_2(v) = \mu_2(v)e^{-\int_0^v \mu_2(x)dx}$.

- When servicing a customer at first stage or second stage, the system may get breakdown and the breakdown times are supposed to occur under Poisson process with parameter α .
- After breakdown, instead of stopping the service completely, the server will complete the current service at a slower rates $\beta_1(x)$ and $\beta_2(x)$ for first essential service and optional service respectively.
- The working breakdown service (both essential and optional) time is also assumed to follow the general distribution, with distribution function density function are $Q_i(x)$ and $q_i(x)$, $i = 1, 2$ respectively. Then

$$\beta_i(x) = \frac{q_i(x)}{1 - Q_i(x)}$$

and therefore $q_i(v) = \beta_i(v)e^{-\int_0^v \beta_i(x)dx}$, $i = 1, 2$.

- On completion of current service at a slower rate, the server is sent to repair. The repair time follows general distribution with the rate of $\eta(x)$.

- Meanwhile after the repair, when the server returns to the system and when there are no customers throughout the system, the server remains in the idle state and waits for the customers to arrive.
- Various stochastic process taking part in the system are considered to be independent of each other.

The structure of the system representation in Fig. 1.

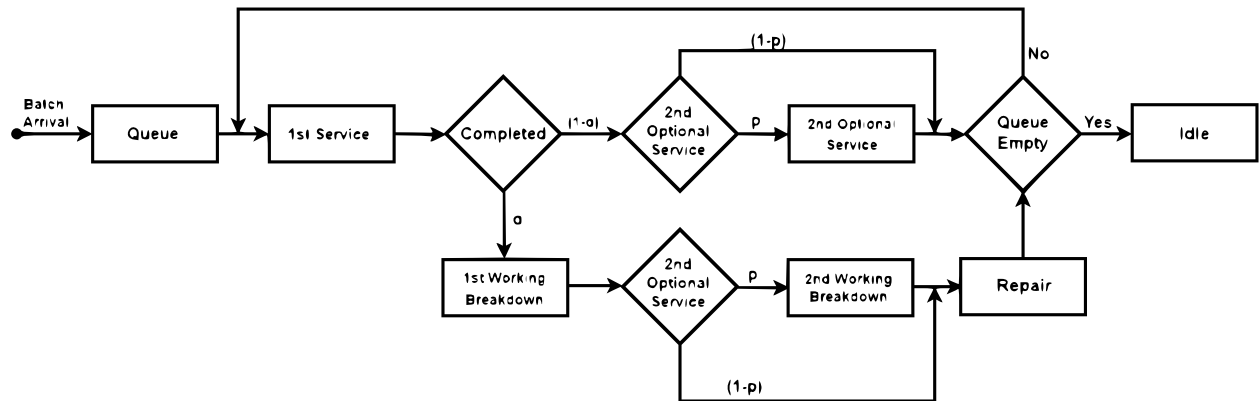

Figure 1. Diagrammatic representation of this model.

3. Notations and equations governing the system

Let $\sigma(t)$ denotes the server state: $N_s(t)$ denotes the number of customers in the service station, $N_q(t)$ denotes the number of customers in the queue.

Notations	Meaning
$P_n^{(1)}(x, t)$	$\sigma(t)$ = first essential service, $N_s(t) = 1$ and $N_q(t) = n(\geq 0)$, with elapsed service duration x at time t
$P_n^{(1)}(t) = \int_{x=0}^{\infty} P_n^{(1)}(x, t)dx$	$\sigma(t)$ = first essential service, $N_s(t) = 1$ and $N_q(t) = n(\geq 0)$, irrespective of the value of x
$P_n^{(2)}(x, t)$	$\sigma(t)$ = second optional service, $N_s(t) = 1$ and $N_q(t) = n(\geq 0)$, with elapsed service duration x at time t
$P_n^{(2)}(t) = \int_{x=0}^{\infty} P_n^{(2)}(x, t)dx$	$\sigma(t)$ = second optional service, $N_s(t) = 1$ and $N_q(t) = n(\geq 0)$, irrespective of the value of x
$Q_n^{(1)}(x, t)$	$\sigma(t)$ = first essential service at slower rate, $N_s(t) = 1$ and $N_q(t) = n(\geq 0)$, with elapsed service duration x at time t
$Q_n^{(1)}(t) = \int_{x=0}^{\infty} Q_n^{(1)}(x, t)dx$	$\sigma(t)$ = first essential service at slower rate, $N_s(t) = 1$ and $N_q(t) = n(\geq 0)$, irrespective of the value of x

$Q_n^{(2)}(x, t)$	$\sigma(t) =$ second optional service at slower rate, $N_s(t) = 1$ and $N_q(t) = n(\geq 0)$, with elapsed service duration x at time t
$Q_n^{(2)}(t) = \int_{x=0}^{\infty} Q_n^{(2)}(x, t)dx$	$\sigma(t) =$ second optional service at slower rate, $N_s(t) = 1$ and $N_q(t) = n(\geq 0)$, irrespective of the value of x
$R_n(x, t)$	$\sigma(t) =$ repair, $N_q(t) = n(\geq 0)$, with elapsed repair duration x at time t
$R_n(t) = \int_{x=0}^{\infty} R_n(x, t)dx$	$\sigma(t) =$ repair, $N_q(t) = n(\geq 0)$, irrespective of the value of x
$I(t)$	$\sigma(t) =$ Idle, $N_q(t) = 0$ at time t

The Kolmogorov forward equations to govern the model are the following:

$$\begin{aligned} & \frac{\partial}{\partial x} P_n^{(1)}(x, t) + \frac{\partial}{\partial t} P_n^{(1)}(x, t) \\ &= -(\lambda + \mu_1(x) + \alpha)P_n^{(1)}(x, t) + (1 - \delta_{0n})\lambda \sum_{i=1}^n c_i P_{n-i}^{(1)}(x, t), \quad n = 1, 2, \dots, \end{aligned} \tag{3.1}$$

$$\begin{aligned} & \frac{\partial}{\partial x} P_n^{(2)}(x, t) + \frac{\partial}{\partial t} P_n^{(2)}(x, t) \\ &= -(\lambda + \mu_2(x) + \alpha)P_n^{(2)}(x, t) + (1 - \delta_{0n})\lambda \sum_{i=1}^n c_i P_{n-i}^{(2)}(x, t), \quad n = 1, 2, \dots, \end{aligned} \tag{3.2}$$

$$\begin{aligned} & \frac{\partial}{\partial x} Q_n^{(1)}(x, t) + \frac{\partial}{\partial t} Q_n^{(1)}(x, t) \\ &= -(\lambda + \beta_1(x))Q_n^{(1)}(x, t) + (1 - \delta_{0n})\lambda \sum_{i=1}^n c_i Q_{n-i}^{(1)}(x, t), \quad n = 1, 2, \dots, \end{aligned} \tag{3.3}$$

$$\begin{aligned} & \frac{\partial}{\partial x} Q_n^{(2)}(x, t) + \frac{\partial}{\partial t} Q_n^{(2)}(x, t) \\ &= -(\lambda + \beta_2(x))Q_n^{(2)}(x, t) + (1 - \delta_{0n})\lambda \sum_{i=1}^n c_i Q_{n-i}^{(2)}(x, t), \quad n = 1, 2, \dots, \end{aligned} \tag{3.4}$$

$$\begin{aligned} & \frac{\partial}{\partial x} R_n(x, t) + \frac{\partial}{\partial t} R_n(x, t) \\ &= -(\lambda + \eta(x))R_n(x, t) + (1 - \delta_{0n})\lambda \sum_{i=1}^n c_i R_{n-i}(x, t), \quad n = 1, 2, \dots, \end{aligned} \tag{3.5}$$

$$\begin{aligned} \frac{d}{dt} I(t) &= -\lambda I(t) + (1 - p) \int_0^{\infty} P_0^{(1)}(x, t)\mu_1(x)dx + \int_0^{\infty} P_0^{(2)}(x, t)\mu_2(x)dx \\ &+ \int_0^{\infty} R_0(x, t)\eta(x)dx, \quad n = 1, 2, \dots. \end{aligned} \tag{3.6}$$

Equations (3.1) to (3.6) are to be solved subject to the following boundary conditions at $x = 0$.

$$\begin{aligned} P_n^{(1)}(0, t) &= \lambda c_{n+1} I(t) + (1 - p) \int_0^{\infty} P_{n+1}^{(1)}(x, t)\mu_1(x)dx + \int_0^{\infty} P_{n+1}^{(2)}(x, t)\mu_1(x)dx \\ &+ \int_0^{\infty} R_{n+1}\eta(x)(x, t)\gamma(x)dx, \end{aligned} \tag{3.7}$$

$$P_n^{(2)}(0, t) = p \int_0^\infty P_n^{(1)}(x, t) \mu_1(x) dx, \tag{3.8}$$

$$Q_n^{(1)}(0, t) = \alpha \int_0^\infty P_n^{(1)}(x, t) dx, \tag{3.9}$$

$$Q_n^{(2)}(0, t) = \alpha \int_0^\infty P_n^{(2)}(x, t) dx + p \int_0^\infty Q_n^{(1)}(x, t) \beta_1(x) dx, \tag{3.10}$$

$$R_n(0, t) = (1 - p) \int_0^\infty Q_n^{(1)}(x, t) \beta_1(x) dx + \int_0^\infty Q_n^{(2)}(x, t) \beta_2(x) dx. \tag{3.11}$$

The initial conditions are

$$I(0) = 1, \quad P^{(1)}(0) = P^{(2)}(0) = Q^{(1)}(0) = Q^{(2)}(0) = R(0) = 0. \tag{3.12}$$

4. Generating functions of the queue length: the time-dependent solution

We define the probability generating functions,

$$A_q(x, z, t) = \sum_{n=0}^\infty z^n A_n(x, t), \quad C(z) = \sum_{n=1}^\infty z^n c_n(t).$$

Here $A = P^{(1)}, P^{(2)}, Q^{(1)}, Q^{(2)}, R$ which are convergent inside the circle given by $|z| \leq 1$. By taking Laplace transform from equations from (3.1) to (3.11) and solving those equations we get,

$$\bar{P}_q^{(1)}(x, z, s) = \bar{P}_q^{(1)}(0, z, s) e^{-(s+\lambda(1-C(z)+\alpha)x - \int_0^x \mu_1(t) dt)}, \tag{4.1}$$

$$\bar{P}_q^{(2)}(x, z, s) = \bar{P}_q^{(2)}(0, z, s) e^{-(s+\lambda(1-C(z)+\alpha)x - \int_0^x \mu_2(t) dt)}, \tag{4.2}$$

$$\bar{Q}_q^{(1)}(x, z, s) = \bar{Q}_q^{(1)}(0, z, s) e^{-(s+\lambda(1-C(z))x - \int_0^x \beta_1(t) dt)}, \tag{4.3}$$

$$\bar{Q}_q^{(2)}(x, z, s) = \bar{Q}_q^{(2)}(0, z, s) e^{-(s+\lambda(1-C(z))x - \int_0^x \beta_2(t) dt)}, \tag{4.4}$$

$$\bar{R}_q(x, z, s) = \bar{R}_q(0, z, s) e^{-(s+\lambda(1-C(z))x - \int_0^x \eta(t) dt)}. \tag{4.5}$$

Again on integrating equations from (4.1) to (4.5) by parts with respect to x we get

$$\bar{P}_q^{(1)}(z, s) = \bar{P}_q^{(1)}(0, z, s) \left[\frac{1 - \bar{B}_1[f(z)]}{[f(z)]} \right], \tag{4.6}$$

$$\bar{P}_q^{(2)}(z, s) = \bar{P}_q^{(2)}(0, z, s) \left[\frac{1 - \bar{B}_2[f(z)]}{[f(z)]} \right], \tag{4.7}$$

$$\bar{Q}_q^{(1)}(z, s) = \bar{Q}_q^{(1)}(0, z, s) \left[\frac{1 - \bar{Q}_1[g(z)]}{[g(z)]} \right], \tag{4.8}$$

$$\bar{Q}_q^{(2)}(z, s) = \bar{Q}_q^{(2)}(0, z, s) \left[\frac{1 - \bar{Q}_2[g(z)]}{[g(z)]} \right], \tag{4.9}$$

$$\bar{R}_q(z, s) = \bar{R}_q(0, z, s) \left[\frac{1 - \bar{R}[g(z)]}{[g(z)]} \right], \tag{4.10}$$

where

$$f(z) = s + \lambda(1 - C(z)) + \alpha, \quad g(z) = s + \lambda(1 - C(z)).$$

Now multiplying both sides of equation (4.1) by $\mu_1(x)$ and equation (4.2) by $\mu_2(x)$ and equation (4.3) by $\beta_1(x)$, equation (4.4) by $\beta_2(x)$ and equation (4.5) by $\eta(x)$ and then integrating over x we obtain

$$\int_0^\infty \bar{P}_q^{(1)}(x, z, s) \mu_1(x) dx = \bar{P}_q^{(1)}(0, z, s) \bar{B}_1[f(z)], \tag{4.11}$$

$$\int_0^\infty \bar{P}_q^{(2)}(x, z, s) \mu_2(x) dx = \bar{P}_q^{(2)}(0, z, s) \bar{B}_2[f(z)], \quad (4.12)$$

$$\int_0^\infty \bar{Q}_q^{(1)}(x, z, s) \beta_1(x) dx = \bar{Q}_q^{(1)}(0, z, s) \bar{Q}_1[g(z)], \quad (4.13)$$

$$\int_0^\infty \bar{Q}_q^{(2)}(x, z, s) \beta_2(x) dx = \bar{Q}_q^{(2)}(0, z, s) \bar{Q}_2[g(z)], \quad (4.14)$$

$$\int_0^\infty \bar{R}_q(x, z, s) \eta(x) = \bar{R}_q(0, z, s) \bar{R}[g(z)]. \quad (4.15)$$

Using equations (4.11) and (3.8), we get

$$\bar{P}_q^{(2)}(0, z, s) = p[\bar{P}_q^{(1)}(0, z, s) \bar{B}_1[f(z)]].$$

Using equations (4.6) and (3.9), we get

$$\bar{Q}_q^{(2)}(0, z, s) = \alpha \bar{P}_q^{(1)}(0, z, s) \left[\frac{1 - \bar{B}_1[f(z)]}{[f(z)]} \right].$$

Performing similar operation in equations (3.10) and (3.11), we obtain

$$\begin{aligned} \bar{Q}_q^{(1)}(0, z, s) &= \alpha p \bar{P}_q^{(1)}(0, z, s) \left\{ \bar{B}_1[f(z)] \left[\frac{1 - \bar{B}_1[f(z)]}{[f(z)]} \right] + \bar{Q}_1[g(z)] \left[\frac{1 - \bar{B}_1[f(z)]}{[f(z)]} \right] \right\}, \\ \bar{R}_q(0, z, s) &= \bar{P}_q^{(1)}(0, z, s) \left\{ (1-p) \alpha \bar{Q}_1[g(z)] \left[\frac{1 - \bar{B}_1}{[f(z)]} \right] + \alpha p \bar{B}_1[f(z)] \bar{Q}_2[g(z)] \left[\frac{1 - \bar{B}_2[f(z)]}{[f(z)]} \right] \right. \\ &\quad \left. + \alpha p \bar{Q}_1[f(z)] \bar{Q}_2[g(z)] \left[\frac{1 - \bar{B}_2[f(z)]}{[f(z)]} \right] \right\}. \end{aligned}$$

Using equations (4.11), (4.12) and (4.15), to solve $\bar{P}_q^{(1)}(0, z, s)$

$$\bar{P}_q^{(1)}(0, z, s) = \frac{1 - [g(z)] \bar{I}(s)}{\left\{ \begin{aligned} &z - (1-p) \bar{B}_1[f(z)] + p \bar{B}_2[f(z)] \bar{B}_2[g(z)] + (1-p) \alpha \bar{Q}_1[g(z)] \\ &\left[\frac{1 - \bar{B}_1[f(z)]}{[f(z)]} \right] + \alpha p \bar{B}_1[f(z)] \bar{Q}_2[g(z)] \left[\frac{1 - \bar{B}_2[f(z)]}{[f(z)]} \right] \\ &+ \alpha p \bar{Q}_1[g(z)] \bar{Q}_2[g(z)] \bar{R}[g(z)] \left[\frac{1 - \bar{B}_1[f(z)]}{[f(z)]} \right] \end{aligned} \right\}}.$$

We see that equations (4.6) to (4.10) become to be as follows

$$\bar{P}_q^{(1)}(z, s) = \bar{P}_q^{(1)}(0, z, s) \left[\frac{1 - \bar{B}_1[f(z)]}{[f(z)]} \right], \quad (4.16)$$

$$\bar{P}_q^{(2)}(z, s) = p \bar{P}_q^{(1)}(0, z, s) \bar{B}_1[f(z)] \left[\frac{1 - \bar{B}_2[f(z)]}{[f(z)]} \right], \quad (4.17)$$

$$\bar{Q}_q^{(1)}(z, s) = \alpha \bar{P}_q^{(1)}(0, z, s) \left[\frac{1 - \bar{B}_1[f(z)]}{[f(z)]} \right] \left[\frac{1 - \bar{Q}_1[g(x)]}{[g(x)]} \right], \quad (4.18)$$

$$\begin{aligned} \bar{Q}_q^{(2)}(z, s) &= \alpha p \bar{P}_q^{(1)}(0, z, s) \bar{B}_1[f(z)] \left[\frac{1 - \bar{B}_2[f(z)]}{f(z)} \right] \left[\frac{1 - \bar{Q}_2[g(z)]}{[g(z)]} \right] \\ &+ \alpha p \bar{P}_q^{(1)}(z, 0) \bar{Q}_1[g(z)] \left[\frac{1 - \bar{B}_1[f(z)]}{[f(z)]} \right] \left[\frac{1 - \bar{Q}_2[g(z)]}{[g(z)]} \right], \end{aligned} \quad (4.19)$$

$$\begin{aligned}
 \bar{R}_q(z, s) = \bar{P}_q(0, z, s) & \left\{ \alpha(1-p)\bar{Q}_1[g(z)] \left[\frac{1 - \bar{B}_1[f(z)]}{[f(z)]} \right] \left[\frac{1 - \bar{R}[g(z)]}{[g(z)]} \right] \right. \\
 & + \alpha p \bar{P}_q(z, 0) \bar{B}_1[f(z)] \bar{Q}_2[g(z)] \left[\frac{1 - \bar{B}_2[f(z)]}{[f(z)]} \right] \left[\frac{1 - \bar{R}[g(z)]}{[g(z)]} \right] \\
 & \left. + \alpha p \bar{P}_q(z, 0) \bar{Q}_1[g(z)] \bar{Q}_2[g(z)] \left[\frac{1 - \bar{B}_1[f(z)]}{[f(z)]} \right] \right\} \left[\frac{1 - \bar{R}[g(z)]}{[g(z)]} \right].
 \end{aligned} \tag{4.20}$$

5. The steady state results

For the steady state probabilities, we suppress the argument t wherever it appears in the time-dependent analysis. This can be obtained by applying the well-known Tauberian property,

$$\lim_{s \rightarrow 0} s \bar{f}(s) = \lim_{t \rightarrow \infty} f(t).$$

Let $P(z)$ denote the probability generating function of the queue size irrespective of the state of the system. Then adding equations (4.16) to (4.20) we obtain

$$P(z) = \frac{\begin{bmatrix} I[1 - B_1(g(z))][f(z)] + pB_1(g(z))[1 - B_2(g(z))][f(z)] \\ + \alpha[1 - B_1(g(z))][1 - Q_1(f(z))] \\ + \alpha p[1 - B_2(g(z))][1 - Q_2(f(z))]B_1[g(z)] \\ + \alpha p Q_1[f(z)][1 - B_1(g(z))][1 - Q_2(f(z))] \\ + \alpha(1-p)[Q_1(f(z))][1 - B_1(g(z))][1 - R(f(z))] \\ + \alpha p[B_1(f(z))][Q_2(f(z))][1 - B_2(g(z))][1 - R(f(z))] \\ + \alpha p[Q_1(f(z))][Q_2(f(z))][1 - B_1(g(z))][1 - R(f(z))] \end{bmatrix}}{\begin{bmatrix} z(g(z)) - (1-p)B_1[g(z)]g(z) + pB_1[g(z)]B_2[g(z)]g(z) \\ + \alpha(1-p)Q_1[f(z)]R[f(z)][1 - B_1(g(z))] \\ + \alpha p B_1[g(z)]Q_2[f(z)]R[f(z)][1 - B_2(g(z))] \\ + \alpha p Q_1[f(z)]Q_2[f(z)]R[g(z)][1 - B_1(g(z))] \end{bmatrix}}. \tag{5.1}$$

We see that for $z = 1$, $P(z)$ is indeterminate of the form $0/0$. Therefore, we apply L'Hopital's rule and after simplification we obtain,

$$\begin{aligned}
 Q_1(0) = 1, \quad Q_2(0) = 1, \quad R(0) = 1, \quad -Q_1'(0) = E(Q_1), \quad -Q_2'(0) = E(Q_2), \\
 -R'(0) = E(R), \quad Q_1''(0) = E(Q^2), \quad Q_2''(0) = E(Q^2), \quad R''(0) = E(R^2).
 \end{aligned}$$

$$P(1) = \frac{\begin{bmatrix} -I\lambda[E(X)]\{1 - B_1(\alpha)\} + p[B_1(\alpha)][1 - B_2(\alpha)] + \alpha[1 - B_1(\alpha)] \\ [E(Q_1)] + \alpha[E(R)][1 - B_1(\alpha)] + \alpha p[B_1(\alpha)E(Q_2)][1 - B_2(\alpha)] \\ + B_1(\alpha) + B_1(\alpha)E(R)[1 - B_1(\alpha)] + E(Q_2)[1 - B_1(\alpha)] \end{bmatrix}}{\begin{bmatrix} \alpha - \lambda[E(X)]\{1 - B_1(\alpha)\} + P[B_1(\alpha)] + \alpha[E(Q_1)][1 - B_1(\alpha)] + E(R) \\ [1 - B_1(\alpha)] + \alpha p[B_1(\alpha)E(Q_2)][1 - B_2(\alpha)] \\ + B_1(\alpha)E(R)[1 - B_2(\alpha)] - B_1(\alpha)B_2'(\alpha) \end{bmatrix}}. \tag{5.2}$$

In order to determine I , we use the normalizing condition

$$P_q^{(1)}(1) + P_q^{(2)}(1) + Q_q^{(1)}(1) + Q_q^{(2)}(1) + R_q(1) + I = 1 \tag{5.3}$$

and we get

$$I = \frac{\left[\begin{array}{l} \alpha - \lambda[E(x)][1 - B_1(\alpha)] + \alpha[E(Q_1) + E(R)][1 - B_1(\alpha)] \\ + p[B_1(\alpha)] + \alpha p\{B_1(\alpha)E(Q_2)[1 - B_2(\alpha)] \\ + B_1(\alpha)E(R)[1 - B_2(\alpha)]\} - B_1(\alpha)B_2'(\alpha) \end{array} \right]}{\left[\begin{array}{l} \alpha - \lambda[E(x)]\{[1 - B_1(\alpha)] + \alpha[E(Q_1) + E(R)][1 - B_1(\alpha)] + p[B_1(\alpha)]\} \\ + \alpha p\{B_1(\alpha)E(Q_2)[1 - B_2(\alpha)] + B_1(\alpha)E(R)[1 - B_2(\alpha)]\} \\ - pB_1(\alpha)B_2(\alpha) + \alpha p[E(Q_2)[1 - B_1(\alpha)] - B_1(\alpha)B_2'(\alpha)] \end{array} \right]}. \quad (5.4)$$

Hence the utilization factor ρ of the system is given by

$$\rho = 1 - I, \quad (5.5)$$

where $\rho < 1$ is the stability condition under which the steady state exists. Equation (5.4) gives the probability that the server is idle.

6. Performance measures

Let L_q denote the mean number of customers in the queue under the steady state. Then

$$L_q = \lim_{z \rightarrow 1} \frac{d}{dt} P_q(z), \quad (6.1)$$

$$L_q = \lim_{z \rightarrow 1} \frac{d}{dt} \frac{N(z)}{D(z)}, \quad (6.2)$$

where

$$\begin{aligned} N(z) = & I[1 - B_1(g(z))][f(z)] + pB_1(g(z))[1 - B_2(g(z))][f(z)] + \alpha[1 - B_1(g(z))][1 - Q_1(f(z))] \\ & + \alpha p[1 - B_2(g(z))][1 - Q_2(f(z))]B_1[g(z)] + \alpha pQ_1[f(z)][1 - B_1(g(z))][1 - Q_2(f(z))] \\ & + \alpha(1 - p)[Q_1(f(z))][1 - B_1(g(z))][1 - R(f(z))] \\ & + \alpha p[B_1(f(z))][Q_2(f(z))][1 - B_2(g(z))][1 - R(f(z))] \\ & + \alpha p[Q_1(f(z))][Q_2(f(z))][1 - B_1(g(z))][1 - R(f(z))], \end{aligned}$$

$$\begin{aligned} D(z) = & z(g(z)) - (1 - p)B_1[g(z)]g(z) + pB_1[g(z)]B_2[g(z)]g(z) \\ & + \alpha(1 - p)Q_1[f(z)]R[f(z)][1 - B_1(g(z))] + \alpha pB_1[g(z)]Q_2[f(z)]R[f(z)][1 - B_2[g(z)]] \\ & + \alpha pQ_1[f(z)]Q_2[f(z)]R[g(z)][1 - B_1[g(z)]], \end{aligned}$$

therefore

$$L_q = \frac{[D'(1)N''(1) - N'(1)D''(1)]}{2[D'(1)]^2},$$

$$\begin{aligned} N'(1) = & -I\lambda[E(X)]\{[1 - B_1(\alpha)] + p[B_1(\alpha)][1 - B_2(\alpha)] + \alpha[E(Q_1)][1 - B_1(\alpha)] \\ & + \alpha[E(R)][1 - B_1(\alpha)] + \alpha p[B_1(\alpha) + B_1(\alpha)E(Q_2)[1 - B_2(\alpha)] \\ & + B_1(\alpha)E(R)[1 - B_2(\alpha)] + E(Q_2)[1 - B_1(\alpha)]\}, \end{aligned}$$

$$\begin{aligned}
N''(1) &= \lambda^2[E(X)]^2 \{ -B_1'(\alpha) + p[B_1'(\alpha) - B_1'(\alpha)B_2(\alpha) - B_1(\alpha)B_2'(\alpha)] \\
&\quad - \alpha[B_1'(\alpha)E(Q_1) + B_1'(\alpha)E(R) + E(Q_1^2)[1 - B_2(\alpha)] - E(R^2)[1 - B_1(\alpha)] \\
&\quad + E(Q_1)E(R)[1 - B_1(\alpha)]] - \alpha p[B_1(\alpha)B_2'(\alpha)E(Q_2) + B_1(\alpha)B_2(\alpha) \\
&\quad - B_1'(\alpha)E(Q_2)[1 - B_1(\alpha)] + B_1'(\alpha)E(Q_2) + E(Q_1)E(Q_2)[1 - B_1(\alpha)] \\
&\quad + E(Q_1)E(R)[1 - B_1(\alpha)] - B_1(\alpha)E(Q_2)E(R) + B_1(\alpha)E(R^2)[1 - B_2(\alpha)] \\
&\quad + E(Q_2)E(R) + E(Q_2^2)] \} + \lambda E(X^2) \{ [1 - B_1(\alpha)] - pB_1(\alpha)[1 - B_2(\alpha)] \\
&\quad - \alpha[E(Q_1)[1 - B_1(\alpha)] + E(R)[1 - B_1(\alpha)]] - \alpha p[E(R)B_1(\alpha)[1 - B_2(\alpha)] \\
&\quad + E(Q_2) - B_1(\alpha)E(R)[1 - B_2(\alpha)] \}, \\
D'(1) &= \alpha - \lambda[E(X)] \{ 1 - B_1(\alpha) + P[B_1(\alpha)] + \alpha[E(Q_1)[1 - B_1(\alpha)] + E(R)[1 - B_1(\alpha)]] \\
&\quad + \alpha p[B_1(\alpha)E(Q_2)[1 - B_2(\alpha)] + B_1(\alpha)E(R)[1 - B_2(\alpha)] - B_1(\alpha)B_2'(\alpha) \}, \\
D''(1) &= -2\lambda[E(X)] - \lambda^2[E(X)]^2 \{ (1 - p)[2B_1'(\alpha) + 2B_2'(\alpha)] \\
&\quad + p[\alpha B_1''(\alpha)B_2(\alpha) + \alpha B_1(\alpha)B_2''(\alpha) + 2B_1'(\alpha)B_2(\alpha) + 2B_1(\alpha)B_2'(\alpha) + 2\alpha B_1'(\alpha)B_2'(\alpha)] \\
&\quad + \alpha(1 - p)[E(Q_1^2)[1 - B_1(\alpha)] + E(R^2)[1 - B_1(\alpha)] + 2E(Q_1)B_1'(\alpha) \\
&\quad + 2E(R)B_1'(\alpha) + 2E(Q_1)E(R)[1 - B_1(\alpha)]] \\
&\quad + \alpha p[B_1'(\alpha)[1 - B_2(\alpha)] - B_1(\alpha)B_2''(\alpha) + B_1(\alpha)E(Q_2^2)[1 - B_2(\alpha)] \\
&\quad + B_1(\alpha)E(R^2)[1 - B_2(\alpha)] + 2B_1(\alpha)B_2'(\alpha)E(Q_2) + 2B_1(\alpha)B_2'(\alpha)E(R)] \\
&\quad - 2B_1'(\alpha)B_2'(\alpha) - 2B_1'(\alpha)E(Q_2)[1 - B_2(\alpha)] - 2B_1'(\alpha)E(R)[1 - B_2(\alpha)] \\
&\quad + 2B_1(\alpha)E(Q_2)E(R)[1 - B_2(\alpha)] \} - \lambda[E(X^2)] \{ z + (1 - p)[\alpha B_1'(\alpha) - B_1(\alpha)] \\
&\quad + p[\alpha B_1'(\alpha)B_2(\alpha) + \alpha B_1(\alpha)B_2'(\alpha) + B_1(\alpha)B_2(\alpha)] + \alpha(1 - p)[E(Q_1)[1 - B_1(\alpha)] \\
&\quad + E(R)[1 - B_1(\alpha)] + B_1(\alpha)] + \alpha p[B_1'(\alpha) - B_1'(\alpha)B_2(\alpha) - B_1(\alpha)B_2'(\alpha)] \\
&\quad - E(Q_2)B_1(\alpha)[1 - B_2(\alpha)] - E(R)B_1(\alpha)[1 - B_2(\alpha)] \}.
\end{aligned}$$

Let W_q denote the average waiting time of customers in the queue by Little's formula

$$W_q = \frac{L_q}{\lambda}.$$

Idle I has been found in (5.4) and substituting values of $N'(1)$, $N''(1)$, $D'(1)$ and $D''(1)$ in (6.2) we obtain L_q in closed form, further we define the average system size L by using Little's formula. Thus, we have

$$L = L_q + \rho,$$

where L_q has been found in equation (6.2) and ρ is obtained from equation (5.5) as

$$\rho = 1 - I.$$

7. Numerical results

This section presents numerical examples related to specific work. Various parameters specified for the system performance measures are illustrated using MATLAB. We consider service times and working breakdown times are exponentially distributed. Analytical results are validated with numerical results. The set of values which satisfy the stability condition, are taken for the table calculation.

For the Table 1, we choose the following arbitrary values

$$\lambda = 2, \quad \mu_1 = 3, \quad \mu_2 = 3, \quad \beta_1 = 2.6, \quad \beta_2 = 2.6, \quad \eta = 5, \quad p = 0.6.$$

It clearly shows that as long as the breakdown rate (α) increases, the idle time (I) decreases, the mean queue size (L_q) increases and the mean waiting time of the customers (W_q) also increases. Fig. 2 shows that the idle time I decreases for the increasing values of the breakdown rate (α).

Table 1. Effective of breakdown.

α	I	L_q	W_q
0.20	0.0055	0.2609	0.1304
0.25	0.0054	0.2868	0.1434
0.30	0.0048	0.3149	0.1575
0.35	0.0038	0.3461	0.1730
0.40	0.0024	0.3811	0.1905

Similarly, Fig. 3 and Fig. 4 show that both the average queue length (L_q) and the average waiting time of the customers in the queue (W_q) for the increasing values of the breakdown rate (α).

From the Table 2, we choose the following values

$$\lambda = 1.3, \quad \mu_2 = 0.3, \quad \beta_1 = 17, \quad \beta_2 = 0.36, \quad \eta = 0.95, \quad \alpha = 0.9, \quad p = 0.6.$$

For increasing service rate (μ_1), the idle time (I) increases, the mean queue size (L_q) decreases and the mean waiting time of the customers (W_q) also decreases.

Table 2. Effective of service rate.

μ_1	I	L_q	W_q
11	0.4916	9.6167	7.3975
12	0.4940	9.4750	7.2884
13	0.4960	9.3573	7.1979
14	0.4977	9.2580	7.1216
15	0.4992	9.1732	7.0563

Fig. 5 shows that the idle time (I) increases for the increasing values of the service rate (μ).

Similarly, Fig. 6 and Fig. 7 show that the average queue length (L_q) and the average waiting time in the queue (W_q) decrease for the increasing values of the service rate (μ).

8. Conclusion

We considered an $M^{[X]}/G/1$ queue with second optional service and working breakdown. Using the supplementary variable method, important performance measures are derived. Numerical illustrations are made to examine the validity of analytical results. Slower rate service instead of stopping service can reduce waiting time and queue length. It helps to avoid heavy loss in production and manufacturing industries.

REFERENCES

1. Ayyappan G., Thamizhselvi P., Somasundaram B., Udayageetha J. Analysis of an $M^{X_1}, M^{X_2}/G_1, G_2/1$ retrial queueing system with priority services, working breakdown, Bernoulli vacation, admission control and balking. *J. Stat. Manag. Syst.*, 2020. Vol. 24, No. 4. P. 685–702. DOI: [10.1080/09720529.2020.1744812](https://doi.org/10.1080/09720529.2020.1744812)
2. Al-Jararha J., Madan K.C. An $M/G/1$ queue with second optional service with general service time distribution. *Internat. J. Inform. Management Sci.*, 2003. Vol. 14, No. 2. P. 47–56.
3. Ammar S.I., Rajadurai P. Performance analysis of preemptive priority retrial queueing system with disaster under working breakdown services. *Symmetry*, 2019. Vol. 11, No. 3. P. 419–425. DOI: [10.3390/sym11030419](https://doi.org/10.3390/sym11030419)
4. Choudhury G., Paul M. A batch arrival queue with a second optional service channel under N -policy. *Stoch. Anal. Appl.*, 2006. Vol. 24, No. 1. P. 1–21. DOI: [10.1080/07362990500397277](https://doi.org/10.1080/07362990500397277)
5. Choudhury G., Tadj L. An $M/G/1$ queue with two phases of service subject to the server breakdown and delayed repair. *Appl. Math. Model.*, 2009. Vol. 33, No. 6. P. 2699–2709. DOI: [10.1016/j.apm.2008.08.006](https://doi.org/10.1016/j.apm.2008.08.006)
6. Gupta D., Solanki A., Agrawal K. M. Non-Markovian queueing system, $M^X/G/1$ with server breakdown and repair times. *Recent Res. Sci. Technol.*, 2011. Vol. 3, No. 7. P. 88–94.
7. Kalidass K., Kasturi R. A two phase service $M/G/1$ queue with a finite number of immediate Bernoulli feedbacks. *OPSEARCH*, 2014. Vol. 51, No. 2. P. 201–218. DOI: [10.1007/s12597-013-0136-3](https://doi.org/10.1007/s12597-013-0136-3)
8. Kim B.K., Lee D.H. The $M/G/1$ queue with disasters and working breakdowns. *Appl. Math. Model.*, 2014. Vol. 38, No. 5–6. P. 1788–1798. DOI: [10.1016/j.apm.2013.09.016](https://doi.org/10.1016/j.apm.2013.09.016)
9. Madan K. C. An $M/G/1$ queue with second optional service. *Queueing System*, 2000. Vol. 34. P. 37–46. DOI: [10.1023/A:1019144716929](https://doi.org/10.1023/A:1019144716929)
10. Maragathasundari S., Srinivasan S., Ranjitham A. Batch arrival queueing system with two stages of service. *Int. J. Math. Anal.*, 2014. Vol. 8, No. 6. P. 247–258. DOI: [10.12988/ijma.2014.411](https://doi.org/10.12988/ijma.2014.411)
11. Maragathasundari S., Srinivasan S. A non-Markovian multistage batch arrival queue with breakdown and reneging. *Math. Probl. Eng.*, 2014. Vol. 2014. Art. no. 519579. 16 p. DOI: [10.1155/2014/519579](https://doi.org/10.1155/2014/519579)
12. Rajadurai P. Sensitivity analysis of an $M/G/1$ retrial queueing system with disaster under working vacations and working breakdowns. *RAIRO-Oper. Res.*, 2018, Vol. 52, No. 1. P. 35–54. DOI: [10.1051/ro/2017091](https://doi.org/10.1051/ro/2017091)
13. Rajadurai P., Saravanarajan M. C., Chandrasekaran V. M. A study on $M/G/1$ feedback retrial queue with subject to server breakdown and repair under multiple working vacation policy. *Alexandria Eng. J.*, 2017. Vol. 57, No. 6. P. 947–962. DOI: [10.1016/j.aej.2017.01.002](https://doi.org/10.1016/j.aej.2017.01.002)
14. Santhi K. An $M/G/1$ retrial queue with second optional service and multiple working vacation. *Adv. Appl. Math. Sci.*, 2021. Vol. 20, No. 6. P. 1129–1146.
15. Singh C.J., Kaur S. $M^X/G/1$ queue with optional service and server breakdowns. In: *Performance Prediction and Analytics of Fuzzy, Reliability and Queueing Models. Asset Analytics. K. Deep, M. Jain, S. Salhi (eds.)*. Singapore: Springer, 2019. P. 177–189. DOI: [10.1007/978-981-13-0857-4_13](https://doi.org/10.1007/978-981-13-0857-4_13)
16. Thangaraj V., Vanitha S. $M/G/1$ queue with two-stage heterogeneous service compulsory server vacation and random breakdowns. *Int. J. Contemp. Math. Sci.*, 2010. Vol. 5, No. 7. P. 307–322.
17. Yang D.-Y., Chen Y.-H. Computation and optimization of a working breakdown queue with second optional service. *J. Ind. Production Eng.*, 2018. Vol. 35, No. 3. P. 181–188. DOI: [10.1080/21681015.2018.1439113](https://doi.org/10.1080/21681015.2018.1439113)
18. Yang D.-Y., Chen Y.-H., Wu C.-H. Modelling and optimisation of a two-server queue with multiple vacations and working breakdowns. *Int. J. Prod. Res.*, 2020. Vol. 58, No. 10. P. 3036–3048. DOI: [10.1080/00207543.2019.1624856](https://doi.org/10.1080/00207543.2019.1624856)
19. Yen T.-C., Wang K.-H., Chen J.-Y. Optimization analysis of the N policy $M/G/1$ queue with working breakdowns. *Symmetry*, 2020. Vol. 12, No. 4. P. 583–594. DOI: [10.3390/sym12040583](https://doi.org/10.3390/sym12040583)

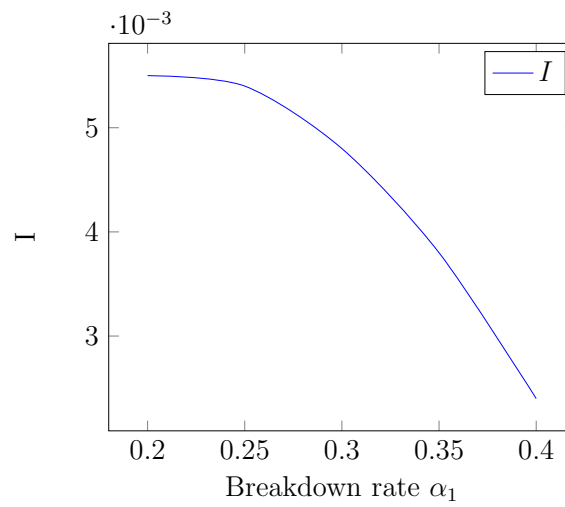

Figure 2. Breakdown rate vs Idle.

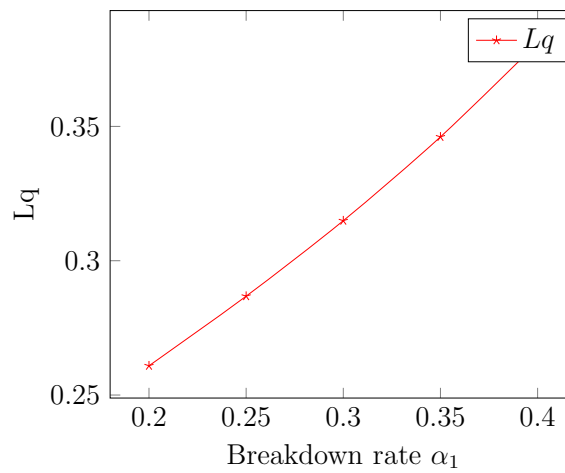

Figure 3. Breakdown rate vs Queue length.

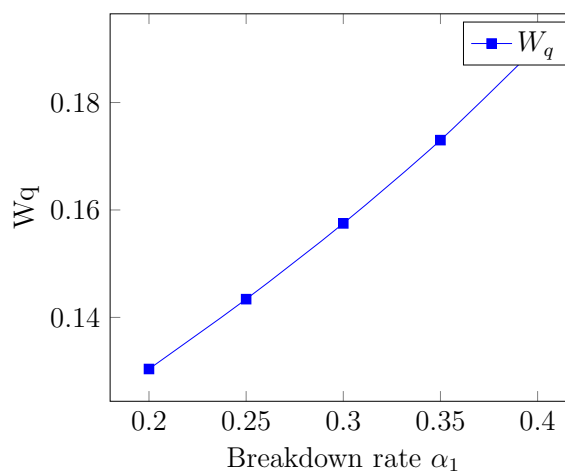

Figure 4. Breakdown rate vs Waiting time.

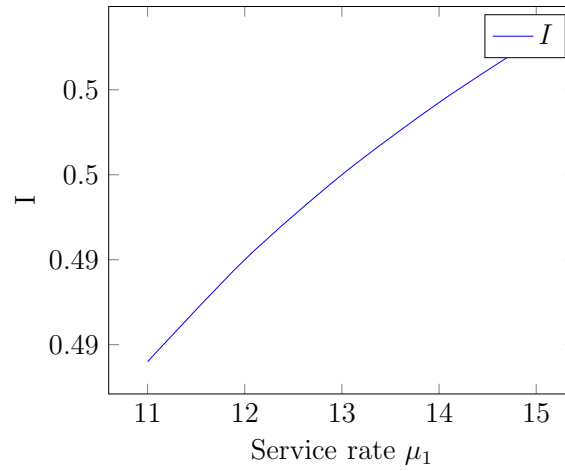

Figure 5. Service rate vs Idle.

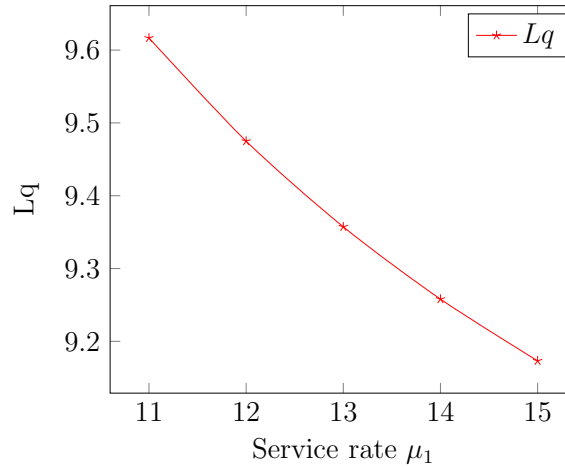

Figure 6. Service rate vs Queue length.

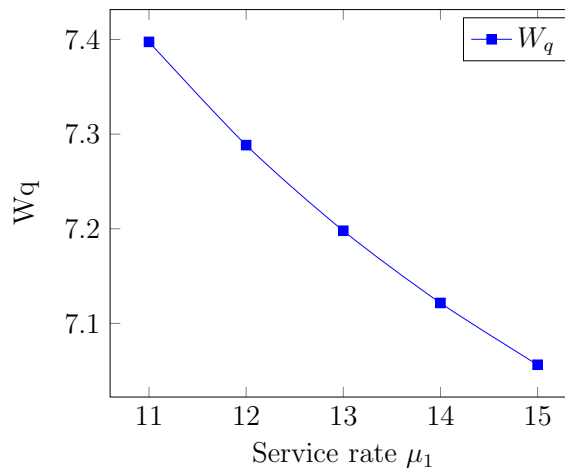

Figure 7. Service rate vs Waiting time.

ON NEW HYBRID ROOT-FINDING ALGORITHMS FOR SOLVING TRANSCENDENTAL EQUATIONS USING EXPONENTIAL AND HALLEY'S METHODS¹

Srinivasarao Thota

Department of Mathematics, Amrita School of Physical Sciences,
Amrita Vishwa Vidyapeetham, Amaravati, Andhra Pradesh–522503, India

srinithota@ymail.com

Tekle Gemechu

Department of Applied Mathematics, School of Applied Natural Sciences,
Adama Science and Technology University,
Post Box No. 1888, Adama, Ethiopia

tekgem@yahoo.com

Abayomi Ayotunde Ayoade

Department of Mathematics, University of Lagos,
Lagos State, Nigeria

ayoayoade@unilag.edu.ng

Abstract: The objective of this paper is to propose two new hybrid root finding algorithms for solving transcendental equations. The proposed algorithms are based on the well-known root finding methods namely the Halley's method, regula-falsi method and exponential method. We show using numerical examples that the proposed algorithms converge faster than other related methods. The first hybrid algorithm consists of regula-falsi method and exponential method (RF-EXP). In the second hybrid algorithm, we use regula-falsi method and Halley's method (RF-Halley). Several numerical examples are presented to illustrate the proposed algorithms, and comparison of these algorithms with other existing methods are presented to show the efficiency and accuracy. The implementation of the proposed algorithms is presented in Microsoft Excel (MS Excel) and the mathematical software tool Maple.

Keywords: Hybrid method, Halley's method, Regula-falsi method, Transcendental equations, Root-finding algorithms.

1. Introduction

The applications of nonlinear equations of the type $f(x) = 0$ arise in various branches of pure and applied sciences, such as computer science, chemical engineering, physics, etc. Getting the root of transcendental equations is of great importance. In recent time, several scientists and engineers have focused to solve nonlinear equations numerically as well as analytically. There are several iterative (hybrid) methods/algorithms available in the literature that are derived from various methods, see, for example [1–3, 10, 11, 15, 17–26]. In general, the roots of nonlinear or transcendental equations cannot be expressed in closed form or cannot be computed analytically.

¹Corresponding Authors email: t.srinivasarao@av.amrita.edu

Root finding algorithms allow us to compute approximations to roots, these approximations are expressed as either as small isolating intervals or as floating point numbers. The concept of creating hybrid methods, combining two or more classic approaches is not new and has a long history. One of the oldest hybrid root-finding method is Dekker's method, see for example [8], introduced in 1969. The main idea of this method is the combination of the classical methods i.e. bisection method and secant method. Using the idea of the Dekker's method, Richard P. Brent proposed a new hybrid root-finding method in 1973, see for example [5], which is based on the bisection method, the secant method and inverse quadratic interpolation. Since the Brent's method uses the idea of the Dekker's method, the method is also known as the Brent-Dekker method. In 1979, Ridders proposed a root-finding algorithm [13, 16] which is simpler than Brent's method and Dekker's method. This algorithm is based on the regula-falsi method and the exponential function. Badr et al. [1] proposed two hybrid algorithms. The first hybrid algorithm is based on the false-position method and the modified secant method (FP-MSe), and the second algorithm is based on the false-position method and the trigonometric secant method (FP-TMSe). Novak et al. [14] proposed a hybrid secant-bisection approach in 1995. Sabharwal [17] proposed a new hybrid method that combines two bracketing techniques (bisection-false position). Badr et al. [2], on the other hand, created a hybrid algorithm that combines two closed algorithms (trisection-false position). They tested their strategy on fifteen nonlinear and linear equations as a benchmark. They came to the conclusion that their algorithm outperformed Sabharwal's.

In this paper, we develop two new hybrid root finding algorithms for solving transcendental equations. These algorithms are created using the well-known root finding methods, namely the Halley's method, regula-falsi method and exponential method. Using numerical examples, we show that the proposed algorithms converge faster than the other related methods. The main idea of the first hybrid algorithm is based on the regula-falsi method and the exponential method (RF-EXP) and the second hybrid algorithm is based on the regula-falsi method and the Halley's method (RF-Halley). Several numerical examples are presented to illustrate the proposed algorithms. The comparisons are made to compare the results of calculations using the proposed algorithms with other existing methods to show efficiency and accuracy. Implementation of the proposed algorithms is presented in MS Excel and Maple.

The rest of the paper is organized as follows: in Section 2, we present two new hybrid root-finding algorithms with methodology and steps involving in the proposed algorithms; Section 3 discusses the analysis of convergence; Section 4 presents several numerical examples to illustrate and validate the proposed methods/algorithms; and finally Section 5 presents the implementation of the proposed algorithms in MS Excel and of the mathematical software tool Maple with examples of computations.

2. New hybrid algorithms

In this section, we present two blended root-finding algorithms. These algorithms have the advantages of open methods (fast) and bracketing method (convergent).

2.1. New hybrid Algorithm 1 (regula falsi-exponential algorithm)

In this section, we present a new hybrid algorithm using the regula-falsi method and the exponential method (RF-EXP). The regula-false method guarantees the existence of the root, while the exponential method gives faster convergence. The iterative formula used in exponential method is as follows, more details about this method can be found in [23]

$$x_{n+1} = x_n \exp \left(\frac{-f(x_n)}{x_n f'(x_n)} \right), \quad n = 0, 1, 2, \dots \quad (2.1)$$

In regula-falsi method [4, 7, 9, 12], we take two initial guesses, say a and b , such that $f(a)f(b) < 0$. The approximate root is calculated by finding the point of intersection of the straight line joining the points $(a, f(a))$ and $(b, f(b))$ with the x -axis. Hence the approximate root can be calculated using the formula

$$x_r = a - \frac{f(a)(b-a)}{f(b)-f(a)}. \quad (2.2)$$

Now, we have to choose the appropriate interval to compute the second iteration. We have the following possible cases:

1. If $f(a)f(x_r) < 0$, then the root exists in $[a, x_r]$, and we set $b = x_r$ to find the second iteration using formula (2.2).
2. If $f(a)f(x_r) > 0$, then the root exists in $[x_r, b]$, and we set $a = x_r$ to find the second approximate root using (2.2).
3. If $f(x_r) = 0$, then the required root is x_r and we terminate the process.

Algorithm 1. In this algorithm, we have:

the input: the function $f(x)$, the interval $[a, b]$ where the exact root lies in, the absolute error eps , the number of iterations n ; the output: the approximate root x , the function value $f(x)$. The steps of the algorithm are as follows:

1. $i = 0$
2. **while** $i! = n$ **do**
3. $i = i + 1$;
4. $x_{rf} = a - \frac{f(a)(b-a)}{f(b)-f(a)}$
5. $x_i = x_{rf} \exp\left(\frac{-f(x_{rf})}{x_{rf}f'(x_{rf})}\right)$
6. **if** $|a - x_i| \leq eps$ **then**
7. **return** $x_i, f(x_i)$ **break**;
8. **else if** $f(x_i) * f(a) < 0$ **then** $b = x_i$
9. **else** $a = x_i$
10. **end (if)**
11. **end (while)**

In section 4, we present several examples to illustrate this algorithm and to show its efficiency.

2.2. New hybrid Algorithm 2 (regula falsi-Halley algorithm)

In this section, we present another new hybrid algorithm using regula-falsi method and Halley's method (RF-Halley). Similar to the previous new algorithm, the regula-falsi method guarantees the existence of the root and the Halley's method gives the fast convergence. The Halley's method is invented by Edmond Halley. In this method, we need one initial approximation as in the Newton's method with a continuous second derivative, and this method produces a sequence of approximations to the root. We compute the sequence of iterations using the Halley's method formula [6, 7] as

$$x_{n+1} = x_n - \frac{2f(x_n)f'(x_n)}{2[f'(x_n)]^2 - f(x_n)f''(x_n)}$$

with an initial approximation x_0 .

Algorithm 2. In this algorithm, we have: the input: the function $f(x)$, the interval $[a, b]$ where the exact root lies in, the absolute error eps , the number of iterations n ; the output: the approximate root x , the function value $f(x)$. The steps of the algorithm are as follows:

1. $i = 0$
2. **while** $i! = n$ **do**
3. $i = i + 1$;
4. $x_{rf} = a - \frac{f(a)(b-a)}{f(b)-f(a)}$
5. $x_i = x_{rf} - \frac{2f(x_{rf})f'(x_{rf})}{2[f'(x_{rf})]^2 - f(x_{rf})f''(x_{rf})}$
6. **if** $|a - x_i| \leq eps$ **then**
7. **return** $x_i, f(x_i)$ **break**;
8. **else if** $f(x_i) * f(a) < 0$ **then** $b = x_i$
9. **else** $a = x_i$
10. **end (if)**
11. **end (while)**

2.3. Flow-diagrams

In this section, we present the flow diagrams of the proposed algorithms. In Fig. 1, we present the flow diagram of Algorithm 1 and the Fig. 2 presents the flow diagram of Algorithm 2.

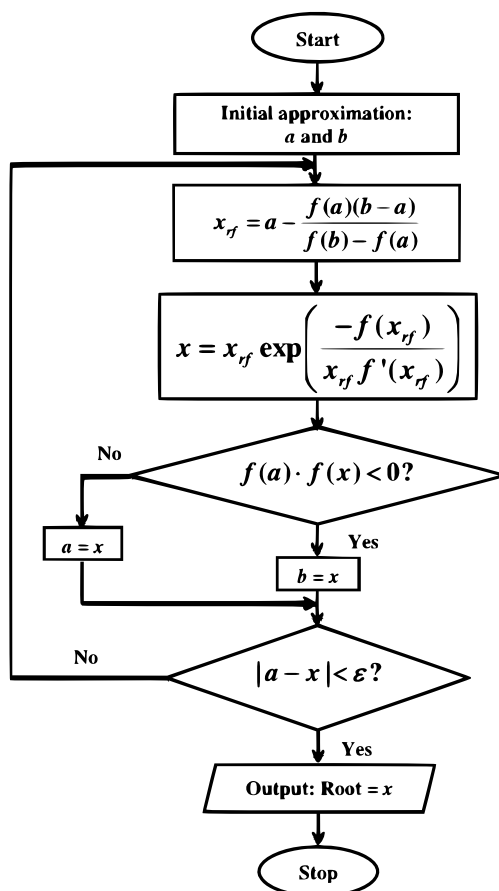

Figure 1. Flow-diagram of Algorithm 1.

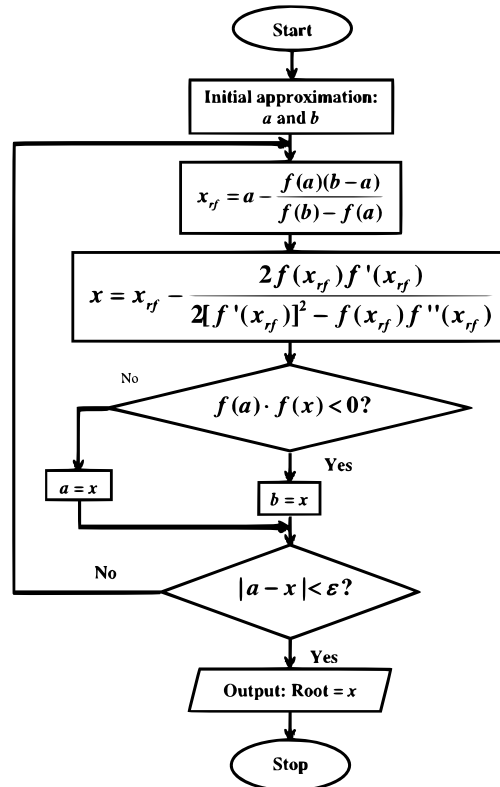

Figure 2. Flow-diagram of Algorithm 2.

In Section 4, we present several examples to illustrate this algorithm and to show the efficiency of the algorithm.

3. Convergence analysis

The main idea of the proposed algorithms is the combination of the open methods and the closed methods. Hence, the proposed algorithms converge to the approximate root faster. On the other hand, when the open methods (exponential method or Halley's method) fail, the closed method (false position) continues to get the next approximations, so the proposed algorithms RF-EXP and RF-Halley are convergent faster with a guaranteed root.

4. Numerical examples

In this section, we present several numerical examples to illustrate the proposed algorithms, and comparisons are made to confirm that the proposed algorithms give a solution faster than some existing methods. The following Example 1 and Example 2 illustrate the proposed algorithms.

Example 1. Consider the nonlinear equation

$$e^{-x} - x = 0, \quad (4.1)$$

with the initial approximations $a = 0$ and $b = 1$. Following the proposed Algorithm 1, we have

$$\begin{aligned} x_{rf} &= 0.612699837, \\ x_1 &= 0.568452077, \quad f(x_1) = -0.00205057. \end{aligned}$$

Now, we verify the possible three conditions given in regula-falsi method, and we get the required interval where the exact root lies in, as $[0, 0.568452077]$. Repeat the process for higher iterations, and we have

$$\begin{aligned}x_{rf} &= 0.567288811, \\x_2 &= 0.567143305, \quad f(x_2) = -2.32442 \times 10^{-8}, \\x_{rf} &= 0.567143292, \\x_3 &= 0.56714329, \quad f(x_3) \approx 0.\end{aligned}$$

The nonlinear equation in (4.1) is solved using well known methods to compare the results (see Table 1) with the proposed Algorithm 1 up to 8 correct decimal places.

In Table 1, BM, RFM, NRM, Halley, Steffensen and PA indicate the bisection method, regula-falsi method, Newton-Raphson method, Halley's method, Steffensen's method and the proposed algorithm (PA) respectively.

Table 1. Numerical results and comparisons.

BM	RFM	NRM	Halley	Steffensen	PA
24	8	4	3	4	3

Example 2. We apply the Algorithm 2 to the function

$$f(x) = e^x - 3x - 2$$

with initial approximations $a = 2$ and $b = 3$. Following the proposed Algorithm 2 similar to Example 1, we have

$$\begin{aligned}x_{rf} &= 2.063006766, \\x_1 &= 2.12530056, \quad f(x_1) = -0.000487257.\end{aligned}$$

Now, we verify the possible three conditions given in regula-falsi method, and we get the required interval where the exact root lies in, as $[2.12530056, 3]$. Repeat the process for higher iterations. So we have

$$\begin{aligned}x_{rf} &= 2.125347467, \\x_2 &= 2.1253911988111, \quad f(x_2) = -1.56319 \times 10^{-13}, \\x_{rf} &= 2.12539119881112, \\x_3 &= 2.12539119881113, \quad f(x_3) \approx 0.\end{aligned}$$

Example 3. In this example, we present a comparison between various existing methods and the proposed algorithms to show the efficiency and simplicity of the proposed algorithms in computation of a root. Consider ten standard nonlinear equations given in Table 2.

Using various numerical existing methods, we compute the roots of the ten equations given in Table 2 to ten decimal places. In Table 3, we present the number of iterations required to obtain

Table 2. Ten nonlinear equations for comparison with various methods.

S.No.	Equation	Initial approximations	Exact root
Eq.1	$e^x - 3x - 2 = 0$	$a = 2, b = 3$	2.1253911988
Eq.2	$x - \cos x = 0$	$a = 0, b = 1$	0.7390851332
Eq.3	$e^{-x} - x = 0$	$a = 0, b = 1$	0.5671432904
Eq.4	$x^2 - 5$	$a = 2, b = 7$	2.2360679775
Eq.5	$x^2 + e^{x/2} - 5$	$a = 1, b = 2$	1.6490132683
Eq.6	$\sin x - x^2$	$a = 0.5, b = 1$	0.8767262154
Eq.7	$x^2 - e^x - 3x + 2$	$a = 0, b = 1$	0.2575302854
Eq.8	$x^3 - 10$	$a = 2, b = 3$	2.154434690
Eq.9	$xe^{-x} - 0.1$	$a = 0, b = 1$	0.1118325592
Eq.10	$\cos x - x$	$a = 0, b = 1$	0.7390851332

Table 3. Numerical results and comparisons.

S.No.	BM	RFM	NRM	Halley	Steffensen	EXP	TRIG	Alg.1	Alg.2
Eq.1	29	25	6	4	5	4	4	3	3
Eq.2	31	9	5	3	5	3	3	3	2
Eq.3	32	11	4	3	4	5	4	3	2
Eq.4	32	28	4	3	6	3	5	3	2
Eq.5	30	10	5	4	5	5	6	4	2
Eq.6	30	12	5	4	4	4	5	4	2
Eq.7	32	7	4	4	4	3	4	3	1
Eq.8	29	17	5	3	21	3	4	3	1
Eq.9	34	12	5	8	6	5	5	2	2
Eq.10	31	9	4	3	5	4	4	3	1

the required root; and the terms BM, RFM, NRF, Halley, Steffensen, EXP, TRIG, Alg. 1 and Alg. 2 indicate bisection method, regula-falsi method, Newton-Raphson method, Helley's method, Steffensen's method, exponential method [23], trigonometric method [18], proposed Algorithm 1 and proposed Algorithm 2 respectively.

From Table 3, one can observe that the proposed algorithms required less number of iterations by comparing with other existing methods.

5. Implementation

In this section, we discuss the implementation of the proposed algorithms in MS Excel and Maple. We can also implement these algorithms in other mathematical software tools such as MATLAB, SCILab, Mathematica, Singular etc.

5.1. Implementation in MS Excel

The proposed algorithms can be computed in Excel as follows. The number of iterations r , initial guesses x_l , x_u and $f(x_l)$, $f(x_u)$, x_{r1} , $f(x_{r1})$, $f'(x_{r1})$, $f''(x_{r1})$, x_r , $f(x_r)$ are entered in the MS Excel cells, for example, at A5, B5, C5, D5, E5, F5, G5, H5, I5, J5, K5 respectively. Enter the respective values in 6th row, i.e., $r = 1$, x_l , x_u and “=f(B6)”, “=f(C6)”, “=(B6*E6-C6*D6)/(E6-D6)”, “=f(F6)”, “=f'(F6)”, “=f''(F6)”. Now the first estimated root using Algorithm 1 is obtained by entering the formula in J6 as “=F6*EXP((-G6)/(F6*H6))”; and the first estimated root using Algorithm 2 is obtained by entering the formula in J6 as “=F6-((2*G6*H6)/((2*(H6)^2)-(G6*I6)))”, where F6 in both algorithms is obtained using “=(B6*E6-C6*D6)/(E6-D6)”. In the last column K6, we check the function value at the estimated root $f(x_r)$ as “=f(J6)”. For second iteration, we need to check the three conditions in the method and the entries of 18th row of the excel sheet are as follows. The iteration r is entered with “=A6+1” in A18. The important steps in this algorithm (selection of appropriate sub-interval for next iterations) are entered in B7 and C7 with commands “=IF(D6*K6<0,B6,J6)” and “=IF(E6*K6<0, C6,J6)” respectively. The last columns, D6–K6 are drag down for next iteration value. Finally, drag down the entire 7th row until the required number of iterations.

Sample computations using MS Excel

Consider the function $f(x) = e^{-x} - x$ with initial approximations $x_l = 0$ and $x_u = 1$ and we have $f'(x) = -e^{-x} - 1$, $f''(x) = e^{-x}$. Now following the procedure given in Section 5.1, we have computations using Algorithm 1 as in Table 4 and computations using Algorithm 2 as in Table 5.

Table 4. Proposed Algorithm 1 in Excel.

r	x_l	x_u	$f(x_l)$	$f(x_u)$	x_{r1}	$f(x_{r1})$	$f'(x_{r1})$	x_r	$f(x_{r1})$
1	0	1	1	-0.6321	0.6127	-0.07081	-1.5419	0.5671	-0.0021
2	0	0.5685	1	-0.0021	0.5673	-2.99E-04	-1.5671	0.5671	-2.3E-08
3	0	0.5671	1	-2.3E-08	0.5671	-2.59E-09	-1.5671	0.5671	0

Table 5. Proposed Algorithm 2 in Excel.

r	x_l	x_u	$f(x_l)$	$f(x_u)$	x_{r1}	$f(x_{r1})$	$f'(x_{r1})$	$f''(x_{r1})$	x_r	$f(x_{r1})$
1	0	1	1	-0.6321	0.6127	-0.07081	-1.5419	0.54189	0.5671	4.1E-06
2	0.5671	1	4.1E-06	-0.6321	0.5671	-2.99E-07	-1.5671	0.5671	0.5671	0

5.2. Maple implementation

In this section, we present the maple implementation of the proposed algorithms with sample computations as follows.

Algorithm 1 in Maple

```
RFEXP := proc (a, b, Eq, eps, n)
```

```

local a1, b1, f, c, i, c1;
i := 0;
a1 := evalf(a);
b1 := evalf(b);
f := unapply(lhs(Eq), x);
if f(a1) = 0 then
return a1
else if f(b1) = 0 then
return b1
else if 0 < f(a1)*f(b1) then
error "Should be f(a)*f(b)<0"
end if;
end if;
end if;
do
c1 := (a1*f(b1)-b1*f(a1))/(f(b1)-f(a1));
c := c1*exp(-f(c1)/(c1*(D(f))(c1)));
i := i+1;
if f(c) = 0 or |c-a1| < eps or i = n then
return c
else if f(a1)*f(c) < 0 then
b1 := c
else a1 := c
end if;
end if;
printf("Iteration %g : x = %g \n", i, c)
end do
end proc

```

Algorithm 2 in Maple

```

RFHalley := proc (a, b, Eq, eps, n)
local a1, b1, f, c, i, c1;
i := 0;
a1 := evalf(a);
b1 := evalf(b);
f := unapply(lhs(Eq), x);
if f(a1) = 0 then
return a1
else if f(b1) = 0 then
return b1
else if 0 < f(a1)*f(b1) then
error "Should be f(a)*f(b)<0"
end if;
end if;
end if;
do
c1 := (a1*f(b1)-b1*f(a1))/(f(b1)-f(a1));
c := c1-(2*f(c1)*f'(c1)/(2*f'(c1)^2-f(c1)*(f''(c1))))

```

```

i := i+1;
if f(c) = 0 or |c-a1| < eps or i = n then
return c
else if f(a1)*f(c) < 0 then
b1 := c
else a1 := c
end if;
end if;
printf("Iteration %g : x = %g \n", i, c)
end do
end proc

```

Sample computations using Maple

Consider a function $f(x) = x - \cos x$ with initial conditions $a = 0$ and $b = 1$ with $\epsilon = 10^{-10}$. Now applying the maple implementation, we have the following computations using Algorithm 1 and Algorithm 2.

```
> RFEXP(0, 1, x-cos(x) = 0, 10^(-10), 10);
```

Iteration 1 : x = 0.742009

Iteration 2 : x = 0.739086

Iteration 3 : x = 0.739085

0.7390851332

```
> RFHalley(0, 1, x-cos(x) = 0, 10^(-10), 10);
```

Iteration 1 : x = 0.739066

0.7390851332

6. Conclusion

In this paper, we propose two hybrid root finding algorithms to solve the given transcendental equations. The algorithms are based on the Halley's method, regula-falsi method and exponential method. Several numerical examples are presented to illustrate the proposed algorithms. The first hybrid algorithm consists of regula-falsi method and exponential method, and the second hybrid algorithm consists of regula-falsi method and Halley's method. MS Excel and Maple implementation of the proposed algorithms are presented with sample computations. One can implement these algorithms in other software tools such as Matlab, SciLab, Mathematica etc. The proposed algorithms perform faster than some existing methods.

Acknowledgments

The authors are thankful to the reviewers and editor for providing valuable inputs to improve the quality and present format of the manuscript.

REFERENCES

1. Badr E., Attiya H., El Ghamry A. Novel hybrid algorithms for root determining using advantages of open methods and bracketing methods. *Alexandria Eng. J.*, 2022. Vol. 61, No. 12. P. 11579–11588. DOI: [10.1016/j.aej.2022.05.007](https://doi.org/10.1016/j.aej.2022.05.007)

2. Badr E., Almotairi S., El Ghamry A. A Comparative study among new hybrid root finding algorithms and traditional methods. *Mathematics*, 2021. Vol. 9, No. 11. Art. no. 1306. DOI: [10.3390/math9111306](https://doi.org/10.3390/math9111306)
3. Badr E.M., ElGendy H.S. A hybrid water cycle-particle swarm optimization for solving the fuzzy underground water confined steady flow. *Indones. J. Electr. Eng. Comput. Sci.*, 2020. Vol. 19, No. 1. P. 492–504. DOI: [10.11591/ijeecs.v19.i1.pp492-504](https://doi.org/10.11591/ijeecs.v19.i1.pp492-504)
4. Baskar S., Ganesh S.S. *Introduction to Numerical Analysis*. Powai, Mumbai, India: Depart. Math., Indian Inst. Tech. Bombay, 2016. 230 p.
5. Brent R. P. *Algorithms for Minimization without Derivatives*. Englewood Cliffs, NJ: Prentice-Hall, 1973. 195 p.
6. Burden R. L., J. Douglas Faires. *Numerical Analysis*, 3rd ed. Baston, USA: PWS Publishing, 1985. 676 p.
7. Chapra S. C., Canale R. P. *Numerical Methods for Engineers*, 7th ed. Boston, MA, USA: McGraw-Hill, 2015. 970 p.
8. Dekker T. J. Finding a zero by means of successive linear interpolation. In: *Constructive Aspects of the Fundamental Theorem of Algebra*, B. Dejon, P. Henrici (eds.). London: Wiley-Interscience, 1969. P. 37–48.
9. Fink K.D., Mathews J.H. *Numerical Methods Using Matlab*, 4th ed. Upper Saddle River, NJ, USA: Prentice-Hall Inc., 2004. 696 p.
10. Gemechu T., Thota S. On new root finding algorithms for solving nonlinear transcendental equations. *Int. J. Chem., Math. Phys.*, 2020. Vol. 4, No. 2. P. 18–24. DOI: [10.22161/ijcmp.4.2.1](https://doi.org/10.22161/ijcmp.4.2.1)
11. Hasan A. Numerical study of some iterative methods for solving nonlinear equations. *Int. J. Eng. Sci. Invent.*, 2016. Vol. 5, No. 2. P. 1–10.
12. Hoffman J. D. *Numerical Methods for Engineers and Scientists*, 2nd ed. NY, Basel: Marcel Dekker Inc., 2001. 823 p.
13. Kiusalaas J. *Numerical Methods in Engineering with Python*, 2nd ed. Cambridge: Cambridge University Press, 2010. 432 p.
14. Novak E., Ritter K., Woźniakowski H. Average-case optimality of a hybrid secant-bisection method. *Math. Comput.*, 1995. Vol. 64, No. 212. P. 1517–1539. DOI: [10.2307/2153369](https://doi.org/10.2307/2153369)
15. Parveen T., Singh S., Thota S., Srivastav V. K. A new hybrid root-finding algorithm for transcendental equations using bisection, regula-falsi and Newton-Raphson methods. In: *National Conf. Sustainable & Recent Innovation in Science and Engineering (SUNRISE-19)*, 2019.
16. Ridders C. A new algorithm for computing a single root of a real continuous function. *IEEE Trans. Circuits Syst.*, 1979. Vol. 26, No. 11. P. 979–980. DOI: [10.1109/TCS.1979.1084580](https://doi.org/10.1109/TCS.1979.1084580)
17. Sabharwal C. L. Blended root finding algorithm outperforms bisection and regula falsi algorithms. *Mathematics*, 2019. Vol. 7, No. 11. Art. no. 1118. DOI: [10.3390/math7111118](https://doi.org/10.3390/math7111118)
18. Srivastav V.K., Thota S., Kumar M. A new trigonometrical algorithm for computing real root of non-linear transcendental equations. *Int. J. Appl. Comput. Math.*, 2019. Vol. 5. Art. no. 44. DOI: [10.1007/s40819-019-0600-8](https://doi.org/10.1007/s40819-019-0600-8)
19. Thota S., Srivastav V. K. An algorithm to compute real root of transcendental equations using hyperbolic tangent function. *Int. J. Open Problems Compt. Math.*, 2021. Vol. 14, No. 2. P. 1–14.
20. Thota S. A numerical algorithm to find a root of non-linear equations using householder's method. *Int. J. Adv. Appl. Sci.*, 2021. Vol. 10, No. 2. P. 141–148. DOI: [10.11591/ijaas.v10.i2.pp141-148](https://doi.org/10.11591/ijaas.v10.i2.pp141-148)
21. Thota S., Gemechu T., Shanmugasundaram P. New algorithms for computing a root of non-linear equations using exponential series. *Palestine J. Math.*, 2021. Vol. 10, No. 1. P. 128–134.
22. Thota S., Gemechu T. A new algorithm for computing a root of transcendental equations using series expansion. *Southeast Asian J. Sci.*, 2019. Vol. 7, No. 2. P. 106–114.
23. Thota S. A new root-finding algorithm using exponential series. *Ural Math. J.*, 2019. Vol. 5, No. 1. P. 83–90. DOI: [10.15826/umj.2019.1.008](https://doi.org/10.15826/umj.2019.1.008)
24. Thota S., Srivastav V.K. Quadratically convergent algorithm for computing real root of non-linear transcendental equations. *BMC Res. Notes*, 2018. Vol. 11. Art. no. 909. DOI: [10.1186/s13104-018-4008-z](https://doi.org/10.1186/s13104-018-4008-z)
25. Thota S., Srivastav V. K. Interpolation based hybrid algorithm for computing real root of non-linear transcendental functions. *Int. J. Math. Comp. Res.*, 2014. Vol. 2, No. 11. P. 729–735.
26. Thota S. A new hybrid halley-false position type root finding algorithm to solve transcendental equations. In: *Istanbul International Modern Scientific Research Congress-III, 06–08 May 2022*. Istanbul, Turkey: Istanbul Gedik University, 2022. P. 1–2.

ON ONE ZALCMAN PROBLEM FOR THE MEAN VALUE OPERATOR

Natalia P. Volchkova

Donetsk National Technical University,
58 Artioma str., Donetsk, 283000, Russian Federation
volchkova.n.p@gmail.com

Vitaliy V. Volchkov

Donetsk State University,
24 Universitetskaya str., Donetsk, 283001, Russian Federation
volna936@gmail.com

Abstract: Let $\mathcal{D}'(\mathbb{R}^n)$ and $\mathcal{E}'(\mathbb{R}^n)$ be the spaces of distributions and compactly supported distributions on \mathbb{R}^n , $n \geq 2$, respectively, let $\mathcal{E}'_4(\mathbb{R}^n)$ be the space of all radial (invariant under rotations of the space \mathbb{R}^n) distributions in $\mathcal{E}'(\mathbb{R}^n)$, let \tilde{T} be the spherical transform (Fourier–Bessel transform) of a distribution $T \in \mathcal{E}'_4(\mathbb{R}^n)$, and let $\mathcal{Z}_+(\tilde{T})$ be the set of all zeros of an even entire function \tilde{T} lying in the half-plane $\operatorname{Re} z \geq 0$ and not belonging to the negative part of the imaginary axis. Let σ_r be the surface delta function concentrated on the sphere $S_r = \{x \in \mathbb{R}^n : |x| = r\}$. The problem of L. Zalcman on reconstructing a distribution $f \in \mathcal{D}'(\mathbb{R}^n)$ from known convolutions $f * \sigma_{r_1}$ and $f * \sigma_{r_2}$ is studied. This problem is correctly posed only under the condition $r_1/r_2 \notin M_n$, where M_n is the set of all possible ratios of positive zeros of the Bessel function $J_{n/2-1}$. The paper shows that if $r_1/r_2 \notin M_n$, then an arbitrary distribution $f \in \mathcal{D}'(\mathbb{R}^n)$ can be expanded into an unconditionally convergent series

$$f = \sum_{\lambda \in \mathcal{Z}_+(\tilde{\Omega}_{r_1})} \sum_{\mu \in \mathcal{Z}_+(\tilde{\Omega}_{r_2})} \frac{4\lambda\mu}{(\lambda^2 - \mu^2)\tilde{\Omega}'_{r_1}(\lambda)\tilde{\Omega}'_{r_2}(\mu)} \left(P_{r_2}(\Delta)((f * \sigma_{r_2}) * \Omega_{r_1}^\lambda) - P_{r_1}(\Delta)((f * \sigma_{r_1}) * \Omega_{r_2}^\mu) \right)$$

in the space $\mathcal{D}'(\mathbb{R}^n)$, where Δ is the Laplace operator in \mathbb{R}^n , P_r is an explicitly given polynomial of degree $[(n+5)/4]$, and Ω_r and Ω_r^λ are explicitly constructed radial distributions supported in the ball $|x| \leq r$. The proof uses the methods of harmonic analysis, as well as the theory of entire and special functions. By a similar technique, it is possible to obtain inversion formulas for other convolution operators with radial distributions.

Keywords: Compactly supported distributions, Fourier–Bessel transform, Two-radii theorem, Inversion formulas.

1. Introduction

The study of functions $f \in C(\mathbb{R}^2)$ with zero integrals over all sets congruent to a given compact set of positive Lebesgue measure (for example, with zero integrals over all discs of a fixed radius in \mathbb{R}^2) goes back to Pompeiu [17, 18]. Motivated by the works of Pompeiu, Nicolesco in his paper [16] presents the following erroneous statement concerning integrals over circles of a fixed radius: if a real-valued function $u(x, y)$ belongs to the class $C^s(\mathbb{R}^2)$ for some $s \in \mathbb{Z}_+$, r is a fixed positive number, and the function

$$v_s(x, y, r) = \int_0^{2\pi} u(x + r \cos \theta, y + r \sin \theta) e^{is\theta} d\theta$$

does not depend on (x, y) , then $u(x, y)$ is a solution to the equation

$$\left(\frac{\partial}{\partial x} + i \frac{\partial}{\partial y} \right)^s u(x, y) = \text{const.}$$

In particular, if $u \in C(\mathbb{R}^2)$ and u has constant integrals over all circles of fixed radius, then $u = \text{const}$. The impossibility of such a result is shown by the following proposition from a paper by Radon published back in 1917 (see [19, Sect. C]).

Proposition 1. *Let $r > 0$ be fixed, and let λr be an arbitrary positive zero of the Bessel function J_0 . Then, for any $k \in \mathbb{Z}$, the function*

$$\mathcal{I}_k(z) = J_k(\lambda\rho)e^{ik\varphi} \quad (\rho \text{ and } \varphi \text{ are the polar coordinates of } z)$$

has zero integrals over all circles of radius r .

Similar examples related to the zeros of the Bessel function $J_{n/2-1}$ can also be constructed for spherical means in \mathbb{R}^n for $n \geq 2$. This shows that knowing the averages of a function f over all spheres of the same radius is insufficient to reconstruct f uniquely. Subsequently, the class of functions $f \in C(\mathbb{R}^n)$ that have zero integrals over all spheres of fixed radius in \mathbb{R}^n was studied by many authors see [2, 23, 25, 27, 35, 36], and the references therein). A well-known result in this direction is the following analog of Delsarte's famous two-radius theorem [6] for harmonic functions.

Theorem 1 [7, 33]. *Let $r_1, r_2 \in (0, +\infty)$, let $\Upsilon_n = \{\gamma_1, \gamma_2, \dots\}$ be the sequence of all positive zeros of the function $J_{n/2-1}$ numbered in ascending order, and let M_n be the set of numbers of the form α/β , where $\alpha, \beta \in \Upsilon_n$.*

(1) *If $r_1/r_2 \notin M_n$, $f \in C(\mathbb{R}^n)$, and*

$$\int_{|x-y|=r_1} f(x)d\sigma(x) = \int_{|x-y|=r_2} f(x)d\sigma(x) = 0, \quad y \in \mathbb{R}^n, \quad (1.1)$$

($d\sigma$ is the area element), then $f = 0$.

(2) *If $r_1/r_2 \in M_n$, then there exists a nonzero real analytic function $f : \mathbb{R}^n \rightarrow \mathbb{C}$ satisfying the relations in (1.1).*

In terms of convolutions (see formula (2.2) below), Theorem 1 means that the operator

$$\mathcal{P}f = (f * \sigma_{r_1}, f * \sigma_{r_2}), \quad f \in C(\mathbb{R}^n) \quad (1.2)$$

is injective if and only if $r_1/r_2 \notin M_n$. Hereinafter, σ_r is a surface delta function concentrated on the sphere

$$S_r = \{x \in \mathbb{R}^n : |x| = r\},$$

that is,

$$\langle \sigma_r, \varphi \rangle = \int_{S_r} \varphi(x)d\sigma(x), \quad \varphi \in C(\mathbb{R}^n).$$

In this regard, Zalcman [34, Sect. 8] posed the problem of finding an explicit inversion formula for the operator \mathcal{P} under the condition $r_1/r_2 \notin M_n$ (see also [19, Sect. C]). A similar question for ball means values was studied by Berenstein, Yger, Taylor, and others (see [1, 3, 4]). Note that their methods are also applicable in the case of spherical means. In particular, the following local result is valid (see the proof of Theorem 9 in [1]).

Theorem 2. *Let*

$$r_1/r_2 \notin M_n, \quad R > r_1 + r_2, \quad B_R = \{x \in \mathbb{R}^n : |x| < R\},$$

and let $\{\varepsilon_k\}_{k=1}^\infty$ be a strictly increasing sequence of positive numbers with limit

$$R/(r_1 + r_2) - 1, \quad R_k = (r_1 + r_2)(1 + \varepsilon_k), \quad R_0 = 0.$$

Then, for all $r > 0$, $r \in [R_{k-1}, R_k)$, and every spherical harmonic Y of degree m on the unit sphere \mathbb{S}^{n-1} , one can explicitly construct two sequences \mathfrak{C}_l and \mathfrak{D}_l of compactly supported distributions in B_{R-r_1} and B_{R-r_2} , respectively, such that the following estimate holds for $l \geq cm^2$ and every function $f \in C^\infty(B_R)$:

$$\left| \int_{\mathbb{S}^{n-1}} f(r\sigma)Y(\sigma)d\sigma - \langle \mathfrak{C}_l, f * \sigma_{r_1} \rangle - \langle \mathfrak{D}_l, f * \sigma_{r_2} \rangle \right| \leq \frac{\gamma}{l} (R-r)^{-N} r^{-(n-3)/2} \max_{\substack{|\alpha| \leq N \\ |x| \leq R'_k}} \left| \frac{\partial^{|\alpha|}}{\partial x^\alpha} f(x) \right|, \quad (1.3)$$

where

$$N = [(n + 13)/2] + 1, \quad R'_k = (2R + R_k)/3,$$

and γ and c are positive constants depending on r_1 , r_2 , R , n , and ε_1 .

Here it is appropriate to make a few remarks. The distributions \mathfrak{C}_l and \mathfrak{D}_l have a very complex form and are constructed as inverse Fourier–Bessel transforms to some linear combinations of products of rational and Bessel functions (see the proof of Proposition 8 and Theorem 9 in [1]). Further, every function $f \in C^\infty(B_R)$ can be represented as a Fourier series

$$f(x) = \sum_{m=0}^\infty \sum_{j=1}^{d_m} f_{m,j}(r) Y_j^{(m)}(\sigma), \quad x = r\sigma, \quad \sigma \in \mathbb{S}^{n-1}, \quad (1.4)$$

converging in the space $C^\infty(B_R)$, where $\{Y_j^{(m)}\}_{j=1}^{d_m}$ is a fixed orthonormal basis in the space of spherical harmonics of degree m on \mathbb{S}^{n-1} ,

$$f_{m,j}(r) = \int_{\mathbb{S}^{n-1}} f(r\sigma) \overline{Y_j^{(m)}(\sigma)} d\sigma$$

(see, for example, [10, Ch. 1, Sect. 2, Proposition 2.7], [24, Sect. 1]). Therefore, estimate (1.3) as $l \rightarrow \infty$ and expansion (1.4) imply the reconstruction of a function $f \in C^\infty(B_R)$ from its spherical means $f * \sigma_{r_1}$ and $f * \sigma_{r_2}$ in the ball B_R . The transition to the class $C(B_R)$ can be done by smoothing f by convolutions of the form $f * \varphi_\varepsilon$, where $\varphi_\varepsilon \in C^\infty(\mathbb{R}^n)$, $\text{supp } \varphi_\varepsilon \subset B_\varepsilon$ (see [1, Sect. 3]).

The above remarks and Theorem 2 for $R = \infty$ give a procedure for finding a function from its two spherical means. However, “explicit” inversion formulas for the operator (1.2) were unknown. This work aims to solve this problem.

2. Statement of the main result

In what follows, as usual, \mathbb{C}^n is an n -dimensional complex space with the Hermitian scalar product

$$(\zeta, \varsigma) = \sum_{j=1}^n \zeta_j \bar{\varsigma}_j, \quad \zeta = (\zeta_1, \dots, \zeta_n), \quad \varsigma = (\varsigma_1, \dots, \varsigma_n),$$

$\mathcal{D}'(\mathbb{R}^n)$ and $\mathcal{E}'(\mathbb{R}^n)$ are the spaces of distributions and compactly supported distributions on \mathbb{R}^n , respectively.

The Fourier–Laplace transform of a distribution $T \in \mathcal{E}'(\mathbb{R}^n)$ is the entire function

$$\widehat{T}(\zeta) = \langle T(x), e^{-i(\zeta, x)} \rangle, \quad \zeta \in \mathbb{C}^n.$$

In this case, \widehat{T} grows on \mathbb{R}^n not faster than a polynomial and

$$\langle \widehat{T}, \psi \rangle = \langle T, \widehat{\psi} \rangle, \quad \psi \in \mathcal{S}(\mathbb{R}^n), \quad (2.1)$$

where $\mathcal{S}(\mathbb{R}^n)$ is the Schwartz space of rapidly decreasing functions from $C^\infty(\mathbb{R}^n)$ (see [13, Ch. 7]). If $T_1, T_2 \in \mathcal{D}'(\mathbb{R}^n)$ and at least one of these distributions has compact support, then their convolution $T_1 * T_2$ is a distribution in $\mathcal{D}'(\mathbb{R}^n)$ acting according to the rule

$$\langle T_1 * T_2, \varphi \rangle = \langle T_2(y), \langle T_1(x), \varphi(x + y) \rangle \rangle, \quad \varphi \in \mathcal{D}(\mathbb{R}^n), \quad (2.2)$$

where $\mathcal{D}(\mathbb{R}^n)$ is the space of finite infinitely differentiable functions on \mathbb{R}^n . For $T_1, T_2 \in \mathcal{E}'(\mathbb{R}^n)$, the Borel formula

$$\widehat{T_1 * T_2} = \widehat{T_1} \widehat{T_2} \quad (2.3)$$

is valid.

Let $\mathcal{E}'_{\text{q}}(\mathbb{R}^n)$ be the space of radial (invariant under rotations of the space \mathbb{R}^n) distributions in $\mathcal{E}'(\mathbb{R}^n)$, $n \geq 2$. The simplest example of distribution in the class $\mathcal{E}'_{\text{q}}(\mathbb{R}^n)$ is the Dirac delta function δ with support at zero. We set

$$\mathbf{I}_\nu(z) = \frac{J_\nu(z)}{z^\nu}, \quad \nu \in \mathbb{C}.$$

The spherical transform \widetilde{T} of a distribution $T \in \mathcal{E}'_{\text{q}}(\mathbb{R}^n)$ is defined as

$$\widetilde{T}(z) = \langle T, \varphi_z \rangle, \quad z \in \mathbb{C}, \quad (2.4)$$

where φ_z is a spherical function on \mathbb{R}^n , i.e.,

$$\varphi_z(x) = 2^{n/2-1} \Gamma\left(\frac{n}{2}\right) \mathbf{I}_{n/2-1}(z|x|), \quad x \in \mathbb{R}^n$$

(see [9, Ch. 4]). The function φ_z is uniquely determined by the following conditions:

- (1) φ_z is radial and $\varphi_z(0) = 1$;
- (2) φ_z satisfies the Helmholtz differential equation

$$\Delta(\varphi_z) + z^2 \varphi_z = 0. \quad (2.5)$$

We note that \widetilde{T} is an even entire function of exponential type and the Fourier transform \widehat{T} is expressed in terms of \widetilde{T} as

$$\widehat{T}(\zeta) = \widetilde{T}\left(\sqrt{\zeta_1^2 + \dots + \zeta_n^2}\right), \quad \zeta \in \mathbb{C}^n. \quad (2.6)$$

The set of all zeros of the function \widetilde{T} that lie in the half-plane $\operatorname{Re} z \geq 0$ and do not belong to the negative part of the imaginary axis will be denoted by $\mathcal{Z}_+(\widetilde{T})$.

For $T = \sigma_r$, we have (see [27, Part 2, Ch. 3, formula (3.90)])

$$\widetilde{\sigma}_r(z) = (2\pi)^{n/2} r^{n-1} \mathbf{I}_{n/2-1}(rz). \quad (2.7)$$

Hence, by the formula

$$\mathbf{I}'_\nu(z) = -z\mathbf{I}_{\nu+1}(z) \tag{2.8}$$

(see [12, Ch. 7, Sect. 7.2.8, formula (51)]), we find

$$\tilde{\sigma}'_r(z) = -(2\pi)^{n/2}r^{n+1}z\mathbf{I}_{n/2}(rz). \tag{2.9}$$

Using the well-known properties of zeros of Bessel functions (see, for example, [12, Ch. 7, Sect. 7.9]), one can obtain the corresponding information about the set $\mathcal{Z}_+(\tilde{\sigma}_r)$. In particular, all zeros of $\tilde{\sigma}_r$ are simple, belong to $\mathbb{R}\setminus\{0\}$, and

$$\mathcal{Z}_+(\tilde{\sigma}_r) = \left\{ \frac{\gamma_1}{r}, \frac{\gamma_2}{r}, \dots \right\}. \tag{2.10}$$

In addition, since the functions $J_{n/2-1}$ and $J_{n/2}$ do not have common zeros on $\mathbb{R}\setminus\{0\}$, the function

$$\sigma_r^\lambda(x) = -\frac{1}{r\lambda^2} \frac{\mathbf{I}_{n/2-1}(\lambda|x|)}{\mathbf{I}_{n/2}(\lambda r)} \chi_r(x), \quad \lambda \in \mathcal{Z}_+(\tilde{\sigma}_r),$$

is well defined, where χ_r is the indicator of the ball B_r .

Let

$$P_r(z) = \prod_{j=1}^m \left(z - \left(\frac{\gamma_j}{r} \right)^2 \right), \quad m = \left[\frac{n+5}{4} \right], \tag{2.11}$$

$$\Omega_r = P_r(\Delta)\sigma_r. \tag{2.12}$$

Then, by the formula

$$p(\widetilde{\Delta})T(z) = p(-z^2)\tilde{T}(z) \quad (p \text{ is an algebraic polynomial}), \tag{2.13}$$

we have

$$\tilde{\Omega}_r(z) = P_r(-z^2)\tilde{\sigma}_r(z), \tag{2.14}$$

$$\mathcal{Z}_+(\tilde{\Omega}_r) = \left\{ \frac{\gamma_1}{r}, \frac{\gamma_2}{r}, \dots \right\} \cup \left\{ \frac{i\gamma_1}{r}, \frac{i\gamma_2}{r}, \dots, \frac{i\gamma_m}{r} \right\}, \tag{2.15}$$

and all zeros of $\tilde{\Omega}_r$ are simple. Besides,

$$\mathcal{Z}_+(\tilde{\Omega}_{r_1}) \cap \mathcal{Z}_+(\tilde{\Omega}_{r_2}) = \emptyset \quad \Leftrightarrow \quad \frac{r_1}{r_2} \notin M_n. \tag{2.16}$$

For $\lambda \in \mathcal{Z}_+(\tilde{\Omega}_r)$, we set

$$\Omega_r^\lambda = P_r(\Delta)\sigma_r^\lambda \tag{2.17}$$

if $\lambda \in \mathcal{Z}_+(\tilde{\sigma}_r)$ and

$$\Omega_r^\lambda = Q_{r,\lambda}(\Delta)\sigma_r \tag{2.18}$$

if $P_r(-\lambda^2) = 0$, where

$$Q_{r,\lambda}(z) = -\frac{P_r(z)}{z + \lambda^2}. \tag{2.19}$$

The main result of this work is the following theorem.

Theorem 3. *Let*

$$\frac{r_1}{r_2} \notin M_n, \quad f \in \mathcal{D}'(\mathbb{R}^n), \quad n \geq 2.$$

Then

$$f = \sum_{\lambda \in \mathcal{Z}_+(\tilde{\Omega}_{r_1})} \sum_{\mu \in \mathcal{Z}_+(\tilde{\Omega}_{r_2})} \frac{4\lambda\mu}{(\lambda^2 - \mu^2)\tilde{\Omega}'_{r_1}(\lambda)\tilde{\Omega}'_{r_2}(\mu)} \left(P_{r_2}(\Delta)((f * \sigma_{r_2}) * \Omega_{r_1}^\lambda) - P_{r_1}(\Delta)((f * \sigma_{r_1}) * \Omega_{r_2}^\mu) \right), \tag{2.20}$$

where the series (2.20) converges unconditionally in the space $\mathcal{D}'(\mathbb{R}^n)$.

Equality (2.20) reconstruct a distribution $f \in \mathcal{D}'(\mathbb{R}^n)$ from its known convolutions $f * \sigma_{r_1}$ and $f * \sigma_{r_2}$ (see (2.11), (2.14), (2.15), and (2.17)–(2.19)). Thus, Theorem 3 gives a solution to the Zalcman problem formulated above. Note that there is great arbitrariness in the choice of polynomials P_{r_1} and P_{r_2} in formula (2.20) (see the proof of Corollary 1 and Lemma 5 in Section 3). In particular, they can be defined fully explicitly without using the zeros of the function $J_{n/2-1}$. For other results related to the inversion of the spherical mean operator, see [5, 8, 11, 20, 21, 26, 28–32].

3. Auxiliary statements

Let us first describe the properties of the functions \mathbf{I}_ν , which we will need later.

Lemma 1. (1) *The following inequality holds for $\nu > -1/2$ and $z \in \mathbb{C}$:*

$$|\mathbf{I}_\nu(z)| \leq \frac{e^{|\operatorname{Im} z|}}{2^\nu \Gamma(\nu + 1)}. \tag{3.1}$$

(2) *If $\nu \in \mathbb{R}$, then*

$$|\mathbf{I}_\nu(z)| \sim \frac{1}{\sqrt{2\pi}} \frac{e^{|\operatorname{Im} z|}}{|z|^{\nu+1/2}}, \quad \operatorname{Im} z \rightarrow \infty. \tag{3.2}$$

(3) *Let $\nu > -1$ and let $\{\gamma_{\nu,j}\}_{j=1}^\infty$ be the sequence of all positive zeros of the function \mathbf{I}_ν numbered in ascending order. Then*

$$\gamma_{\nu,j} = \pi \left(j + \frac{\nu}{2} - \frac{1}{4} \right) + O\left(\frac{1}{j}\right), \quad j \rightarrow \infty. \tag{3.3}$$

In addition,

$$\lim_{j \rightarrow \infty} (\gamma_{\nu,j})^{\nu+3/2} |\mathbf{I}_{\nu+1}(\gamma_{\nu,j})| = \sqrt{\frac{2}{\pi}}. \tag{3.4}$$

P r o o f. (1) By the Poisson integral representation [12, Ch. 7, Sect. 7.12, formula (8)], we have

$$\mathbf{I}_\nu(z) = \frac{2^{1-\nu}}{\sqrt{\pi}\Gamma(\nu + 1/2)} \int_0^1 \cos(uz)(1 - u^2)^{\nu-1/2} du.$$

Hence,

$$|\mathbf{I}_\nu(z)| \leq \frac{2^{1-\nu}}{\sqrt{\pi}\Gamma(\nu + 1/2)} \int_0^1 e^{u|\operatorname{Im} z|}(1 - u^2)^{\nu-1/2} du$$

$$\leq \frac{2^{1-\nu}}{\sqrt{\pi}\Gamma(\nu + 1/2)} \frac{1}{2} B\left(\frac{1}{2}, \nu + \frac{1}{2}\right) e^{|\operatorname{Im} z|} = \frac{e^{|\operatorname{Im} z|}}{2^\nu \Gamma(\nu + 1)},$$

which is required.

(2) The asymptotic expansion of Bessel functions [12, Ch. 7, Sect. 7.13.1, formula (3)] implies the equality

$$\mathbf{I}_\nu(z) = \sqrt{\frac{2}{\pi}} z^{-\nu-1/2} \left(\cos\left(z - \frac{\pi\nu}{2} - \frac{\pi}{4}\right) + O\left(\frac{e^{|\operatorname{Im} z|}}{|z|}\right) \right), \quad z \rightarrow \infty, \quad -\pi < \arg z < \pi. \quad (3.5)$$

Considering that

$$|\cos w| \sim \frac{e^{|\operatorname{Im} w|}}{2}, \quad \operatorname{Im} w \rightarrow \infty,$$

by (3.5), we obtain (3.2).

(3) The asymptotic behavior (3.3) for the zeros of \mathbf{I}_ν is well known (see, for example, [25, Ch. 7, formula (7.9)]). Then

$$\cos\left(\gamma_{\nu,j} - \frac{\pi\nu}{2} - \frac{\pi}{4}\right) = \cos\left(\pi j - \frac{\pi}{2} + O\left(\frac{1}{j}\right)\right) = O\left(\frac{1}{j}\right), \quad j \rightarrow \infty.$$

It follows that

$$\lim_{j \rightarrow \infty} \left| \sin\left(\gamma_{\nu,j} - \frac{\pi\nu}{2} - \frac{\pi}{4}\right) \right| = 1.$$

Using this relation and the equality

$$\mathbf{I}_{\nu+1}(z) = \sqrt{\frac{2}{\pi}} z^{-\nu-3/2} \left(\sin\left(z - \frac{\pi\nu}{2} - \frac{\pi}{4}\right) + O\left(\frac{e^{|\operatorname{Im} z|}}{|z|}\right) \right), \quad z \rightarrow \infty, \quad -\pi < \arg z < \pi,$$

(see (3.5)), we arrive at (3.4). □

Corollary 1. For all $r > 0$,

$$\sum_{\lambda \in \mathcal{Z}_+(\tilde{\Omega}_r)} \frac{1}{|\tilde{\Omega}'_r(\lambda)|} < +\infty. \quad (3.6)$$

P r o o f. Using (2.14) and (2.9), we find

$$\tilde{\Omega}'_r(\lambda) = P_r(-\lambda^2)\tilde{\sigma}'_r(\lambda) - 2\lambda P'_r(-\lambda^2)\tilde{\sigma}_r(\lambda) = -(2\pi)^{n/2}r^{n+1}\lambda P_r(-\lambda^2)\mathbf{I}_{n/2}(r\lambda) - 2\lambda P'_r(-\lambda^2)\tilde{\sigma}_r(\lambda).$$

Now, from (2.10) and (2.15), we have

$$\sum_{\lambda \in \mathcal{Z}_+(\tilde{\Omega}_r)} \frac{1}{|\tilde{\Omega}'_r(\lambda)|} = \sum_{j=1}^m \frac{1}{|\tilde{\Omega}'_r(i\gamma_j/r)|} + \frac{1}{(2\pi)^{n/2}r^n} \sum_{j=1}^{\infty} \frac{1}{\gamma_j |P_r(-\gamma_j^2/r^2)| |\mathbf{I}_{n/2}(\gamma_j)|}.$$

This series is comparable with the convergent series

$$\sum_{j=1}^{\infty} \frac{1}{j^{2m-(n-1)/2}}$$

(see (2.11), (3.3), and (3.4)). Hence, we obtain the required assertion. □

Lemma 2. *Let $g : \mathbb{C} \rightarrow \mathbb{C}$ be an even entire function, and let $g(\lambda) = 0$ for some $\lambda \in \mathbb{C}$. Then*

$$\left| \frac{\lambda g(z)}{z^2 - \lambda^2} \right| \leq \max_{|\zeta - z| \leq 2} |g(\zeta)|, \quad z \in \mathbb{C}; \quad (3.7)$$

the left-hand side in (3.7) for $z = \pm\lambda$ is extended by continuity.

P r o o f. We have

$$\left| \frac{2\lambda g(z)}{z^2 - \lambda^2} \right| = \left| \frac{g(z)}{z - \lambda} - \frac{g(z)}{z + \lambda} \right| \leq \left| \frac{g(z)}{z - \lambda} \right| + \left| \frac{g(z)}{z + \lambda} \right|. \quad (3.8)$$

Let us estimate the first term on the right-hand side of (3.8).

If $|z - \lambda| > 1$, then

$$\left| \frac{g(z)}{z - \lambda} \right| \leq |g(z)| \leq \max_{|\zeta - z| \leq 2} |g(\zeta)|. \quad (3.9)$$

Assume that $|z - \lambda| \leq 1$. Then, applying the maximum-modulus principle to the entire function $g(\zeta)/(\zeta - \lambda)$, we obtain

$$\left| \frac{g(z)}{z - \lambda} \right| \leq \max_{|\zeta - \lambda| \leq 1} \left| \frac{g(\zeta)}{\zeta - \lambda} \right| = \max_{|\zeta - \lambda| = 1} |g(\zeta)|.$$

Considering that the circle $|\zeta - \lambda| = 1$ is contained in the disc $|\zeta - z| \leq 2$, we arrive at the estimate

$$\left| \frac{g(z)}{z - \lambda} \right| \leq \max_{|\zeta - z| \leq 2} |g(\zeta)|, \quad (3.10)$$

which is valid for all $z \in \mathbb{C}$ (see (3.9)).

Similarly,

$$\left| \frac{g(z)}{z + \lambda} \right| \leq \max_{|\zeta - z| \leq 2} |g(\zeta)|, \quad z \in \mathbb{C}, \quad (3.11)$$

because $g(-\lambda) = 0$. From (3.10), (3.11), and (3.8) the required assertion follows. \square

Lemma 3. *The function σ_r^λ satisfies the equation*

$$\Delta(\sigma_r^\lambda) + \lambda^2 \sigma_r^\lambda = -\sigma_r, \quad \lambda \in \mathcal{Z}_+(\tilde{\sigma}_r). \quad (3.12)$$

P r o o f. For every function $\varphi \in \mathcal{D}(\mathbb{R}^n)$, we have

$$\begin{aligned} \langle \Delta(\sigma_r^\lambda) + \lambda^2 \sigma_r^\lambda, \varphi \rangle &= \langle \sigma_r^\lambda, (\Delta + \lambda^2)\varphi \rangle \\ &= -\frac{1}{r\lambda^2} \int_{|x| \leq r} \frac{\mathbf{I}_{n/2-1}(\lambda|x|)}{\mathbf{I}_{n/2}(\lambda r)} \Delta\varphi(x) dx - \frac{1}{r} \int_{|x| \leq r} \frac{\mathbf{I}_{n/2-1}(\lambda|x|)}{\mathbf{I}_{n/2}(\lambda r)} \varphi(x) dx. \end{aligned}$$

We apply Green's formula

$$\int_G (v\Delta u - u\Delta v) dx = \int_{\partial G} \left(v \frac{\partial u}{\partial \mathbf{n}} - u \frac{\partial v}{\partial \mathbf{n}} \right) d\sigma$$

to the former integral (see, for example, [22, Ch. 5, Sect. 21.2]). Since $\lambda \in \mathcal{Z}_+(\tilde{\sigma}_r)$, we have

$$\begin{aligned} \langle \Delta(\sigma_r^\lambda) + \lambda^2 \sigma_r^\lambda, \varphi \rangle &= -\frac{1}{r\lambda^2} \int_{|x| \leq r} \Delta \left(\frac{\mathbf{I}_{n/2-1}(\lambda|x|)}{\mathbf{I}_{n/2}(\lambda r)} \right) \varphi(x) dx \\ &+ \frac{1}{r\lambda^2} \int_{S_r} \varphi(x) \frac{\partial}{\partial \mathbf{n}} \left(\frac{\mathbf{I}_{n/2-1}(\lambda|x|)}{\mathbf{I}_{n/2}(\lambda r)} \right) d\sigma(x) - \frac{1}{r} \int_{|x| \leq r} \frac{\mathbf{I}_{n/2-1}(\lambda|x|)}{\mathbf{I}_{n/2}(\lambda r)} \varphi(x) dx. \end{aligned}$$

Hence, by (2.5), we obtain

$$\langle \Delta(\sigma_r^\lambda) + \lambda^2 \sigma_r^\lambda, \varphi \rangle = \frac{1}{r\lambda^2} \int_{S_r} \varphi(x) \frac{\partial}{\partial \mathbf{n}} \left(\frac{\mathbf{I}_{n/2-1}(\lambda|x|)}{\mathbf{I}_{n/2}(\lambda r)} \right) d\sigma(x).$$

Now, using the formula

$$\frac{\partial}{\partial \mathbf{n}}(f(|x|)) = f'(|x|), \quad \mathbf{n} = \frac{x}{|x|},$$

and relation (2.8), we find

$$\langle \Delta(\sigma_r^\lambda) + \lambda^2 \sigma_r^\lambda, \varphi \rangle = -\frac{1}{r} \int_{S_r} \varphi(x) |x| \frac{\mathbf{I}_{n/2}(\lambda|x|)}{\mathbf{I}_{n/2}(\lambda r)} d\sigma(x) = -\int_{S_r} \varphi(x) d\sigma(x) = -\langle \sigma_r, \varphi \rangle.$$

This proves equality (3.12). □

Remark 1. From (2.13) and the injectivity of the spherical transform, it follows that, for distributions $U, T \in \mathcal{E}'_q(\mathbb{R}^n)$ and $\lambda \in \mathcal{Z}_+(\tilde{T})$,

$$\Delta U + \lambda^2 U = -T \quad \Leftrightarrow \quad \tilde{U}(z) = \frac{\tilde{T}(z)}{z^2 - \lambda^2}. \tag{3.13}$$

Therefore, relation (3.12) implies the equality

$$\tilde{\sigma}_r^\lambda(z) = \frac{\tilde{\sigma}_r(z)}{z^2 - \lambda^2}, \quad \lambda \in \mathcal{Z}_+(\tilde{\sigma}_r). \tag{3.14}$$

Lemma 4. *Let $\lambda \in \mathcal{Z}_+(\tilde{\Omega}_r)$. Then*

$$\tilde{\Omega}_r^\lambda(z) = \frac{\tilde{\Omega}_r(z)}{z^2 - \lambda^2}. \tag{3.15}$$

P r o o f. Formula (3.15) easily follows from (2.13) and Remark 1. Indeed, if $\lambda \in \mathcal{Z}_+(\tilde{\sigma}_r)$, then, by (2.17), (2.13), (3.14), and (2.14), we have

$$\tilde{\Omega}_r^\lambda(z) = P_r(-z^2) \tilde{\sigma}_r^\lambda(z) = \frac{P_r(-z^2) \tilde{\sigma}_r(z)}{z^2 - \lambda^2} = \frac{\tilde{\Omega}_r(z)}{z^2 - \lambda^2}.$$

Similarly, if $P_r(-\lambda^2) = 0$, then

$$\tilde{\Omega}_r^\lambda(z) = Q_{r,\lambda}(-z^2) \tilde{\sigma}_r(z) = \frac{P_r(-z^2) \tilde{\sigma}_r(z)}{z^2 - \lambda^2} = \frac{\tilde{\Omega}_r(z)}{z^2 - \lambda^2}$$

(see (2.18), (2.19), (2.13), and (2.14)). □

Lemma 5. *Let*

$$\Psi_r^\lambda = \frac{2\lambda}{\tilde{\Omega}'_r(\lambda)} \Omega_r^\lambda, \quad \lambda \in \mathcal{Z}_+(\tilde{\Omega}_r). \tag{3.16}$$

Then

$$\sum_{\lambda \in \mathcal{Z}_+(\tilde{\Omega}_r)} \Psi_r^\lambda = \delta, \tag{3.17}$$

where the series in (3.17) converges unconditionally in the space $\mathcal{D}'(\mathbb{R}^n)$.

P r o o f. For an arbitrary function $\varphi \in \mathcal{D}(\mathbb{R}^n)$, we define a function $\psi \in \mathcal{S}(\mathbb{R}^n)$ as follows:

$$\psi(y) = \frac{1}{(2\pi)^n} \int_{\mathbb{R}^n} \varphi(x) e^{i(x,y)} dx, \quad y \in \mathbb{R}^n.$$

Then (see (2.1), (2.6), and (3.15))

$$\langle \Psi_r^\lambda, \varphi \rangle = \langle \Psi_r^\lambda, \widehat{\psi} \rangle = \langle \widehat{\Psi}_r^\lambda, \psi \rangle = \int_{\mathbb{R}^n} \psi(x) \widetilde{\Psi}_r^\lambda(|x|) dx = \frac{2}{\widetilde{\Omega}_r'(\lambda)} \int_{\mathbb{R}^n} \psi(x) \frac{\lambda \widetilde{\Omega}_r(|x|)}{|x|^2 - \lambda^2} dx.$$

Using this representation and Lemma 2, we get

$$|\langle \Psi_r^\lambda, \varphi \rangle| \leq \frac{2}{|\widetilde{\Omega}_r'(\lambda)|} \int_{\mathbb{R}^n} |\psi(x)| \max_{|\zeta - |x|| \leq 2} |\widetilde{\Omega}_r(\zeta)| dx.$$

From (2.14), (2.7), and (3.1), we obtain

$$\begin{aligned} \max_{|\zeta - |x|| \leq 2} |\widetilde{\Omega}_r(\zeta)| &= (2\pi)^{n/2} r^{n-1} \max_{|\zeta - |x|| \leq 2} |P_r(-\zeta^2)| |\mathbf{I}_{n/2-1}(r\zeta)| \\ &\leq \frac{2\pi^{n/2} r^{n-1}}{\Gamma(n/2)} \max_{|\zeta - |x|| \leq 2} |P_r(-\zeta^2)| \cdot e^{r|\operatorname{Im}\zeta|} \leq \frac{2\pi^{n/2} r^{n-1} e^{2r}}{\Gamma(n/2)} \max_{|\zeta - |x|| \leq 2} |P_r(-\zeta^2)|. \end{aligned}$$

Therefore,

$$|\langle \Psi_r^\lambda, \varphi \rangle| \leq \frac{4\pi^{n/2} r^{n-1} e^{2r}}{\Gamma(n/2) |\widetilde{\Omega}_r'(\lambda)|} \int_{\mathbb{R}^n} |\psi(x)| \max_{|\zeta - |x|| \leq 2} |P_r(-\zeta^2)| dx. \tag{3.18}$$

This inequality and Corollary 1 show that the series in (3.17) converges unconditionally in the space $\mathcal{D}'(\mathbb{R}^n)$ to some distribution f supported in \overline{B}_r . By Lemma 4, the spherical transform of this distribution satisfies the equality

$$\widetilde{f}(z) = \sum_{\lambda \in \mathcal{Z}_+(\widetilde{\Omega}_r)} \widetilde{\Psi}_r^\lambda(z) = \sum_{\lambda \in \mathcal{Z}_+(\widetilde{\Omega}_r)} \frac{2\lambda}{\widetilde{\Omega}_r'(\lambda)} \frac{\widetilde{\Omega}_r(z)}{z^2 - \lambda^2}. \tag{3.19}$$

In this case, if $\mu \in \mathcal{Z}_+(\widetilde{\Omega}_r)$, then

$$\widetilde{f}(\mu) = \frac{2\mu}{\widetilde{\Omega}_r'(\mu)} \lim_{z \rightarrow \mu} \frac{\widetilde{\Omega}_r(z)}{z^2 - \mu^2} = 1. \tag{3.20}$$

Further, since $\widetilde{f}(z) - 1$ and $\widetilde{\Omega}_r(z)$ are even entire functions of exponential type, by (3.20) and the simplicity of the zeros of $\widetilde{\Omega}_r$, their ratio

$$h(z) = \frac{\widetilde{f}(z) - 1}{\widetilde{\Omega}_r(z)}$$

is an entire function of at most first order (see [15, Ch. 1, Sect. 9, Corollary of Theorem 12]). For

$\operatorname{Im} z = \pm \operatorname{Re} z$, $z \neq 0$, it is estimated as follows:

$$\begin{aligned} |h(z)| &\leq \frac{|\tilde{f}(z)|}{|\tilde{\Omega}_r(z)|} + \frac{1}{|\tilde{\Omega}_r(z)|} \\ &= \left| \sum_{\lambda \in \mathcal{Z}_+(\tilde{\Omega}_r)} \frac{1}{\tilde{\Omega}'_r(\lambda)} \left(\frac{1}{z-\lambda} - \frac{1}{z+\lambda} \right) \right| + \frac{1}{(2\pi)^{n/2} r^{n-1} |P_r(-z^2) \mathbf{I}_{n/2-1}(rz)|} \\ &\leq \sum_{\lambda \in \mathcal{Z}_+(\tilde{\Omega}_r)} \frac{1}{|\tilde{\Omega}'_r(\lambda)|} \left(\frac{1}{|z-\lambda|} + \frac{1}{|z+\lambda|} \right) + \frac{1}{(2\pi)^{n/2} r^{n-1} |P_r(-z^2) \mathbf{I}_{n/2-1}(rz)|} \\ &\leq \frac{2\sqrt{2}}{|z|} \sum_{\lambda \in \mathcal{Z}_+(\tilde{\Omega}_r)} \frac{1}{|\tilde{\Omega}'_r(\lambda)|} + \frac{1}{(2\pi)^{n/2} r^{n-1} |P_r(-z^2) \mathbf{I}_{n/2-1}(rz)|}. \end{aligned}$$

It can be seen from this estimate and relations (3.6) and (3.2) that

$$\lim_{\substack{z \rightarrow \infty \\ \operatorname{Im} z = \pm \operatorname{Re} z}} h(z) = 0. \tag{3.21}$$

Then, according to the Phragmén–Lindelöf principle, h is bounded on \mathbb{C} . Now it follows from (3.21) and Liouville’s theorem that $h = 0$. Hence, $f = 1$, i.e., $f = \delta$. Thus, Lemma 5 is proved. \square

Lemma 6. *Let $\lambda \in \mathcal{Z}_+(\tilde{\Omega}_{r_1})$, $\mu \in \mathcal{Z}_+(\tilde{\Omega}_{r_2})$. Then*

$$(\lambda^2 - \mu^2) \Psi_{r_1}^\lambda * \Psi_{r_2}^\mu = \frac{4\lambda\mu}{\tilde{\Omega}'_{r_1}(\lambda)\tilde{\Omega}'_{r_2}(\mu)} \left(\Omega_{r_2} * \Omega_{r_1}^\lambda - \Omega_{r_1} * \Omega_{r_2}^\mu \right). \tag{3.22}$$

P r o o f. By (3.15), (3.13), and (3.16), we have

$$(\Delta + \lambda^2) \left(\Psi_{r_1}^\lambda \right) = -\frac{2\lambda}{\tilde{\Omega}'_{r_1}(\lambda)} \Omega_{r_1}, \tag{3.23}$$

$$(\Delta + \mu^2) \left(\Psi_{r_2}^\mu \right) = -\frac{2\mu}{\tilde{\Omega}'_{r_2}(\mu)} \Omega_{r_2}. \tag{3.24}$$

From (3.23), (3.16) and the permutation of the differentiation operator with convolution, we obtain

$$(\Delta + \lambda^2) \left(\Psi_{r_1}^\lambda * \Psi_{r_2}^\mu \right) = \frac{-4\lambda\mu}{\tilde{\Omega}'_{r_1}(\lambda)\tilde{\Omega}'_{r_2}(\mu)} \Omega_{r_1} * \Omega_{r_2}^\mu.$$

Similarly, it follows from (3.24) that

$$-(\Delta + \mu^2) \left(\Psi_{r_1}^\lambda * \Psi_{r_2}^\mu \right) = \frac{4\lambda\mu}{\tilde{\Omega}'_{r_1}(\lambda)\tilde{\Omega}'_{r_2}(\mu)} \Omega_{r_2} * \Omega_{r_1}^\lambda.$$

Adding the last two equalities, we arrive at relation (3.22). \square

4. Proof of Theorem 3

By Lemma 5, we obtain

$$\sum_{\lambda \in \mathcal{Z}_+(\tilde{\Omega}_{r_1})} \Psi_{r_1}^\lambda = \delta, \quad \sum_{\mu \in \mathcal{Z}_+(\tilde{\Omega}_{r_2})} \Psi_{r_2}^\mu = \delta. \tag{4.1}$$

We claim that

$$\sum_{\lambda \in \mathcal{Z}_+(\tilde{\Omega}_{r_1})} \sum_{\mu \in \mathcal{Z}_+(\tilde{\Omega}_{r_2})} \Psi_{r_1}^\lambda * \Psi_{r_2}^\mu = \delta, \tag{4.2}$$

where the series in (4.2) converges unconditionally in the space $\mathcal{D}'(\mathbb{R}^n)$. Let $\varphi \in \mathcal{D}(\mathbb{R}^n)$, $\psi \in \mathcal{S}(\mathbb{R}^n)$, and let $\varphi = \widehat{\psi}$. For $\lambda \in \mathcal{Z}_+(\tilde{\Omega}_{r_1})$ and $\mu \in \mathcal{Z}_+(\tilde{\Omega}_{r_2})$, we have (see (2.3) and the proof of estimate (3.18))

$$\begin{aligned} |\langle \Psi_{r_1}^\lambda * \Psi_{r_2}^\mu, \varphi \rangle| &= |\langle \Psi_{r_1}^\lambda * \Psi_{r_2}^\mu, \widehat{\psi} \rangle| = |\langle \widehat{\Psi_{r_1}^\lambda} \widehat{\Psi_{r_2}^\mu}, \psi \rangle| = \left| \int_{\mathbb{R}^n} \psi(x) \widehat{\Psi_{r_1}^\lambda}(|x|) \widehat{\Psi_{r_2}^\mu}(|x|) dx \right| \\ &= \frac{4}{|\tilde{\Omega}'_{r_1}(\lambda) \tilde{\Omega}'_{r_2}(\mu)|} \left| \int_{\mathbb{R}^n} \psi(x) \frac{\lambda \tilde{\Omega}_{r_1}(|x|)}{|x|^2 - \lambda^2} \frac{\mu \tilde{\Omega}_{r_2}(|x|)}{|x|^2 - \mu^2} dx \right| \\ &\leq \frac{16\pi^n (r_1 r_2)^{n-1} e^{2(r_1+r_2)}}{|\tilde{\Omega}'_{r_1}(\lambda) \tilde{\Omega}'_{r_2}(\mu)| \Gamma^2(n/2)} \int_{\mathbb{R}^n} |\psi(x)| \max_{|\zeta-|x|| \leq 2} |P_{r_1}(-\zeta^2)| \max_{|\zeta-|x|| \leq 2} |P_{r_2}(-\zeta^2)| dx. \end{aligned}$$

This and (3.6) imply that

$$\sum_{\lambda \in \mathcal{Z}_+(\tilde{\Omega}_{r_1})} \left(\sum_{\mu \in \mathcal{Z}_+(\tilde{\Omega}_{r_2})} |\langle \Psi_{r_1}^\lambda * \Psi_{r_2}^\mu, \varphi \rangle| \right) < \infty.$$

Therefore (see, for example, [14, Ch. 1, Theorem 1.24]), the series in (4.2) converges unconditionally in the space $\mathcal{D}'(\mathbb{R}^n)$. In addition (see (2.2) and (4.1)),

$$\begin{aligned} \sum_{\lambda \in \mathcal{Z}_+(\tilde{\Omega}_{r_1})} \sum_{\mu \in \mathcal{Z}_+(\tilde{\Omega}_{r_2})} \langle \Psi_{r_1}^\lambda * \Psi_{r_2}^\mu, \varphi \rangle &= \sum_{\lambda \in \mathcal{Z}_+(\tilde{\Omega}_{r_1})} \left(\sum_{\mu \in \mathcal{Z}_+(\tilde{\Omega}_{r_2})} \langle \Psi_{r_2}^\mu(y), \langle \Psi_{r_1}^\lambda(x), \varphi(x+y) \rangle \rangle \right) \\ &= \sum_{\lambda \in \mathcal{Z}_+(\tilde{\Omega}_{r_1})} \langle \Psi_{r_1}^\lambda(x), \varphi(x) \rangle = \varphi(0), \end{aligned}$$

which proves (4.2).

Convolving both parts of (4.2) with f and taking into account the separate continuity of the convolution of $f \in \mathcal{D}'(\mathbb{R}^n)$ with $g \in \mathcal{E}'(\mathbb{R}^n)$, (3.22) and (2.16), we find

$$f = \sum_{\lambda \in \mathcal{Z}_+(\tilde{\Omega}_{r_1})} \sum_{\mu \in \mathcal{Z}_+(\tilde{\Omega}_{r_2})} \frac{4\lambda\mu}{(\lambda^2 - \mu^2) \tilde{\Omega}'_{r_1}(\lambda) \tilde{\Omega}'_{r_2}(\mu)} (f * (\Omega_{r_2} * \Omega_{r_1}^\lambda) - f * (\Omega_{r_1} * \Omega_{r_2}^\mu)). \tag{4.3}$$

Finally, using (4.3), (2.12), and the commutativity of the convolution operator with the differentiation operator, we arrive at formula (2.20). Thus, Theorem 3 is proved. \square

5. Conclusion

The proof of Theorem 3 shows that the key role in formula (2.20) is played by the expansion of the delta function into a series of distributions Ψ_r^λ , $\lambda \in \mathcal{Z}_+(\tilde{\Omega}_r)$ (see Lemma 5). This system of distributions is biorthogonal to the system of spherical functions φ_μ , $\mu \in \mathcal{Z}_+(\tilde{\Omega}_r)$, i.e.,

$$\langle \Psi_r^\lambda, \varphi_\mu \rangle = \begin{cases} 0 & \text{if } \mu \neq \lambda, \\ 1 & \text{if } \mu = \lambda \end{cases}$$

(see (2.4), (3.15) and (3.16)). Using similar expansions, it is possible to obtain inversion formulas for other convolution operators with radial distributions.

REFERENCES

1. Berenstein C. A., Gay R., Yger A. Inversion of the local Pompeiu transform. *J. Analyse Math.*, 1990. Vol. 54, No. 1. P. 259–287. DOI: [10.1007/bf02796152](https://doi.org/10.1007/bf02796152)
2. Berenstein C. A., Struppa D. C. Complex analysis and convolution equations. In: *Encyclopaedia Math. Sci., vol. 54: Several Complex Variables V. Khenkin G.M. (ed.)*. Berlin, Heidelberg: Springer, 1993. P. 1–108. DOI: [10.1007/978-3-642-58011-6_1](https://doi.org/10.1007/978-3-642-58011-6_1)
3. Berenstein C. A., Taylor B. A., Yger A. On some explicit deconvolution formulas. *J. Optics (Paris)*, 1983. Vol. 14, No. 2. P. 75–82. DOI: [10.1088/0150-536X/14/2/003](https://doi.org/10.1088/0150-536X/14/2/003)
4. Berenstein C. A., Yger A. Le problème de la déconvolution. *J. Funct. Anal.*, 1983. Vol. 54, No. 2. P. 113–160. DOI: [10.1016/0022-1236\(83\)90051-4](https://doi.org/10.1016/0022-1236(83)90051-4) (in French)
5. Berkani M., El Harchaoui M., Gay R. Inversion de la transformation de Pompéiu locale dans l'espace hyperbolique quaternique – Cas des deux boules. *J. Complex Var., Theory Appl.*, 2000. Vol. 43, No. 1. P. 29–57. DOI: [10.1080/17476930008815300](https://doi.org/10.1080/17476930008815300) (in French)
6. Delsarte J. Note sur une propriété nouvelle des fonctions harmoniques. *C. R. Acad. Sci. Paris Sér. A–B*, 1958. Vol. 246. P. 1358–1360. URL: <https://zbmath.org/0084.09403> (in French)
7. Denmead Smith J. Harmonic analysis of scalar and vector fields in \mathbb{R}^n . *Math. Proc. Cambridge Philos. Soc.*, 1972. Vol. 72, No. 3. P. 403–416. DOI: [10.1017/S0305004100047241](https://doi.org/10.1017/S0305004100047241)
8. El Harchaoui M. Inversion de la transformation de Pompéiu locale dans les espaces hyperboliques réel et complexe (Cas de deux boules). *J. Anal. Math.*, 1995. Vol. 67, No. 1. P. 1–37. DOI: [10.1007/BF02787785](https://doi.org/10.1007/BF02787785) (in French)
9. Helgason S. *Groups and Geometric Analysis: Integral Geometry, Invariant Differential Operators, and Spherical Functions*. New York: Academic Press, 1984. 667 p.
10. Helgason S. *Geometric Analysis on Symmetric Spaces*. Rhode Island: Amer. Math. Soc. Providence, 2008. 637 p.
11. Hielscher R., Quellmalz M. Reconstructing a function on the sphere from its means along vertical slices. *Inverse Probl. Imaging*, 2016. Vol. 10, No. 3. P. 711–739. DOI: [10.3934/ipi.2016018](https://doi.org/10.3934/ipi.2016018)
12. *Higher Transcendental Functions*, vol. II. Erdélyi A. (ed.) New York: McGraw-Hill, 1953. 302 p. URL: <https://resolver.caltech.edu/CaltechAUTHORS:20140123-104529738>
13. Hörmander L. *The Analysis of Linear Partial Differential Operators*, vol. I. New York: Springer-Verlag, 2003. 440 p. DOI: [10.1007/978-3-642-61497-2](https://doi.org/10.1007/978-3-642-61497-2)
14. Il'in V. A., Sadovnichij V. A., Sendov Bl. Kh. *Matematicheskij analiz* [Mathematical Analysis], vol. II. Moscow: Yurayt-Izdat, 2013. 357 p. (in Russian).
15. Levin B. Ya. *Raspredelenie kornej celykh funkcij* [Distribution of Roots of Entire Functions]. Moscow: URSS, 2022. 632 p. (in Russian).
16. Nicolesco M. Sur un théorème de M. Pompeiu. *Bull. Sci. Acad. Royale Belgique* (5), 1930. Vol. 16. P. 817–822. (in French)
17. Pompéiu D. Sur certains systèmes d'équations linéaires et sur une propriété intégrale de fonctions de plusieurs variables. *C. R. Acad. Sci. Paris*, 1929. Vol. 188. P. 1138–1139. (in French)
18. Pompéiu D. Sur une propriété intégrale de fonctions de deux variables réelles. *Bull. Sci. Acad. Royale Belgique* (5), 1929. Vol. 15. P. 265–269. (in French)

19. Radon J. Über die Bestimmung von Funktionen durch ihre Integralwerte längs gewisser Mannigfaltigkeiten. *Ber. Verh. Sächs. Akad. Wiss. Leipzig. Math.-Nat. Kl.*, 1917. Vol. 69. P. 262–277. (in German)
20. Rubin B. Reconstruction of functions on the sphere from their integrals over hyperplane sections. *Anal. Math. Phys.*, 2019. Vol. 9, No. 4. P. 1627–1664. DOI: [10.1007/s13324-019-00290-1](https://doi.org/10.1007/s13324-019-00290-1)
21. Salman Y. Recovering functions defined on the unit sphere by integration on a special family of sub-spheres. *Anal. Math. Phys.*, 2017. Vol. 7, No. 2. P. 165–185. DOI: [10.1007/s13324-016-0135-7](https://doi.org/10.1007/s13324-016-0135-7)
22. Vladimirov V. S., Zharinov V. V. *Urvneniya Matematicheskoy Fiziki* [Equations of Mathematical Physics]. Moscow: FIZMATLIT, 2008. 400 p. (in Russian).
23. Volchkov V. V. *Integral Geometry and Convolution Equations*. Dordrecht: Kluwer Academic Publishers, 2003. 454 p. DOI: [10.1007/978-94-010-0023-9](https://doi.org/10.1007/978-94-010-0023-9)
24. Volchkov V. V., Volchkov Vit. V. Convolution equations in many-dimensional domains and on the Heisenberg reduced group. *Sb. Math.*, 2008. Vol. 199, No. 8. P. 1139–1168. DOI: [10.1070/SM2008v199n08ABEH003957](https://doi.org/10.1070/SM2008v199n08ABEH003957)
25. Volchkov V. V., Volchkov Vit. V. *Harmonic Analysis of Mean Periodic Functions on Symmetric Spaces and the Heisenberg Group*. London: Springer, 2009. 671 p. DOI: [10.1007/978-1-84882-533-8](https://doi.org/10.1007/978-1-84882-533-8)
26. Volchkov V. V., Volchkov Vit. V. Inversion of the local Pompeiu transformation on Riemannian symmetric spaces of rank one. *J. Math. Sci.*, 2011. Vol. 179, No. 2. P. 328–343. DOI: [10.1007/s10958-011-0597-y](https://doi.org/10.1007/s10958-011-0597-y)
27. Volchkov V. V., Volchkov Vit. V. *Offbeat Integral Geometry on Symmetric Spaces*. Basel: Birkhäuser, 2013. 592 p. DOI: [10.1007/978-3-0348-0572-8](https://doi.org/10.1007/978-3-0348-0572-8)
28. Volchkov V. V., Volchkov Vit. V. Spherical means on two-point homogeneous spaces and applications. *Izv. Math.*, 2013. Vol. 77, No. 2. P. 223–252. DOI: [10.1070/IM2013v077n02ABEH002634](https://doi.org/10.1070/IM2013v077n02ABEH002634)
29. Volchkov Vit. V. On functions with given spherical means on symmetric spaces. *J. Math. Sci.*, 2011. Vol. 175, No. 4. P. 402–412. DOI: [10.1007/s10958-011-0354-2](https://doi.org/10.1007/s10958-011-0354-2)
30. Volchkov Vit. V., Volchkova N. P. Inversion of the local Pompeiu transform on the quaternion hyperbolic space. *Dokl. Math.*, 2001. Vol. 64, No. 1. P. 90–93.
31. Volchkov Vit. V., Volchkova N. P. Inversion theorems for the local Pompeiu transformation in the quaternion hyperbolic space. *St. Petersburg Math. J.*, 2004. Vol. 15, No. 5. P. 753–771. DOI: [10.1090/S1061-0022-04-00830-1](https://doi.org/10.1090/S1061-0022-04-00830-1)
32. Volchkova N. P., Volchkov Vit. V. Deconvolution problem for indicators of segments. *Math. Notes NEFU*, 2019. Vol. 26, No. 3. P. 3–14. DOI: [10.25587/SVFU.2019.47.12.001](https://doi.org/10.25587/SVFU.2019.47.12.001)
33. Zalcman L. Analyticity and the Pompeiu problem. *Arch. Rational Mech. Anal.*, 1972. Vol. 47, No. 3. P. 237–254. DOI: [10.1007/BF00250628](https://doi.org/10.1007/BF00250628)
34. Zalcman L. Offbeat integral geometry. *Amer. Math. Monthly*, 1980. Vol. 87, No. 3. P. 161–175. DOI: [10.1080/00029890.1980.11994985](https://doi.org/10.1080/00029890.1980.11994985)
35. Zalcman L. A bibliographic survey of the Pompeiu problem. In: *NATO ASI Series, vol. 365: Approximation by Solutions of Partial Differential Equations, Fuglede B. et al (eds.)*. Dordrecht: Springer, 1992. Vol. 365. P. 185–194. DOI: [10.1007/978-94-011-2436-2_17](https://doi.org/10.1007/978-94-011-2436-2_17)
36. Zalcman L. Supplementary bibliography to: “A bibliographic survey of the Pompeiu problem”. In: *Contemp. Math., vol. 278: Radon Transforms and Tomography, E.T. Quinto et al. (eds.)*. Amer. Math. Soc., 2001. P. 69–74. DOI: [10.1090/conm/278](https://doi.org/10.1090/conm/278)

Editor: Tatiana F. Filippova
Managing Editor: Oxana G. Matviychuk
Design: Alexander R. Matviychuk

Contact Information

16 S. Kovalevskaya str., Ekaterinburg, Russia, 620990

Phone: +7 (343) 375-34-73

Fax: +7 (343) 374-25-81

Email: secretary@umjuran.ru

Web-site: <https://umjuran.ru>

N.N.Krasovskii Institute of Mathematics and Mechanics
of the Ural Branch of Russian Academy of Sciences

Ural Federal University named after the first President of Russia B.N.Yeltsin

Distributed for free